



SWISS  TOOLS<sup>®</sup>

*S w i s s*  
**V A R I A**  
**1905**

by **SWISS  TOOLS**

Seite / page 17

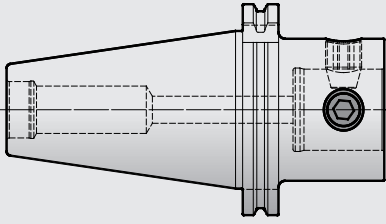

Seite / page 17

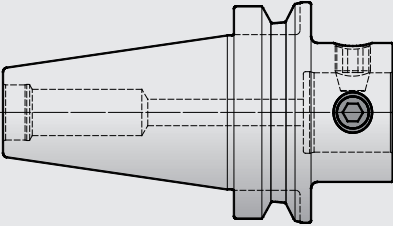

Seite / page 18

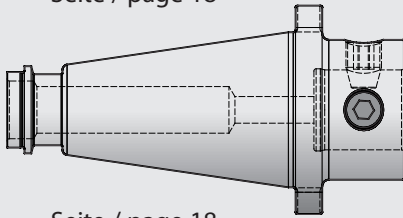

Seite / page 18

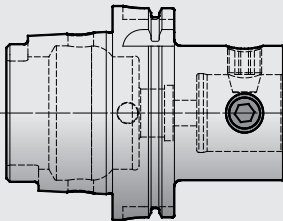

Seite / page 18

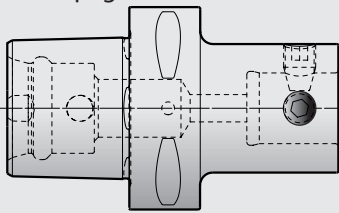

Seite / page 50

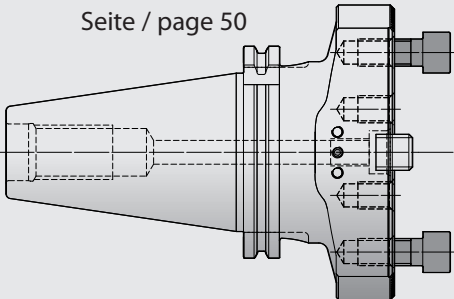

Seite / page 50

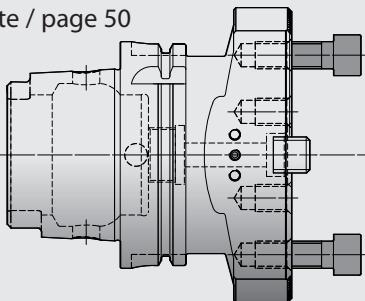

Seite / page 19

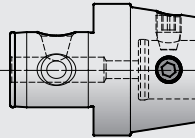

Seite / page 19

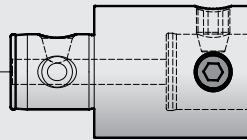

Seite / page 50

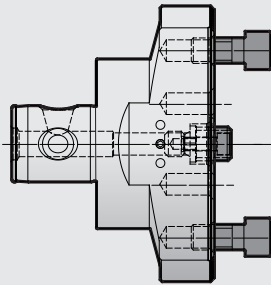

Seite / page 47

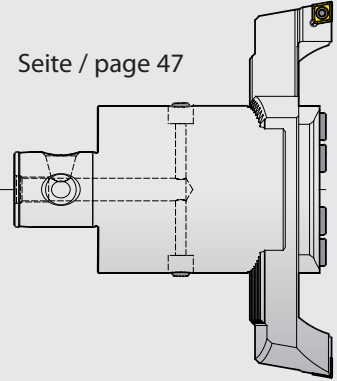

Seite / page 40-42

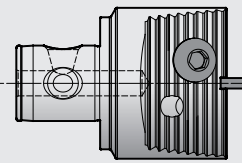

Seite / page 51

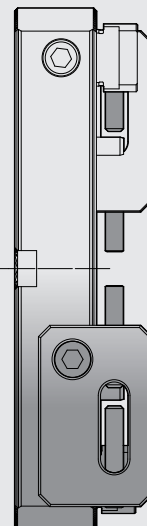

Seite / page 52

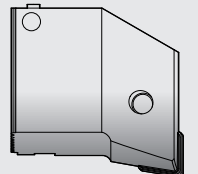
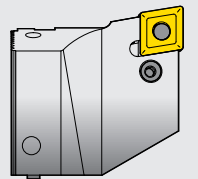

Seite / page 39

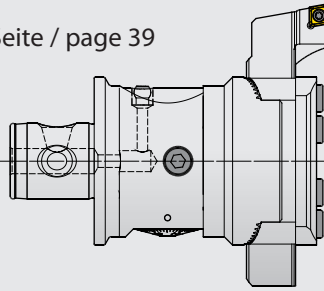

**Wendeplatten / Inserts**  
Seite / page 54+55



Seite / page 6

**NEW  
DIGITAL**

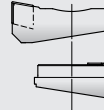

Seite / page 38

Seite / page 32-35



Seite / page 36+37

**NEW  
DIGITAL**

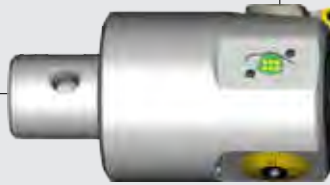

Seite / page 42+43

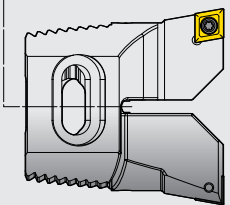
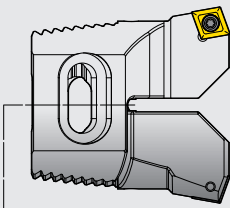

Seite / page 53



**NEW  
DIGITAL**

Seite /  
page 30



Seite / page 25

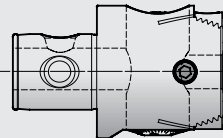

Seite / page 22+23



**NEW  
DIGITAL**

Seite / page 20+21



Seite / page 20+21

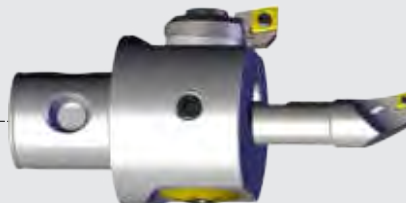

Seite / page 28

Seite / page 25

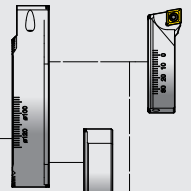

Seite / page 29



Seite / page 28

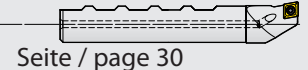

Seite / page 30

Seite / page 27



Seite / page 27

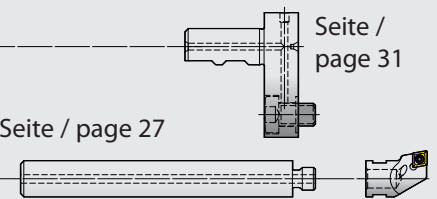

Seite /  
page 31

• Technische Hinweise siehe Betriebsan-  
leitung

• Fore more technical information see  
operating manual

# THE WORLD'S SMALLEST

digital fine boring head from  $\varnothing$  0.3 mm



# WELTNEUHEIT

kleinster digitaler Feinbohrkopf ab  $\varnothing$  0.3 mm

---

# SWISS DAMPING TECHNOLOGY

schwingungsgedämpfte Lösungen  
damped boring solutions



# PSC DIGITALE FEINBOHRWERKZEUGE DIGITAL FINE BORING HEADS

- ein Display für alle Feinbohrköpfe  
Ø 0.3 mm - 2205.0 mm
  - Anzeige umkehrbar (Links-/ Rechtshänder)
  - mm/inch umschaltbar
  - Standard AAA Batterie zur Stromversorgung
  - Display wird über Magnetkraft am Werkzeug gehalten
  - Einstellgenauigkeit 0.001mm im Durchmesser
  - direktes Wegmeßsystem (kein Umkehrspiel)
  - keine Batterie und Auswerteelektronik im Werkzeug verbaut
  - sehr einfache Bedienung
  - digital und analog einsetzbar
- one display for all fine boring heads diameter 0.3 mm – 2205 mm
  - display reversible (LH/RH)
  - mm/inch switchable
  - standard AAA battery required
  - display unit will docked with magnetic forces at the tool
  - 0.001 accuracy in diameter
  - direct measurement system (no backlash)
  - no battery and electronic evaluation unit inside the tool
  - very easy operation
  - for digital and analog use



## ECO LINE

MODULAR BORING SYSTEM Ø 9.75 - 650.1 mm  
*don't think about the interface you already have it*

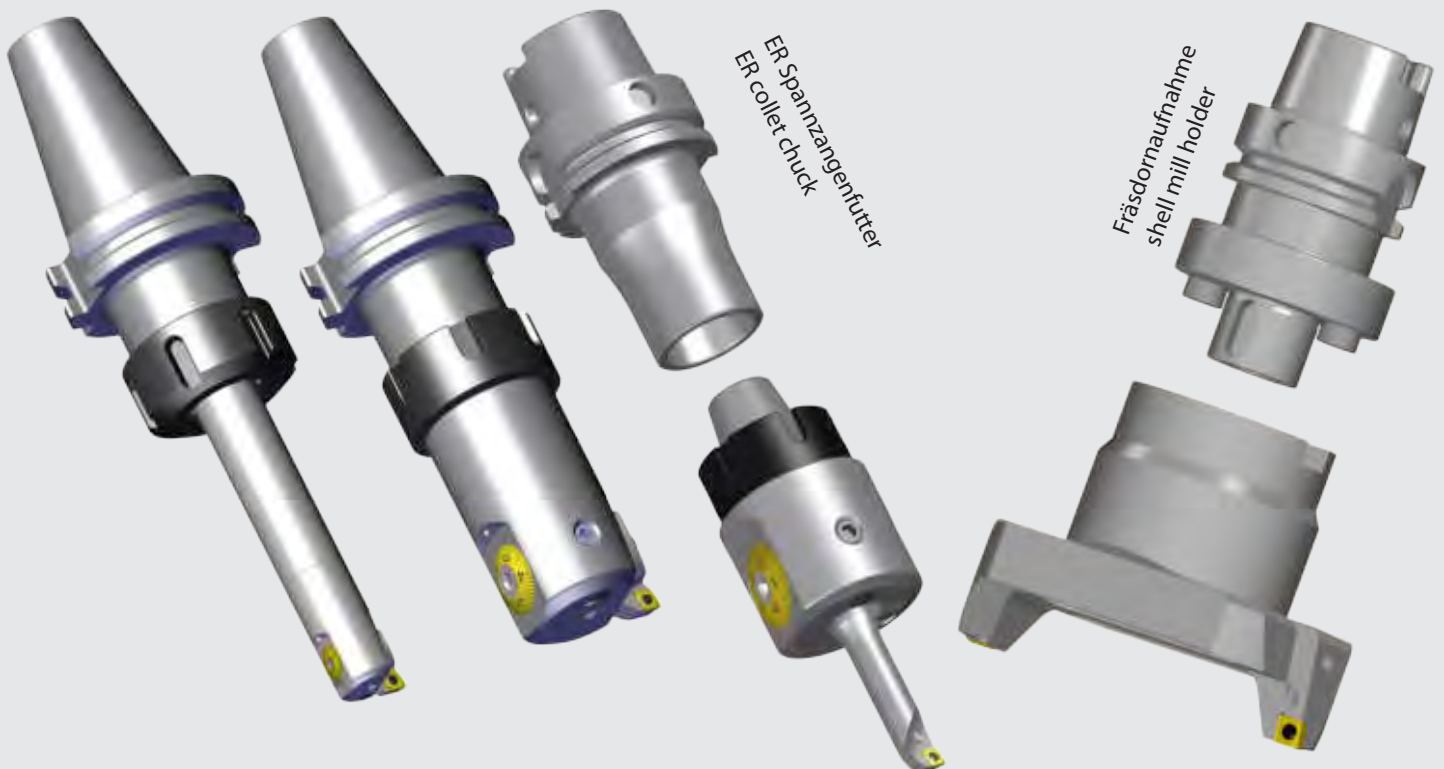

- ein Display für alle Feinbohrköpfe Ø 0,3 mm - 2205,0 mm
  - Anzeige umkehrbar (Links-/ Rechtshänder)
  - mm/inch umschaltbar
  - Standard AAA Batterie zur Stromversorgung
  - Display wird über Magnetkraft am Werkzeug gehalten
  - Einstellgenauigkeit 0.001mm im Durchmesser
  - direktes Wegmeßsystem (kein Umkehrspiel)
  - keine Batterie und Auswerteelektronik im Werkzeug verbaut
  - sehr einfache Bedienung
  - digital und analog einsetzbar
- one display for all fine boring heads diameter 0.3 mm – 2205 mm
  - display reversible (LH/RH)
  - mm/inch switchable
  - standard AAA battery required
  - display unit will docked with magnetic forces at the tool
  - 0.001 accuracy in diameter
  - direct measurement system (no backlash)
  - no battery and electronic evaluation unit inside the tool
  - very easy operation
  - for digital and analog use



Bestell-Nr. / Order number	Anzeigeeinheit/ display unit
C09.028.024.077	

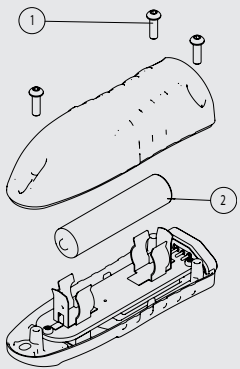

**Ersatzteile / Zubehör**

**Spare parts / Accessories**

**C09**

Für Anzeigeeinheit For display unit	Bestell-Nr. / Order number	Bestell-Nr. / Order number	Bestell-Nr. / Order number
	Torx-Schraube / Torx screw	1 Batterie / Battery	2 Torx-Schlüssel / Torx driver
C09.028.024.077	J00.309.022.008	J00.308.011.045	J00.254.006.000



Ø 150,0 mm - 2205,0 mm Seite / page 47



Ø 3,0 mm - 88,1 mm Seite / page 22



Ø 23,9 mm - 203,1 mm Seite / page 32

**NEW**

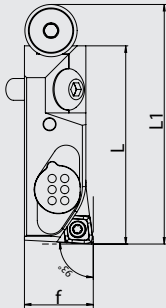
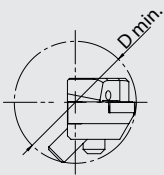

- Einfaches Handling
- Präzise Masskorrektur
- Direktes Weg-Messsystem
- Wartungsfrei

- Easy handling
- Precise adjustment
- No backlash
- Maintenance-free

Bestell-Nr. / Order number	f	Ø D min.	L	L	Wendeplatte / Insert
KKH.WCA.016.045	16	25	45	55	CC.. 06 02 ..

- Feinverstellung digitale Anzeige 0.001mm
- Radialer Verstellweg: min. 0,4 mm
- Axiale Längenverstellung: 1.5 mm über Keilelement
- Drehzahl: max.10.000 U/min
- Innenkühlung direkt auf die Werkzeugschneide

- Fine adjustment digital display 0.001mm
- Radial adjustment: min. 0.4 mm
- Axial length adjustment: 1.5 mm
- Speed: max.10.000 rpm
- Internal cooling directly on the tool cutting edge

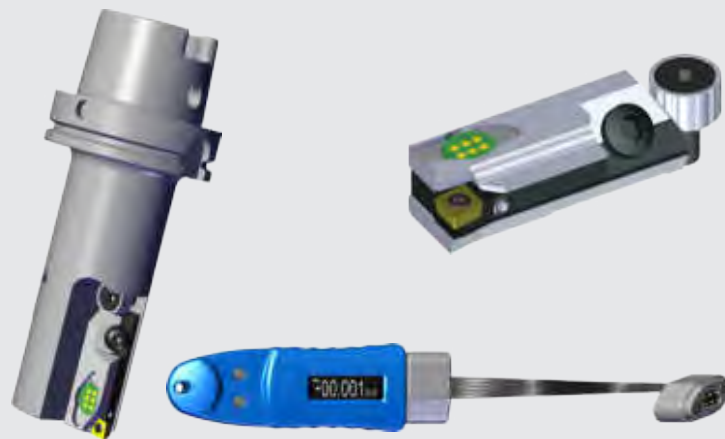

**Anzeigeeinheit für  
Feinbohr-Kurzklemmhalter**

**Display unit for  
fine boring module**

**GH1**

Bestell-Nr. / Order number	Anzeigeeinheit/ display unit
GH1.DA2.BGK.077	



- Anzeige umkehrbar (Links-/ Rechtshänder)
- mm/inch umschaltbar
- Standard AAA Batterie zur Stromversorgung
- Display wird über Magnetkraft am Werkzeug gehalten
- Einstellgenauigkeit 0.001mm im Durchmesser
- direktes Wegmeßsystem (kein Umkehrspiel)
- keine Batterie und Auswerteelektronik im Werkzeug verbaut
- sehr einfache Bedienung
- digital und analog einsetzbar

- display reversible (LH/RH)
- mm/inch switchable
- standard AAA battery required
- display unit will docked with magnetic forces at the tool
- 0.001 accuracy in diameter
- direct measurement system (no backlash)
- no battery and electronic evaluation unit inside the tool
- very easy operation
- for digital and analog use

# ECO LINE

MODULAR BORING SYSTEM Ø 9.75 mm - 650.1 mm

*don't think about the interface you already have it*

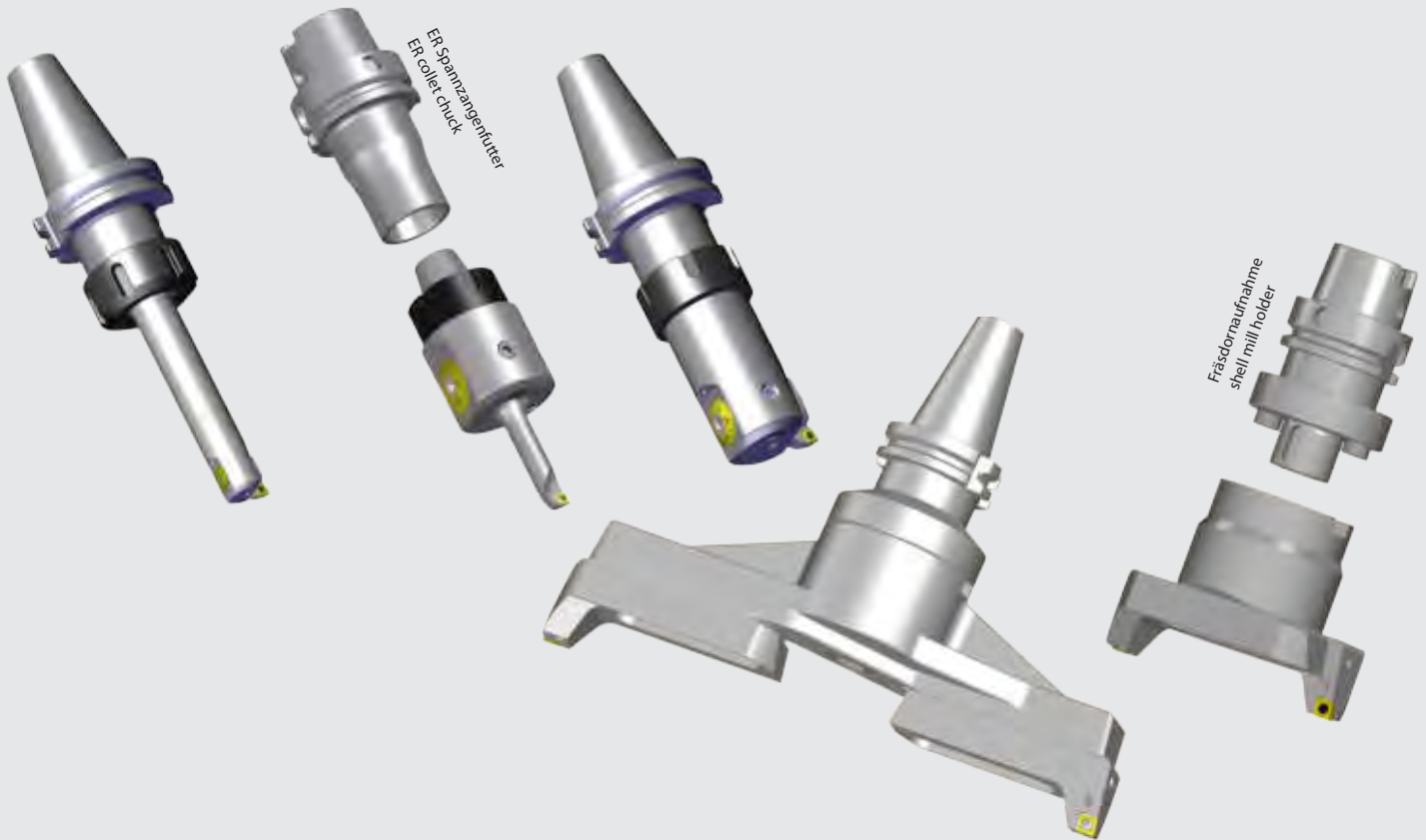

SMART-HEAD

## Ausdrehset Ø9.75-30.1

## Fine boring set Ø9.75-30.1

- erweiterbar von Ø3 bis Ø88.1
- Schnittstelle ER32 DIN6499

- can be upgraded from Ø3 up to Ø88.1
- connection ER32 DIN 6499

Bestell-Nr. / Order number	Ø D/ System	Ø A min.	Ø A max.	L	Ausdrehkopf / Fine boring head
<b>SMART ER32</b>					
G85.032.010.030	55 / ER32	9.75	30.1	60	B11.032.055.060

- Werkzeug in einem Spannzangenfutter spannen.

- Clamp tool in a collet chuck.

### Inhalt

### Content

1 Koffer / Case					
1 Ausdrehkopf / Fine boring head					B11.032.055.060
1 Ausdrehstahl / Boring bar			Ø9.75-15.1		B54.010.006.075
1 Ausdrehstahl / Boring bar			Ø14.75-20.1		B54.015.006.090
1 Ausdrehstahl / Boring bar			Ø19.75-25.1		B54.020.006.105
1 Ausdrehstahl / Boring bar			Ø24.75-30.1		B54.025.006.115
1 Inbusschlüssel / Allen wrench			SW5		
1 Torx-Schlüssel / Torx driver			T7		

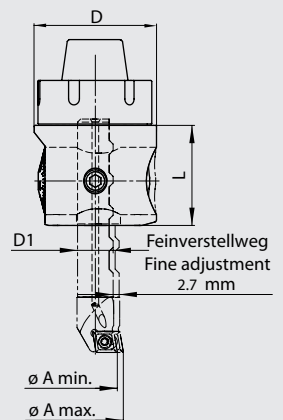



## Feinbohrköpfe Ø23.9-87.1

## Fine boring heads Ø23.9-87.1



- DurchmesserEinstellung mit geringstem Umkehrspiel
- Zustellgenauigkeit von 0.01mm resp. über Nonius 0.002mm im Durchmesser
- mit Innenkühlung

- diameter setting with minimal reversal backlash
- 0.01mm diametrical adjustment resp. 0.002mm by nonius
- with inner coolant supply

Bestell-Nr. / Order number	Ø D/ System	Ø A min.	Ø A max.	L	Wendeplattenhalter / Insert holder
U20_F20.K21.150	20	23.9	31.1	150	C14.011.024.006 (CC.. 06 02 ..)
U25_F25.K21.170	25	30.9	40.1	170	C14.013.031.006 (CC.. 06 02 ..)

- Werkzeug in einem Spannzangen- oder Hydrodehnfutter spannen.
- **inklusive Wendeplattenhalter**

- Clamp tool in a collet or hydraulic chuck.
- **insert holder included**

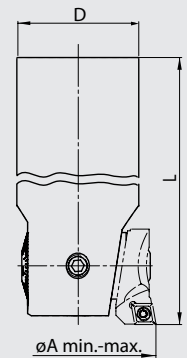

Bestell-Nr. / Order number	Ø D/ System	Ø A min.	Ø A max.	L	Wendeplattenhalter / Insert holder
E25_F32.K21.065	32 / ER25	39.9	51.1	65	C14.017.040.006 (CC.. 06 02 ..)
E32_F42.K21.075	42 / ER32	50.9	67.1	75	C14.022.051.006 (CC.. 06 02 ..)
E40_F55.K21.085	55 / ER40	66.9	87.1	85	C14.030.067.009 (CC.. 09 T3 ..)

- Werkzeug in einem Spannzangenfutter spannen.
- **inklusive Wendeplattenhalter**

- Clamp tool in a collet chuck.
- **insert holder included**

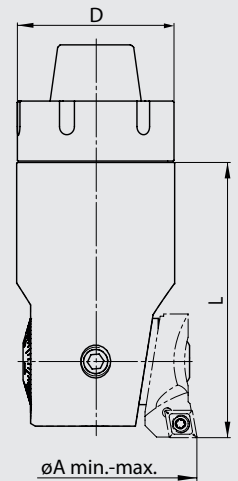

## Zweischneiderköpfe Ø23.5-87.1

## Twin cutter boring heads Ø23.5-87.1



- mit Innenkühlung

- with inner coolant supply

Bestell-Nr. / Order number	Ø D/ System	Ø A min.	Ø A max.	L	Wendeplattenhalter / Insert holder
U20_Z20.K23.150	20	23.5	31.1	150	D14.020.024.006 (CC.. 06 02 ..)
U25_Z25.K23.170	25	29.5	40.1	170	D14.025.031.006 (CC.. 06 02 ..)

- Werkzeug in einem Spannzangen- oder Hydrodehnfutter spannen.
- **inklusive Wendeplattenhalter**

- Clamp tool in a collet or hydraulic chuck.
- **insert holder included**

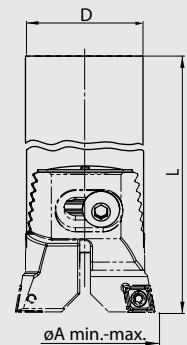

Bestell-Nr. / Order number	Ø D/ System	Ø A min.	Ø A max.	L	Wendeplattenhalter / Insert holder
E25_Z32.K23.065	32 / ER25	39.5	51.1	65	D14.032.040.009 (CC.. 09 T3 ..)
E32_Z42.K23.075	42 / ER32	49.5	67.1	75	D14.039.051.009 (CC.. 09 T3 ..)
E40_Z55.K23.085	55 / ER40	65.5	87.1	85	D14.050.067.012 (CC.. 12 04 ..)

- Werkzeug in einem Spannzangenfutter spannen.
- **inklusive Wendeplattenhalter**

- Clamp tool in a collet chuck.
- **insert holder included**

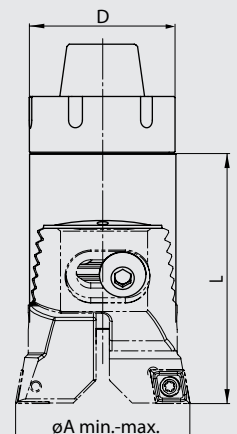

**Ausdrehset ø9.75-30.1**

**Fine boring set ø9.75-30.1**

• erweiterbar von ø3 bis ø88.1

• can be upgraded from ø3 up to ø88.1



Bestell-Nr. / Order number	D	ø A min.	ø A max.	L	L1	Ausdrehkopf / Fine boring head
<b>WH6 modular</b>						
G85.063.010.030	63	9.75	30.1	50	-	B04.063.025.050
<b>DIN 69893 HSK 63 A</b>						
G85.163.010.030	55	9.75	30.1	95	70	B08.806.055.095
<b>DIN 69871 AD 40</b>						
G85.415.010.030	55	9.75	30.1	90	80	B08.440.055.090
<b>MAS BT 40</b>						
G86.412.010.030	55	9.75	30.1	90	80	B08.540.055.090

Inhalt	Content	
1 Koffer / Case		
1 Ausdrehkopf / Fine boring head		
1 Ausdrehstahl / Boring bar	ø9.75-15.1	B54.010.006.075
1 Ausdrehstahl / Boring bar	ø14.75-20.1	B54.015.006.090
1 Ausdrehstahl / Boring bar	ø19.75-25.1	B54.020.006.105
1 Ausdrehstahl / Boring bar	ø24.75-30.1	B54.025.006.115
1 Inbusschlüssel / Allen wrench	SW5	
1 Torx-Schlüssel / Torx driver	T7	

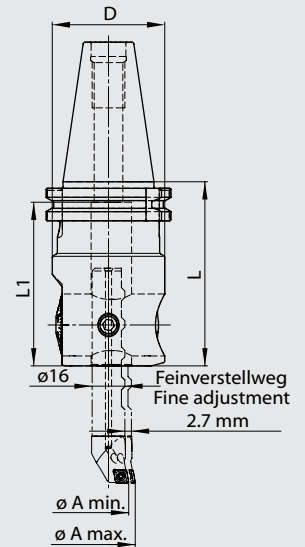
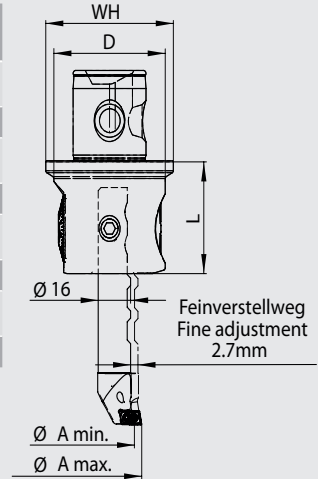

**Ausdrehset ø9.75-30.1 DIGITAL**

**Fine boring set ø9.75-30.1 DIGITAL**

• erweiterbar von ø3 bis ø88.1

• can be upgraded from ø3 up to ø88.1

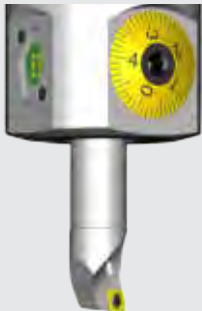

Bestell-Nr. / Order number	D	ø A min.	ø A max.	L	L1	Ausdrehkopf / Fine boring head
<b>WH6 modular</b>						
G89.063.010.030	55	9.75	30.1	45	75	B06.063.025.050
<b>DIN 69893 HSK 63 A</b>						
G89.163.010.030	55	9.75	30.1	95	70	B09.806.055.095
<b>DIN 69871 AD 40</b>						
G89.415.010.030	55	9.75	30.1	90	80	B09.440.055.090
<b>MAS BT 40</b>						
G89.412.010.030	55	9.75	30.1	90	80	B09.540.055.090

Inhalt	Content	
1 Koffer / Case		
1 Ausdrehkopf / Fine boring head		
1 Ausdrehstahl / Boring bar	ø9.75-15.1	B54.010.006.075
1 Ausdrehstahl / Boring bar	ø14.75-20.1	B54.015.006.090
1 Ausdrehstahl / Boring bar	ø19.75-25.1	B54.020.006.105
1 Ausdrehstahl / Boring bar	ø24.75-30.1	B54.025.006.115
1 Inbusschlüssel / Allen wrench	SW5	
1 Torx-Schlüssel / Torx driver	T7	
1 Digitale Anzeigeeinheit / dig. display	C09.028.024.077	

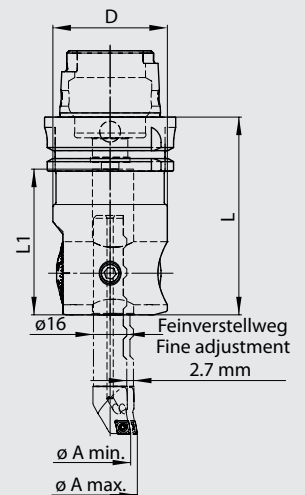

• erweiterbar von ø3 bis ø88.1

• can be upgraded from ø3 up to ø88.1

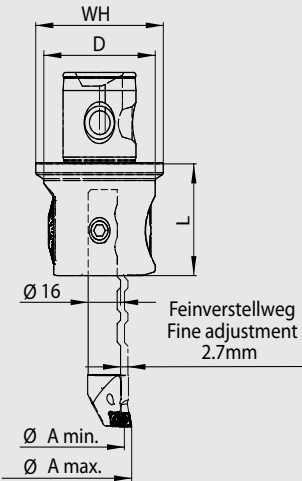

Bestell-Nr. / Order number	D	ø A min.	ø A max.	L	L1	Ausdrehkopf / Fine boring head
<b>WH6 modular</b>						
G86.063.010.088	55	9.75	88.1	50	-	B04.063.025.050
<b>DIN 69893 HSK 63 A</b>						
G85.163.010.088	55	9.75	88.1	95	70	B08.806.055.095
<b>DIN 69871 AD 40</b>						
G85.415.010.088	55	9.75	88.1	90	80	B08.440.055.090
<b>MAS BT 40</b>						
G86.412.010.088	55	9.75	88.1	90	80	B08.540.055.090



Inhalt	Content	
1 Koffer / Case		
1 Ausdrehkopf / Fine boring head		
1 Ausdrehstahl / Boring bar	ø9.75-15.1	B54.010.006.075
1 Ausdrehstahl / Boring bar	ø14.75-20.1	B54.015.006.090
1 Ausdrehstahl / Boring bar	ø19.75-25.1	B54.020.006.105
1 Ausdrehstahl / Boring bar	ø24.75-30.1	B54.025.006.115
1 Schaft / shank	ø29.75-48.1	B56.030.048.115
1 Schaft / shank	ø47.75-88.1	B56.048.088.115
1 Wendeplattenhalter / Insert holder	ø29.75-48.1	B56.030.006.012
1 Wendeplattenhalter / Insert holder	ø47.75-88.1	B56.048.006.014
1 Inbusschlüssel / Allen wrench	SW4	
1 Inbusschlüssel / Allen wrench	SW5	
1 Torx-Schlüssel / Torx driver	T7	

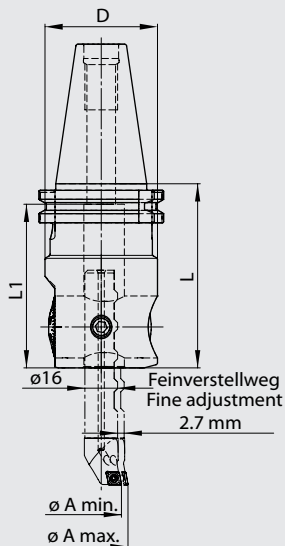

**Ausdrehset ø9.75-88.1  
DIGITAL**

**Fine boring set ø9.75-88.1  
DIGITAL**

• erweiterbar von ø3 bis ø88.1

• can be upgraded from ø3 up to ø88.1

Bestell-Nr. / Order number	D	ø A min.	ø A max.	L	L1	Ausdrehkopf / Fine boring head
<b>WH6 modular</b>						
G89.063.010.088	55	9.75	88.1	50	-	B06.063.025.050
<b>DIN 69893 HSK 63 A</b>						
G89.163.010.088	55	9.75	88.1	95	70	B09.806.055.095
<b>DIN 69871 AD 40</b>						
G89.415.010.088	55	9.75	88.1	90	80	B09.440.055.090
<b>MAS BT 40</b>						
G89.412.010.088	55	9.75	88.1	90	80	B09.540.055.090



Inhalt	Content	
1 Koffer / Case		
1 Ausdrehkopf / Fine boring head		
1 Ausdrehstahl / Boring bar	ø9.75-15.1	B54.010.006.075
1 Ausdrehstahl / Boring bar	ø14.75-20.1	B54.015.006.090
1 Ausdrehstahl / Boring bar	ø19.75-25.1	B54.020.006.105
1 Ausdrehstahl / Boring bar	ø24.75-30.1	B54.025.006.115
1 Schaft / shank	ø29.75-48.1	B56.030.048.115
1 Schaft / shank	ø47.75-88.1	B56.048.088.115
1 Wendeplattenhalter / Insert holder	ø29.75-48.1	B56.030.006.012
1 Wendeplattenhalter / Insert holder	ø47.75-88.1	B56.048.006.014
1 Inbusschlüssel / Allen wrench	SW4	
1 Inbusschlüssel / Allen wrench	SW5	
1 Torx-Schlüssel / Torx driver	T7	
1 Digitale Anzeigeeinheit / dig. display	C09.028.024.077	

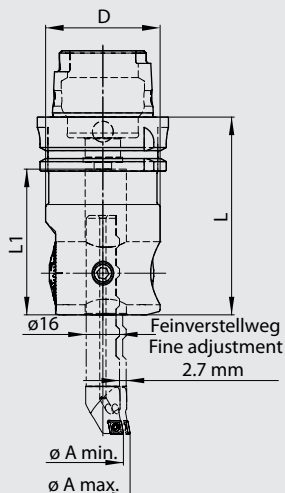
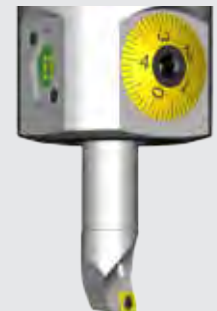

Ausdrehset  $\varnothing 9.75-164$ Fine boring set  $\varnothing 9.75-164$ • erweiterbar von  $\varnothing 3$  bis  $\varnothing 320$ • can be upgraded from  $\varnothing 3$  up to  $\varnothing 320$ 

## WH6

Bestell-Nr. / Order number	WH	L	L2	$\varnothing A$ min.	$\varnothing A$ max.	Ausdrehkopf / Fine boring head
G88.063.010.164	WH6	60	89	9.75	164	B10.063.025.060

## WH6

## DIN 69871 AD 40

Bestell-Nr. / Order number	ISO	A	L1	L2	$\varnothing A$ min.	$\varnothing A$ max.	Ausdrehkopf / Fine boring head
G88.415.010.164	40	91	81	120	9.75	164	B10.440.063.090

## DIN 69871 AD 40

## MAS BT 40

Bestell-Nr. / Order number	BT	A	L1	L2	$\varnothing A$ min.	$\varnothing A$ max.	Ausdrehkopf / Fine boring head
G88.412.010.164	40	91	81	120	9.75	164	B10.540.063.090

## MAS BT 40

## DIN 69893 HSK A 63

Bestell-Nr. / Order number	HSK	A	L1	L2	$\varnothing A$ min.	$\varnothing A$ max.	Ausdrehkopf / Fine boring head
G88.163.010.164	63	96	72	125	9.75	164	B10.806.063.095

## DIN 69893 HSK A 63

Inhalt	Content	
1 Koffer / Case		
1 Ausdrehkopf / Fine boring head		
1 Ausdrehstahl / Boring bar	$\varnothing 9.75-15.1$	B54.010.006.075
1 Ausdrehstahl / Boring bar	$\varnothing 14.75-20.1$	B54.015.006.090
1 Ausdrehstahl / Boring bar	$\varnothing 19.75-25.1$	B54.020.006.105
1 Ausdrehstahl / Boring bar	$\varnothing 24.75-30.1$	B54.025.006.115
1 Schaft / shank	$\varnothing 29.75-48.1$	B56.030.048.115
1 Schaft / shank	$\varnothing 47.75-88.1$	B56.048.088.115
1 Brücke / Bridge	$\varnothing 80$	B12.086.164.080
1 Wendeplattenhalter / Insert holder	$\varnothing 29.75-48.1$	B56.030.006.012
1 Wendeplattenhalter / Insert holder	$\varnothing 47.75-88.1$	B56.048.006.014
1 Inbusschlüssel / Allen wrench	SW4	
1 Inbusschlüssel / Allen wrench	SW5	
1 Torx-Schlüssel / Torx driver	T7	

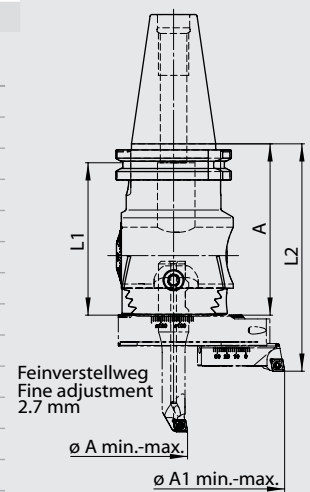
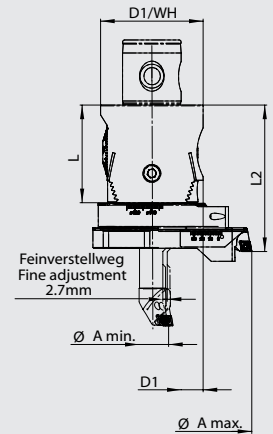

**Ausdrehset ø9.75-101.1**

**Fine boring set ø9.75-101.1**

- Zustellgenauigkeit 0.01mm resp. über Nonius 0.002mm im Durchmesser
- erweiterbar von ø3 bis ø152.1

- 0.01mm diametrical adjustment resp. 0.002mm by nonius
- can be upgraded from ø3 up to ø152.1

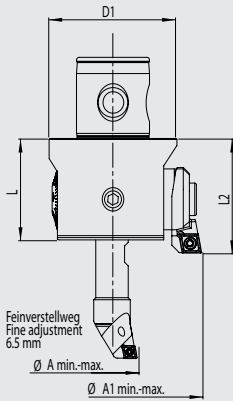

Bestell-Nr. / Order number	D1	L	L2	ø A min.	ø A max.	Ausdrehkopf / Fine boring head
G83.063.010.101	63	50.5	57	9.75	101.1	B05.063.025.050

Inhalt	Content		
1 Koffer / Case			
1 Ausdrehkopf / Fine boring head	WH6		B05.063.025.050
1 Ausdrehstahl / Boring Bar	ø 9.75 - 20.1		B54.010.006.075
1 Ausdrehstahl / Boring Bar	ø 19.75 - 30.1		B54.020.006.105
1 Schaft / Shank	ø 29.75 - 48.1		B56.030.048.115
1 Schaft / Shank	ø 47.75 - 88.1		B56.048.088.115
1 Wendeplattenhalter / Insert holder	ø 29.75 - 48.1		B56.030.006.012
1 Wendeplattenhalter / Insert holder	ø 47.75 - 88.1		B56.048.006.014
1 Wendeplattenhalter / Insert holder CC . . 09 T3 . .	ø 87.75 - 101.1 (Ø114.1)		C14.726.001.009
1 Kühlmittleinsatz / Coolant plug			J00.805.000.032
2 Torx-Schlüssel / Torx driver	T7 / T15		J00.254.007.000 J00.254.009.000
1 Inbusschlüsselset / Allen wrench set	SW 1.5 - 8		J00.892.015.080

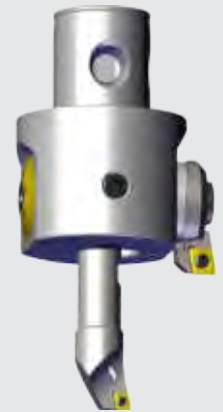

Zubehör	Accessories	
Wendeplattenhalter / Insert holder CC . . 09 T3 . .	ø 105.75 - 119.0 (ø 132.0)	C14.726.002.009
Wendeplattenhalter / Insert holder CC . . 09 T3 . .	ø 125.75 - 139.0 (ø 152.0)	C14.726.003.009
Distanzstück / Adapter F = 6.5 mm	ø 114.0 / ø 132.0 / ø 152.0	J00.803.001.006

**Ausdrehset ø86-302**

**Fine boring set ø86-302**

- erweiterbar bis ø402

- can be upgraded up to ø402

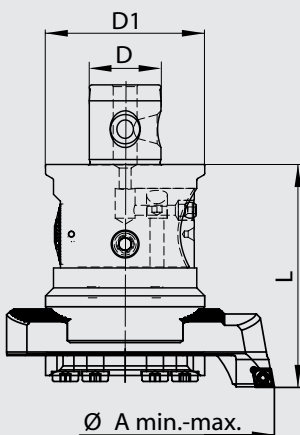

Bestell-Nr. / Order number	WH	D	D1	ø A min.	ø A max.	Feinbohrkopf / Fine boring head
G90.080.086.302	WH6/8	36	80	86	302	C44.080.086.112

Inhalt	Content	
1 Koffer / Case		
1 Feinbohrkopf / Fine boring head		C44.080.086.112
1 Wendeplattenhalter / Insert holder	ø86-138	J00.354.086.009
1 Wendeplattenhalter / Insert holder	ø136-220	J00.354.136.009
1 Wendeplattenhalter / Insert holder	ø188-302	J00.354.188.009
1 Abstützung / Support block		J00.354.020.086
1 Abstützung / Support block		J00.354.020.136
1 Druckplatte / Clamp plate		J00.354.010.086
1 Druckplatte / Clamp plate		J00.354.010.136
10 Wendeplatten / Inserts	CC . . 09 T3 . .	H00.600.200.094
1 Inbusschlüssel / Allen wrench	SW5	
1 Torx-Schlüssel / Torx driver	T15	



Ausdrehset  $\varnothing$ 39.9-70.1Fine boring set  $\varnothing$ 39.9-70.1

- Schnittstelle ER25 DIN6499
- Zustellgenauigkeit 0.01mm im Durchmesser
- für Wendepplatten CC . . 06 02 . .
- erweiterbar bis  $\varnothing$ 100.1

- connection ER25 DIN 6499
- 0.01mm diametrical adjustment
- for inserts CC . . 06 02 . .
- can be upgraded to  $\varnothing$ 100.1

Bestell-Nr. / Order number	D	L	L1	L2	$\varnothing$ A min.	$\varnothing$ A max.	Ausdrehkopf / Fine boring head
G84.001.040.070	39	25.5	8	20.5	39.9	70.1	E98.040.070.009

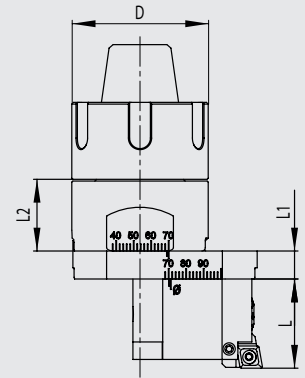

Inhalt	Content	
1 Grundkörper / Base unit	ER25	G26.025.000.000
1 Feinbohrkopf / Fine boring head	$\varnothing$ 39.9 - 70.1	E98.040.070.009
4 Schraube / Screw	M4 x 25	J00.726.004.025
1 Torxschlüssel / Torx wrench	T7	J00.254.007.000
1 Inbusschlüsselset / Allen key set	1.5-8.0	J00.892.015.080

Zubehör	Accessories	
Erweiterung / Extension	$\varnothing$ 69.9 - 100.1	B15.070.100.000

## Ersatzteile / Zubehör

## Spare parts / Accessories

G84

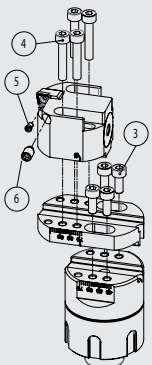

Für Feinbohrkopf	Bestell-Nr. / Order number	Bestell-Nr. / Order number	Bestell-Nr. / Order number	Bestell-Nr. / Order number
For fine boring head	Schraube / Screw (3)	Schraube / Screw (4)	Torx-Schraube / Torx-Screw (5)	Klemmschraube / Clamping screw (6)
E98.040.070.009	J00.726.004.010	J00.726.004.025	J00.254.025.006	J00.598.005.008

**Ausdrehset ø9.75-101.1**

**Fine boring set ø9.75-101.1**

- Schnittstelle ER40 DIN6499
- Zustellgenauigkeit 0.01mm resp. über Nonius 0.002mm im Durchmesser
- erweiterbar von ø3 bis ø152.1

- connection ER40 DIN 6499
- 0.01mm diametrical adjustment resp. 0.002mm by nonius
- can be upgraded from ø3 up to ø152.1

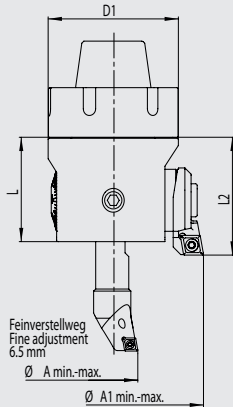

Bestell-Nr. / Order number	D1	L	L2	ø A min.	ø A max.	Ausdrehkopf / Fine boring head
G83.001.010.101	63	50.5	57	9.75	101.1	B05.040.003.152

Inhalt	Content	
1 Koffer / Case		
1 Ausdrehkopf / Fine boring head	ER40	B05.040.003.152
1 Ausdrehstahl / Boring Bar	ø 9.75 - 20.1	B54.010.006.075
1 Ausdrehstahl / Boring Bar	ø 19.75 - 30.1	B54.020.006.105
1 Schaft / Shank	ø 29.75 - 48.1	B56.030.048.115
1 Schaft / Shank	ø 47.75 - 88.1	B56.048.088.115
1 Wendeplattenhalter / Insert holder	ø 29.75 - 48.1	B56.030.006.012
1 Wendeplattenhalter / Insert holder	ø 47.75 - 88.1	B56.048.006.014
1 Wendeplattenhalter / Insert holder CC . . 09 T3 . .	ø 87.75 - 101.1 (Ø114.1)	C14.726.001.009
1 Kühlmittleinsatz / Coolant plug		J00.805.000.032
2 Torx-Schlüssel / Torx driver	T7 / T15	J00.254.007.000 J00.254.009.000
1 Inbusschlüsselset / Allen wrench set	SW 1.5 - 8	J00.892.015.080

Zubehör	Accessories	
Wendeplattenhalter / Insert holder CC . . 09 T3 . .	ø 105.75 - 119.0 (ø 132.0)	C14.726.002.009
Wendeplattenhalter / Insert holder CC . . 09 T3 . .	ø 125.75 - 139.0 (ø 152.0)	C14.726.003.009
Distanzstück / Adapter F = 6.5 mm	ø 114.0 / ø 132.0 / ø 152.0	J00.803.001.006



**Ausdrehset ø9.75-30.1**

**Fine boring set ø9.75-30.1**

- erweiterbar von ø3 bis ø88.1
- Schnittstelle ER32 DIN6499

- can be upgraded from ø3 up to ø88.1
- connection ER32 DIN 6499

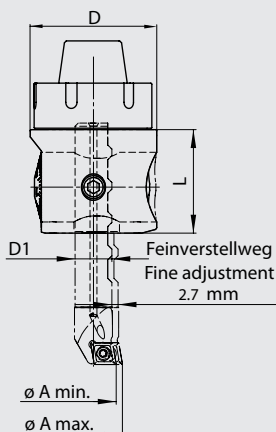

Bestell-Nr. / Order number	D	ø A min.	ø A max.	L	Ausdrehkopf / Fine boring head
<b>SMART ER32</b>					
G85.032.010.030	55	9.75	30.1	60	B11.032.055.060

Inhalt	Content	
1 Koffer / Case		
1 Ausdrehkopf / Fine boring head		B11.032.055.060
1 Ausdrehstahl / Boring bar	ø9.75-15.1	B54.010.006.075
1 Ausdrehstahl / Boring bar	ø14.75-20.1	B54.015.006.090
1 Ausdrehstahl / Boring bar	ø19.75-25.1	B54.020.006.105
1 Ausdrehstahl / Boring bar	ø24.75-30.1	B54.025.006.115
1 Inbusschlüssel / Allen wrench	SW5	
1 Torx-Schlüssel / Torx driver	T7	



Durch die seitlichen Spannschrauben (3) wird der Zapfen (2) in die Aufnahme (1) gezogen. Dank grosser Auflageflächen und hoher Vorspannung wird eine sehr grosse Steifigkeit erzielt.

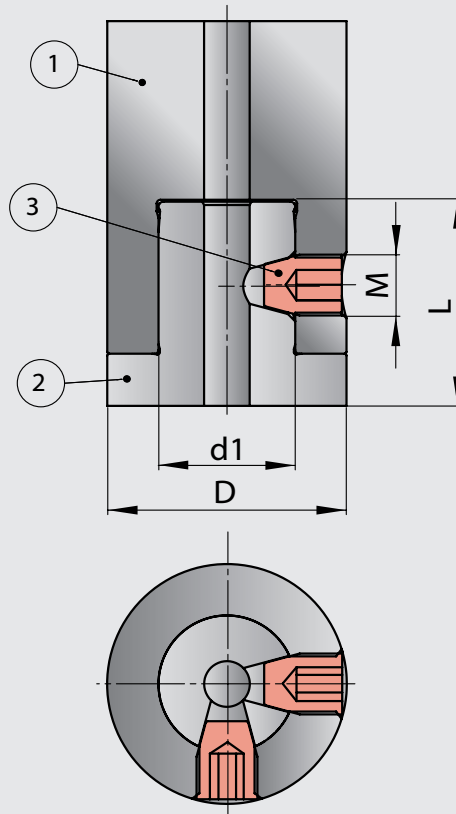

The male pilot (2) will be clamped into the female receptacle (1) by using radial clamping screws (3). A very high rigidity is achieved by a big contact surface and high prestress.

Während die Dimensionen WH1 und WH2 jeweils nur eine Spannschraube aufweisen, kommen ab WH3 zwei um 90° versetzte Spannschrauben zum Einsatz.

Meanwhile dimensions WH1 and WH2 are each containing just one clamping screw, WH3 and following dimensions are featuring two of these, shifted at 90°.

Dimensionen		Dimensions			③
WH	D	d1	L	M	Anzugsdrehmoment / Torque
WH1	20	11	13	M5x0.5	3.5Nm
WH2	25	14	18	M8x1	12Nm
WH3	32	18	22	M8x1	12Nm
WH4	40	22	28	M10x1	22Nm
WH5	50	28	28	M12x1	25Nm
WH6	63	36	40	M16x1.5	30Nm
WH8	80	36	40	M16x1.5	30Nm



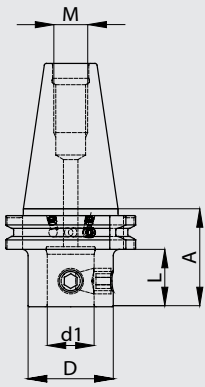

Bestell-Nr. / Order number	ISO	WH	D	d1	A	L	M
A14.430.050.048	30	WH5	50	28	48	28.9	M12
A14.440.020.046	40	WH1	20	11	46	26.9	M16
A14.440.020.085	40	WH1	20	11	85	65.9	M16
A14.440.025.046	40	WH2	25	14	46	26.9	M16
A14.440.025.085	40	WH2	25	14	85	65.9	M16
A14.440.025.120	40	WH2	25	14	120	100.9	M16
A14.440.032.046	40	WH3	32	18	46	26.9	M16
A14.440.032.085	40	WH3	32	18	85	65.9	M16
A14.440.032.120	40	WH3	32	18	120	100.9	M16
A14.440.040.046	40	WH4	40	22	46	26.9	M16
A14.440.040.100	40	WH4	40	22	100	80.9	M16
A14.440.050.046	40	WH5	50	28	46	26.9	M16
A14.440.050.100	40	WH5	50	28	100	80.9	M16
A14.440.063.066	40	WH6	63	36	66	46.9	M16
A14.450.025.085	50	WH2	25	14	85	65.9	M24
A14.450.032.046	50	WH3	32	18	46	26.9	M24
A14.450.032.100	50	WH3	32	18	100	80.9	M24
A14.450.040.046	50	WH4	40	22	46	26.9	M24
A14.450.040.100	50	WH4	40	22	100	80.9	M24
A14.450.050.046	50	WH5	50	28	46	26.9	M24
A14.450.050.085	50	WH5	50	28	85	65.9	M24
A14.450.050.120	50	WH5	50	28	120	100.9	M24
A14.450.063.066	50	WH6	63	36	66	46.9	M24
A14.450.063.100	50	WH6	63	36	100	80.9	M24
A14.450.080.046	50	WH8	80	36	46	26.9	M24
A14.450.080.085	50	WH8	80	36	85	65.9	M24

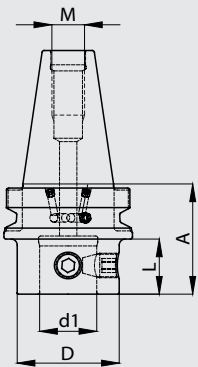

Bestell-Nr. / Order number	BT	WH	D	d1	A	L	M
A34.530.050.049	30	WH5	50	28	49	27	M12
A34.540.020.054	40	WH1	20	11	54	27	M16
A34.540.020.093	40	WH1	20	11	93	66	M16
A34.540.025.054	40	WH2	25	14	54	27	M16
A34.540.025.093	40	WH2	25	14	93	66	M16
A34.540.025.127	40	WH2	25	14	127	100	M16
A34.540.032.054	40	WH3	32	18	54	27	M16
A34.540.032.093	40	WH3	32	18	93	66	M16
A34.540.032.127	40	WH3	32	18	127	100	M16
A34.540.040.054	40	WH4	40	22	54	27	M16
A34.540.040.107	40	WH4	40	22	107	80	M16
A34.540.050.054	40	WH5	50	28	54	27	M16
A34.540.050.107	40	WH5	50	28	107	80	M16
A34.540.063.064	40	WH6	63	36	64	37	M16
A34.550.025.104	50	WH2	25	14	104	66	M24
A34.550.032.065	50	WH3	32	18	65	27	M24
A34.550.032.118	50	WH3	32	18	118	80	M24
A34.550.040.065	50	WH4	40	22	65	27	M24
A34.550.040.118	50	WH4	40	22	118	80	M24
A34.550.050.065	50	WH5	50	28	65	27	M24
A34.550.050.104	50	WH5	50	28	104	66	M24
A34.550.050.138	50	WH5	50	28	138	100	M24
A34.550.063.075	50	WH6	63	36	75	37	M24
A34.550.063.104	50	WH6	63	36	104	66	M24
A34.550.080.075	50	WH8	80	36	75	37	M24
A34.550.080.104	50	WH8	80	36	104	66	M24





Bestell-Nr. / Order number	HSK A	WH	D	d1	A	L
A44.806.020.042	63	WH1	20	11	42	16
A44.806.020.086	63	WH1	20	11	86	60
A44.806.025.042	63	WH2	25	14	42	16
A44.806.025.086	63	WH2	25	14	86	60
A44.806.025.126	63	WH2	25	14	126	100
A44.806.032.048	63	WH3	32	18	48	22
A44.806.032.100	63	WH3	32	18	100	74
A44.806.040.055	63	WH4	40	22	55	29
A44.806.040.100	63	WH4	40	22	100	74
A44.806.050.065	63	WH5	50	28	65	39
A44.806.050.100	63	WH5	50	28	100	74
A44.806.063.080	63	WH6	63	36	80	54
A44.810.050.065	100	WH5	50	28	65	36
A44.810.063.080	100	WH6	63	36	80	51
A44.810.080.080	100	WH8	80	36	80	51

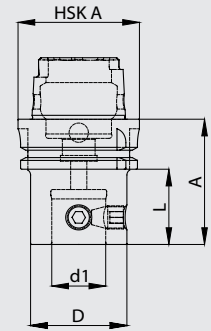

Bestell-Nr. / Order number	PSC	WH	D	d1	A	L
A51.806.020.054	63	WH1	20	11	54	32
A51.806.025.054	63	WH2	25	14	54	32
A51.806.032.054	63	WH3	32	18	54	32
A51.806.040.065	63	WH4	42	22	65	43
A51.806.050.065	63	WH5	50	28	65	43
A51.806.063.080	63	WH6	63	36	80	-
A51.806.080.080	63	WH8	80	36	80	-

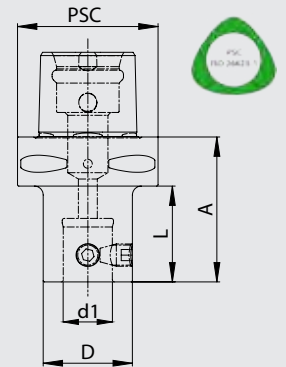

Bestell-Nr. / Order number	ISO	WH	D	d1	A	L	M
A54.300.050.040	30	WH5	50	28	40	-	M12
A54.400.040.040	40	WH4	40	22	40	28.4	M16
A54.400.050.040	40	WH5	50	28	40	28.4	M16
A54.400.063.063	40	WH6	63	36	63	-	M16
A54.500.050.042	50	WH5	50	28	42	26.8	M24
A54.500.063.052	50	WH6	63	36	52	36.8	M24
A54.500.080.052	50	WH8	80	36	52	36.8	M24

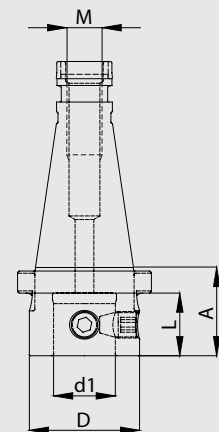

## Ersatzteile / Zubehör

## Spare parts / Accessories

A14/A34/A44/A51/  
A54/A64/A84

Für WH/ For WH	Bestell-Nr. /Order number
	Klemmschraube /Clamping screw ①
WH1	J00.100.005.008
WH2	J00.100.008.008
WH3	J00.100.008.010
WH4	J00.100.010.015
WH5	J00.100.012.017
WH6	J00.100.016.021
WH8	J00.100.016.029

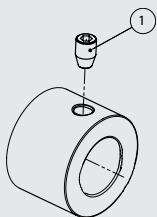

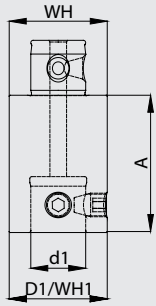

Bestell-Nr. / Order number	WH	WH1	D1	d1	A
A64.020.020.025	WH1	WH1	20	11	25
A64.020.020.035	WH1	WH1	20	11	35
A64.025.025.030	WH2	WH2	25	14	30
A64.025.025.045	WH2	WH2	25	14	45
A64.032.032.040	WH3	WH3	32	18	40
A64.032.032.060	WH3	WH3	32	18	60
A64.039.039.050	WH4	WH4	40	22	50
A64.039.039.080	WH4	WH4	40	22	80
A64.050.050.050	WH5	WH5	50	28	50
A64.050.050.070	WH5	WH5	50	28	70
A64.050.050.100	WH5	WH5	50	28	100
A64.063.063.075	WH6	WH6	63	36	75
A64.063.063.135	WH6	WH6	63	36	135
A64.080.080.100	WH8	WH8	80	36	100
A64.080.080.180	WH8	WH8	80	36	180



**Reduktionen**

**Reductions**

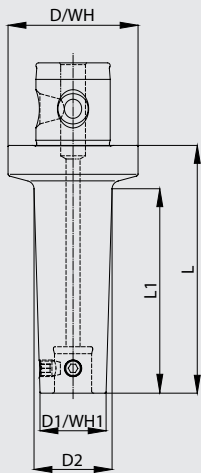

Bestell-Nr. / Order number	WH	D	WH1	D1	D2	L	L1	L2
A84.025.020.036	WH2	25	WH1	20	23	36	26	69
A84.032.020.038	WH3	32	WH1	20	23	38	26	69
A84.032.025.038	WH3	32	WH2	25	29	38	26	82
A84.040.020.040	WH4	40	WH1	20	23	40	26	69
A84.040.025.040	WH4	40	WH2	25	29	40	26	82
A84.040.032.040	WH4	40	WH3	32	38	40	26	92
A84.050.020.044	WH5	50	WH1	20	23	44	28	73
A84.050.020.080	WH5	50	WH1	20	23	80	64	107
A84.050.025.044	WH5	50	WH2	25	29	44	28	84
A84.050.025.090	WH5	50	WH2	25	29	90	74	128
A84.050.032.044	WH5	50	WH3	32	38	44	28	94
A84.050.032.100	WH5	50	WH3	32	38	100	84	148
A84.050.040.044	WH5	50	WH4	40	48	44	28	103
A84.050.040.115	WH5	50	WH4	40	48	115	99	172
A84.063.020.050	WH6	63	WH1	20	23	50	32	77
A84.063.020.100	WH6	63	WH1	20	23	100	82	125
A84.063.025.050	WH6	63	WH2	25	29	50	32	88
A84.063.025.110	WH6	63	WH2	25	29	110	92	146
A84.063.032.050	WH6	63	WH3	32	38	50	32	98
A84.063.032.120	WH6	63	WH3	32	38	120	102	166
A84.063.040.050	WH6	63	WH4	40	48	50	32	122
A84.063.040.140	WH6	63	WH4	40	48	140	122	195
A84.063.050.050	WH6	63	WH5	50	60	50	32	142
A84.063.050.160	WH6	63	WH5	50	60	160	142	230
A84.080.063.060	WH8	80	WH6	63	75	60	40	180

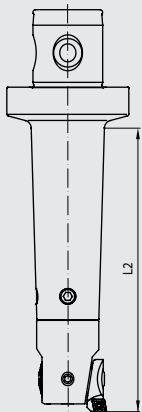

• Länge L2 bezeichnet die maximale Ausdrehtiefe mit Zweischneider- oder Feinbohrkopf

• length L2 stands for the maximal boring depth with twin cutter or fine boring head





- Durchmessereinstellung mit geringstem Umkehrspiel
- Zustellgenauigkeit von 0.002mm über Nonius im Durchmesser
- mit Innenkühlung
- diametrical adjustment with maximal reduced reversal backlash
- 0.002mm diametrical adjustment by nonius
- with inner coolant supply

Bestell-Nr. / Order number	D	D1	D2	X	L	L1
B04.010.025.025	4	10	25	1.5	25	25
B04.016.032.032	7	16	32	2.5	32	40

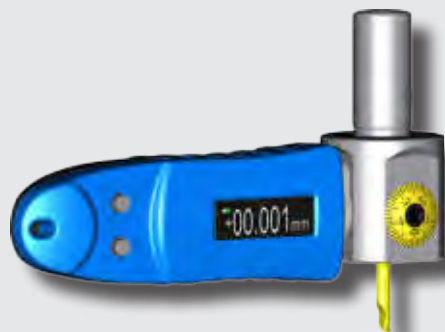
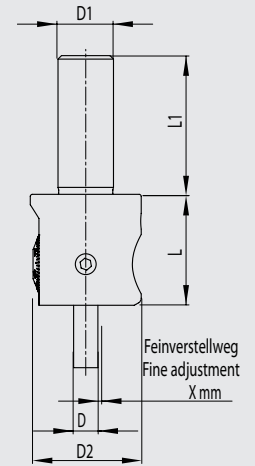

- Einstellgenauigkeit 0.001mm im Durchmesser
- direktes Wegmeßsystem (kein Umkehrspiel)
- keine Batterie und Auswerteelektronik im Werkzeug verbaut
- sehr einfache Bedienung
- digital und analog einsetzbar
- 0.001 accuracy in diameter
- direct measurement system (no backlash)
- no battery and electronic evaluation unit inside the tool
- very easy operation
- for digital and analog use

Bestell-Nr. / Order number	D	D1	D2	X	L	L1
<i>DIGITAL</i>						
B06.010.025.025	4	10	25	1.5	25	25
B06.016.032.032	7	16	32	2.5	32	40

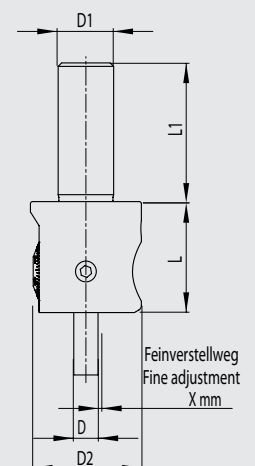

- Anzeigeeinheit muss separat bestellt werden siehe Seite 6 (C09.028.024.077).
- Display unit must be ordered separately see page 6 (C09.028.024.077).

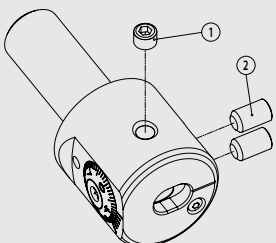

Ersatzteile / Zubehör

Spare parts / Accessories

B04/B06

Für Ausdrehkopf For boring head	Bestell-Nr. / Order number	Bestell-Nr. / Order number
	Klemmschraube/ Clamping screw ①	Befestigungsschraube / Fastening screw ②
B04/B06.010.025.025	J00.204.005.004	J00.204.004.008
B04/B06.016.032.032	J00.204.006.005	J00.204.006.010

**Reduktionshülsen**

**Reduction sleeves**

**B24**

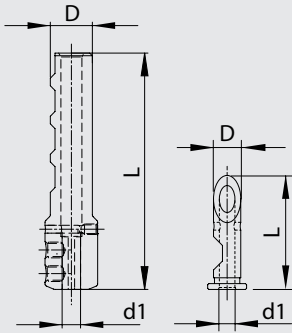

Bestell-Nr. / Order number	D	d1	L
B24.007.004.030	7	4	(30)
B24.016.004.090	16	4	90
B24.016.007.090	16	7	90



**Schneideinsätze**

**Boring bars**

**B55**

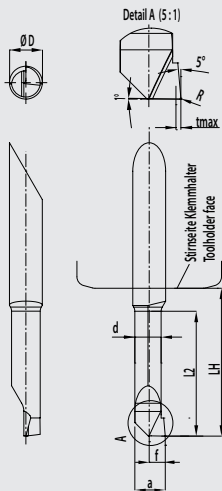

Bestell-Nr. / Order number	ØD	L2	Ød min	Ød max	R	a	d	f	LH	t max
B55.004.003.013	4.0	1.2	0.3	0.7	-	0.25	0.15	0.15	11.0	0.03
B55.004.006.013	4.0	2.5	0.6	1.1	-	0.55	0.46	0.30	11.0	0.05
B55.004.010.013	4.0	4.0	1.0	2.3	0.05	0.95	0.65	0.50	11.0	0.1
B55.004.022.013	4.0	6.0	2.2	3.3	0.05	2.00	1.55	1.10	11.0	0.2
B55.004.032.013	4.0	10.2	3.2	4.3	0.05	3.00	2.55	1.60	11.0	0.2
B55.004.039.018	4.0	15.2	3.9	(7.1)	0.05	3.70	3.45	1.95	16.0	0.3
B55.007.052.023	7.0	20.3	5.2	6.3	0.05	5.00	4.25	2.60	21.0	0.5
B55.007.062.023	7.0	20.3	6.2	7.3	0.05	6.00	5.25	3.10	21.0	0.5
B55.007.069.028	7.0	25.4	6.9	(12.1)	0.20	6.70	6.25	3.45	26.0	0.5

• Schnittwerte (Start) f 0.02 mm/U

• Cutting parameters (Start) f 0.02 mm/rev

**Schneidplatten**

**inserts**

**B83**

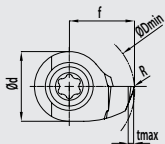

Bestell-Nr. / Order number	Ød min	Ød max	R	f	Ød	tmax	Code
B83.007.069.004	6.9	8.1	0.2	3.45	4.8	1.0	D07
B83.007.079.004	7.9	9.1	0.2	3.95	4.8	1.0	D07
B83.007.089.004	8.9	10.1	0.2	4.45	4.8	1.0	D07
B83.010.099.004	9.9	12.1	0.2	4.95	7	1.0	D10
B83.010.119.004	11.9	14.1	0.2	5.95	7	1.0	D10
B83.010.139.004	13.9	19.1	0.2	6.95	7	1.0	D10

• Schnittwerte (Start) f 0.02 mm/U

• Cutting parameters (Start) f 0.02 mm/rev

**Adapter  
für Schneidplatten**

**Adapter  
for inserts**

**B82**

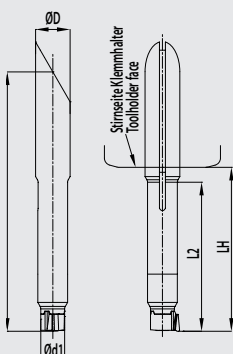

Bestell-Nr. / Order number	ØD h6	L2	Ød1	L1	LH	Schraube/ screw ①	Torx	Code
B82.007.007.033	7.0	30	4.8	56	31	M2x7.5 (J00.254.020.007)	T7	D07
B82.007.010.038	7.0	35	7.0	61	36	M3x9.0 (J00.254.030.009)	T9	D10

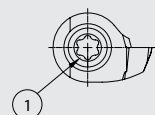

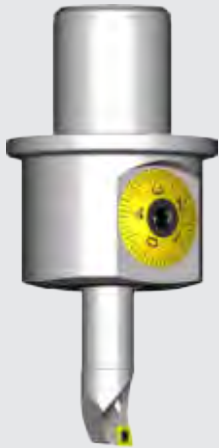

- für Ausdrehstähle mit Schaftdurchmesser 16mm
- DurchmesserEinstellung mit geringstem Umkehrspiel
- Zustellgenauigkeit von 0.01mm resp. über Nonius 0.002mm im Durchmesser
- mit Innenkühlung
- Ausdrehstähle durchschiebbar
- for boring bars with a shank diameter of 16mm
- diametrical adjustment with maximal reduced reversal backlash
- 0.01mm diametrical adjustment resp. 0.002mm by nonius
- with inner coolant supply
- boring bars go through head

Bestell-Nr. / Order number	System	D1	ø A min.	ø A max.	L (A)	L1
<b>WH modular ANALOG</b>						
B04.050.025.050	WH5	55	3	88.1	50	-
B04.063.025.050	WH6	55	3	88.1	50	-
<b>DIN 69893 HSK 63 A</b>						
B08.806.055.095	HSK 63 A	55	3	88.1	95	69
<b>DIN 69871 AD 40</b>						
B08.440.055.090	ISO 40	55	3	88.1	90	70
<b>MAS BT 40</b>						
B08.540.055.090	BT40	55	3	88.1	90	63

- die Ausdrehdurchmesser ø A min. - A max. werden mit Ausdrehstäben der Serien B54 bis B94 erreicht
- boring diameter ø A min. - A max. are only available with boring bars from series B54 to B94

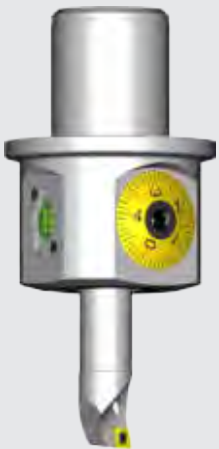
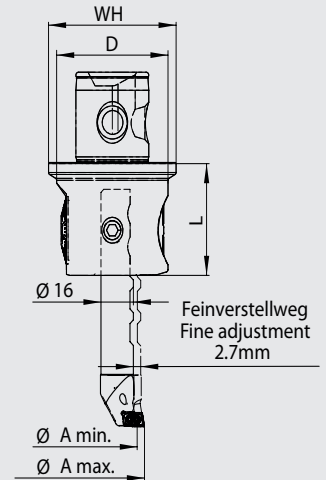

- für Ausdrehstähle mit Schaftdurchmesser 16mm
- Einstellgenauigkeit 0.001mm im Durchmesser
- direktes Wegmeßsystem (kein Umkehrspiel)
- keine Batterie und Auswerteelektronik im Werkzeug verbaut
- sehr einfache Bedienung
- digital und analog einsetzbar
- mit Innenkühlung
- Ausdrehstähle durchschiebbar
- for boring bars with a shank diameter of 16mm
- 0.001 accuracy in diameter
- direct measurement system (no backlash)
- no battery and electronic evaluation unit inside the tool
- very easy operation
- for digital and analog use
- with inner coolant supply
- boring bars go through head

Bestell-Nr. / Order number	System	D1	ø A min.	ø A max.	L (A)	L1
<b>WH modular DIGITAL</b>						
B06.050.025.050	WH5	55	3	88.1	50	-
B06.063.025.050	WH6	55	3	88.1	50	-
<b>DIN 69893 HSK 63 A</b>						
B09.806.055.095	HSK 63 A	55	3	88.1	95	69
<b>DIN 69871 AD 40</b>						
B09.440.055.090	ISO 40	55	3	88.1	90	70
<b>MAS BT 40</b>						
B09.540.055.090	BT40	55	3	88.1	90	63

- die Ausdrehdurchmesser ø A min. - A max. werden mit Ausdrehstäben der Serien B54 bis B94 erreicht
- Anzeigeeinheit muss separat bestellt werden siehe Seite 6 (C09.028.024.077).
- boring diameter ø A min. - A max. are only available with boring bars from series B54 to B94
- Display unit must be ordered separately see page 6 (C09.028.024.077).

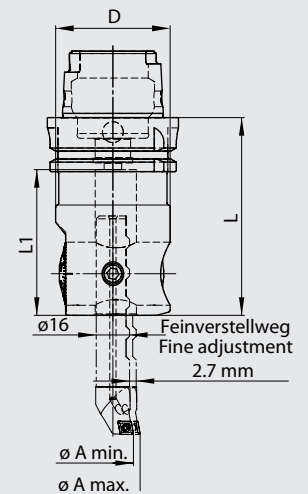
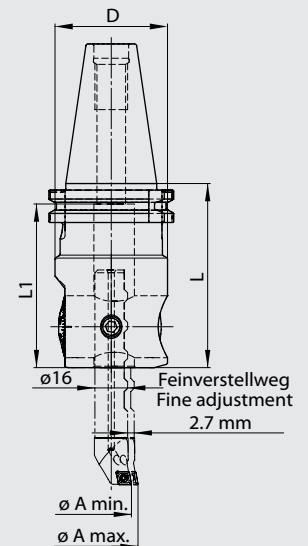

- Schnittstelle ER32 DIN6499

- connection ER32 DIN 6499

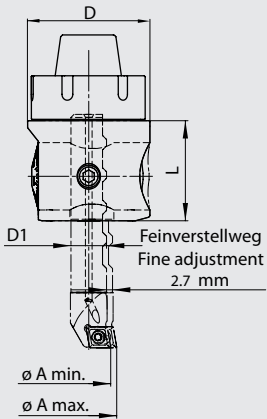

Bestell-Nr. / Order number	Ø D/ System	Ø A min.	Ø A max.	L (A)	L1
<b>SMART ER32</b>					
B11.032.055.060	55 / ER32	9.75	88.1	60	-

- Werkzeug in einem Spannzangenfutter spannen.
- Clamp tool in a collet chuck.



**Ausdrehköpfe ø3-88.1  
DIGITAL**

**Fine boring heads ø3-88.1  
DIGITAL**

**PSC FBHO**

- für Ausdrehstähle mit Schaftdurchmesser 16mm
- Einstellgenauigkeit 0.001mm im Durchmesser
- direktes Wegmeßsystem (kein Umkehrspiel)
- keine Batterie und Auswerteelektronik im Werkzeug verbaut
- sehr einfache Bedienung
- digital und analog einsetzbar
- mit Innenkühlung

- for boring bars with a shank diameter of 16mm
- 0.001 accuracy in diameter
- direct measurement system (no backlash)
- no battery and electronic evaluation unit inside the tool
- very easy operation
- for digital and analog use
- with inner coolant supply

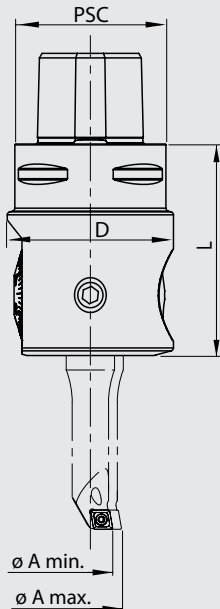

Bestell-Nr. / Order number	System	D1	Ø A min.	Ø A max.	L (A)	L1
<b>PSC DIGITAL</b>						
PSC40-FBHO-DE-1665	PSC40	55	3	88.1	65	-
PSC50-FBHO-DE-1670	PSC50	55	3	88.1	70	-
PSC63-FBHO-DE-1690	PSC63	55	3	88.1	90	-

- die Ausdrehdurchmesser ø A min. - A max. werden mit Ausdrehstäben der Serien B54 bis B94 erreicht
- boring diameter ø A min. - A max. are only available with boring bars from series B54 to B94



- Anzeigeeinheit muss separat bestellt werden siehe Seite 6 (C09.028.024.077).
- Display unit must be ordered separately see page 6 (C09.028.024.077).





- Schnittstelle ER40 DIN6499
- Zustellgenauigkeit 0.01mm resp. über Nonius 0.002mm im Durchmesser
- erweiterbar von ø3 bis ø152.1

- connection ER40 DIN 6499
- 0.01mm diametrical adjustment resp. 0.002mm by nonius
- can be upgraded from ø3 up to ø152.1

Bestell-Nr. / Order number	Ø D / System	Ø A min. - max.	Ø A1 min. - max.	L (A)	L2
<b>VARIO ER40</b>					
B05.040.003.152	63 / ER40	3 - 88.1	87.75 - 152.1	50.5	57

- die Ausdrehdurchmesser ø A min. - A max. werden mit Ausdrehstäben der Serien B54 bis B94 erreicht

- boring diameter ø A min. - A max. are only available with boring bars from series B54 to B94

Zubehör	Accessories
Wendeplattenhalter / Insert holder CC . . 09 T3 . .	ø 87.75 - 101.1 (ø 114.1) C14.726.001.009
Wendeplattenhalter / Insert holder CC . . 09 T3 . .	ø 105.75 - 119.0 (ø 132.0) C14.726.002.009
Wendeplattenhalter / Insert holder CC . . 09 T3 . .	ø 125.75 - 139.0 (ø 152.0) C14.726.003.009
Distanzstück / Adapter F = 6.5 mm	ø 114.0 / ø 132.0 / ø 152.0 J00.803.001.006

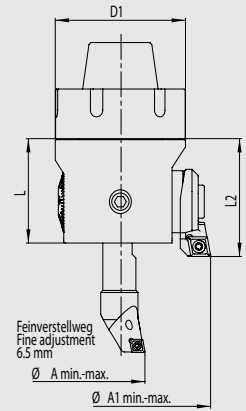

- für Ausdrehstäbe mit Schaftdurchmesser 16mm
- Durchmesserereinstellung mit geringstem Umkehrspiel
- Zustellgenauigkeit von 0.01mm resp. über Nonius 0.002mm im Durchmesser
- mit Innenkühlung
- Ausdrehstäbe durchschiebbar

- for boring bars with a shank diameter of 16mm
- diametrical adjustment with maximal reduced reversal backlash
- 0.01mm diametrical adjustment resp. 0.002mm by nonius
- with inner coolant supply
- boring bars go through head

Bestell-Nr. / Order number	System	L	L2	Ø A min. - max.	Ø A1 min. - max.
B05.063.025.050	WH6	50	57	3 - 88.1	87.75 - 152.1

- die Ausdrehdurchmesser ø A min. - A max. werden mit Ausdrehstäben der Serien B54 bis B94 erreicht

- boring diameter ø A min. - A max. are only available with boring bars from series B54 to B94

Zubehör	Accessories
Wendeplattenhalter / Insert holder CC . . 09 T3 . .	ø 87.75 - 101.1 (ø 114.1) C14.726.001.009
Wendeplattenhalter / Insert holder CC . . 09 T3 . .	ø 105.75 - 119.0 (ø 132.0) C14.726.002.009
Wendeplattenhalter / Insert holder CC . . 09 T3 . .	ø 125.75 - 139.0 (ø 152.0) C14.726.003.009
Distanzstück / Adapter F = 6.5 mm	ø 114.0 / ø 132.0 / ø 152.0 J00.803.001.006

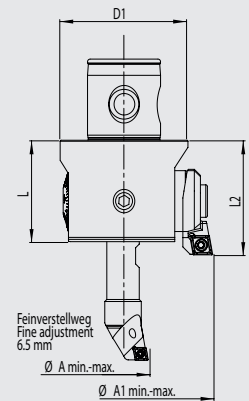



**Ausdrehkopf ø3-320**

**Fine boring head ø3-320**

**B10**

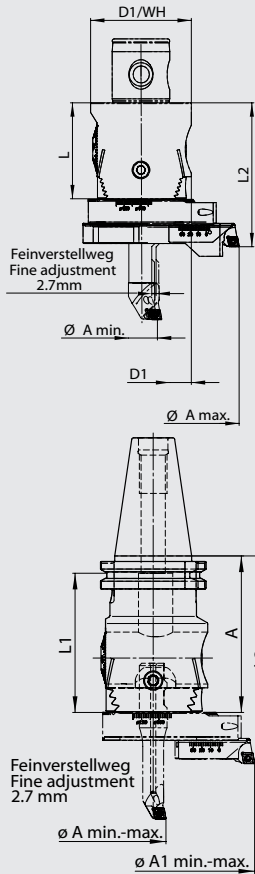

- für Ausdrehstähle mit Schaftdurchmesser 16mm und Feinbohrbrücken
- DurchmesserEinstellung mit geringstem Umkehrspiel
- Zustellgenauigkeit von 0.01mm resp. über Nonius 0.002mm im Durchmesser
- mit Innenkühlung
- Ausdrehstähle durchschiebbar

- for boring bars with a shank diameter of 16mm and fine boring bridges
- diametrical adjustment with maximal reduced reversal backlash
- 0.01mm diametrical adjustment resp. 0.002mm by nonius
- with inner coolant supply
- boring bars go through head

Bestell-Nr. / Order number	System	D1	ø A min.-max.	ø A1 min.-max.	L (A)	L1	L2
<b>WH6 modular</b>							
B10.063.025.060	WH6	63	3 - 88.1	86 - 320	60	-	89
<b>DIN 69893 HSK 63 A</b>							
B10.806.063.095	HSK 63 A	63	3 - 88.1	86 - 320	96	72	125
<b>DIN 69871 AD 40</b>							
B10.440.063.090	ISO 40	63	3 - 88.1	86 - 320	91	81	120
<b>MAS BT 40</b>							
B10.540.063.090	BT40	63	3 - 88.1	86 - 320	91	81	120



- die Ausdrehdurchmesser ø A min.-max. werden mit Ausdrehstählen der Serien B54 bis B94 erreicht
- die Ausdrehdurchmesser ø A1 min.-max. werden mit Feinbohrbrücken der Serie B12 erreicht

- boring diameters ø A min.-max. are only available with boring bars from series B54 to B94
- boring diameters ø A1 min.-max. are only available with fine boring bridges from serie B12

**Feinbohrbrücken ø86-320**

**Fine boring bridges ø86-320**

**B12/B56**

**Aluminium-Brücken**

**Aluminium bridges**

- mit Innenkühlung

- with inner coolant supply

Bestell-Nr. / Order number	D	ø A min.	ø A max.
B12.086.164.080	80	86	164
B12.162.320.158	158	162	320



**Wendeplattenhalter**

**Insert holders**

- mit Innenkühlung

- with inner coolant supply

Bestell-Nr. / Order number	Wendeplatte / Insert	ø A min.	ø A max.
B56.048.006.014	CC . . 06 02 . .	86	320
B56.048.009.014	CC . . 09 T3 . .	86	320



**Gegengewicht**

**Counter weight**

- für hohe Drehzahlen

- for high revolution speed

Bestell-Nr. / Order number
B12.038.045.012



**Ersatzteile / Zubehör**

**Spare parts / Accessories**

**B04/B06/B08/B10**

Für Ausdrehkopf / For boring head	Bestell-Nr. / Order number <sup>(2)</sup>	Bestell-Nr. / Order number <sup>(3)</sup>	Bestell-Nr. / Order number <sup>(4)</sup>
	Klemmschraube / Clamping screw	Befestigungsschraube / Fastening screw	Befestigungsschraube / Fastening screw
B10.063.025.060	J00.210.006.016	J00.210.010.020	J00.256.005.016
B04/B06.063.025.050	J00.204.010.008	J00.204.010.016	
Für Wp-Halter / For insert holder	Bestell-Nr. / Order number <sup>(5)</sup>	Bestell-Nr. / Order number	
	Torx-Schraube / Torx screw	Torx-Schlüssel / Torx driver	
B56.xxx.006.xxx	J00.254.025.006	J00.254.007.000	
B56.xxx.009.xxx	J00.254.040.009	J00.254.009.000	

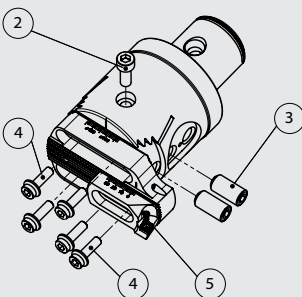



Bestell-Nr. / Order number	ø A min.	ø A max.	L	HM Sorte / Carbide quality
B64.003.010.020	3.0	8.0	20	K10
B64.003.020.020	3.0	8.0	20	P20
B64.004.010.023	4.0	9.0	23	K10
B64.004.020.023	4.0	9.0	23	P20
B64.005.010.025	5.0	10.0	25	K10
B64.005.020.025	5.0	10.0	25	P20
B64.006.010.028	6.0	11.0	28	K10
B64.006.020.028	6.0	11.0	28	P20
B64.007.010.031	7.0	12.0	31	K10
B64.007.020.031	7.0	12.0	31	P20
B64.009.010.034	9.0	14.0	34	K10
B64.009.020.034	9.0	14.0	34	P20
B64.010.010.037	10.0	15.0	37	K10
B64.010.020.037	10.0	15.0	37	P20
B64.012.010.040	12.0	17.0	40	K10
B64.012.020.040	12.0	17.0	40	P20
B64.014.010.043	14.0	19.0	43	K10
B64.014.020.043	14.0	19.0	43	P20

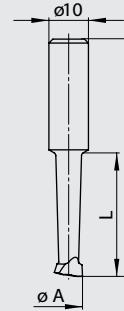

- die Ausdrehdurchmesser ø A min. - A max. werden mit Ausdrehköpfen der Serien B04 bis B10 erreicht
- Hartmetall Sorte K10 für Guss, Aluminium usw.
- Hartmetall Sorte P20 für Stahl, Chromnickelstahl usw.
- boring diameters ø A min. - A max. are only available with fine boring heads from series B04 to B10
- carbide quality K10 for cast iron, aluminium etc.
- carbide quality P20 for steel, chrome nickel steel etc.



Bestell-Nr. / Order number	ø A min.	ø A max.	D	L	L1	Wendeplatte / Insert
B74.006.002.080	5.8	11.2	5	50	85	WC .. 02 01 ..
B74.008.002.100	7.8	13.2	6	60	95	WC .. 02 01 ..
B74.010.006.120	9.8	15.0	8	80	120	CC .. 06 02 ..
B74.014.006.140	13.8	19.0	10	100	140	CC .. 06 02 ..
B74.018.009.170	17.8	23.0	12	120	170	CC .. 09 T3 ..
B74.022.009.210	21.8	27.0	16	160	210	CC .. 09 T3 ..

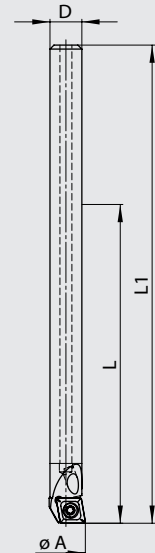

- Länge L bezeichnet die maximale Ausdrehlänge
- die Ausdrehdurchmesser ø A min. - A max. werden mit Ausdrehköpfen der Serien B04 bis B10 erreicht
- length L stands for the maximal boring depth
- boring diameters ø A min. - A max. are only available with fine boring heads from series B04 to B10

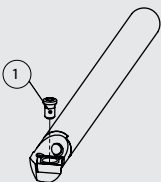

Für Ausdrehstahl For boring bar	Bestell-Nr. / Order number	Bestell-Nr. / Order number
	Torx-Schraube / Torx screw (1)	Torx-Schlüssel / Torx driver
B74.xxx.002.xxx	J00.254.020.004	J00.254.006.000
B74.010.006.120	J00.254.025.005	J00.254.007.000
B74.xxx.006.xxx	J00.254.025.006	J00.254.007.000
B74.xxx.009.xxx	J00.254.040.009	J00.254.009.000

- zum Ausdrehen von langen Bohrungen
- sehr gute Dämpfungseigenschaften durch Hartmetallschaft
- mit Innenkühlung
- to machine long holes
- high end absorbability by solid carbide shank
- with inner coolant supply

Kopf / head Bestell-Nr. / Order number	ø A min.	ø A max.	D	L max.	L2	Wende- platte / Insert	für Schaft / for shank Bestell-Nr. / Order number
B94.009.006.018	8.75	14.1	8	56	18	CC..06 02..	B84.008.005.073
B94.010.006.018	9.75	15.1	9	63	18	CC..06 02..	B84.009.005.080
B94.011.006.023	10.75	16.1	10	70	23	CC..06 02..	B84.010.006.082
B94.012.006.023	11.75	17.1	11	77	23	CC..06 02..	B84.011.006.089
B94.013.006.023	12.75	18.1	12	84	23	CC..06 02..	B84.012.006.096
B94.014.006.023	13.75	19.1	13	91	23	CC..06 02..	B84.013.006.103
B94.015.006.023	14.75	20.1	14	98	23	CC..06 02..	B84.014.006.110
B94.016.006.023	15.75	21.1	14	98	23	CC..06 02..	B84.014.006.110
B94.017.006.027	16.75	22.1	16	112	27	CC..06 02..	B84.016.010.120
B94.018.006.027	17.75	23.1	16	112	27	CC..06 02..	B84.016.010.120
B94.020.006.027	19.75	25.1	16	112	27	CC..06 02..	B84.016.010.120
B94.022.006.027	21.75	27.1	16	112	27	CC..06 02..	B84.016.010.120
B94.025.006.027	24.75	30.1	16	112	27	CC..06 02..	B84.016.010.120
B94.028.006.027	27.75	33.1	16	112	27	CC..06 02..	B84.016.010.120
B94.032.006.027	31.75	37.1	16	112	27	CC..06 02..	B84.016.010.120
B94.035.006.027	34.75	40.1	16	112	27	CC..06 02..	B84.016.010.120

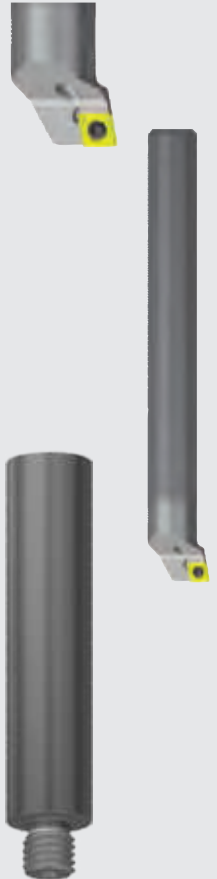
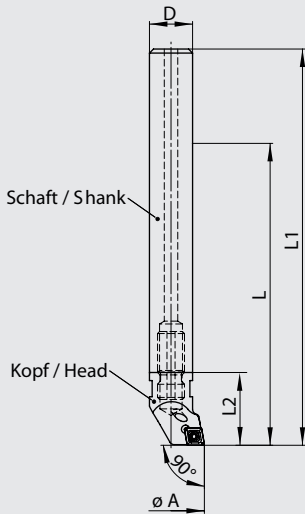

**Hartmetallschaft**

**Solid carbide shank**

Schaft / shank Bestell-Nr. / Order number	D	L1	für Kopf / for head Bestell-Nr. / Order number
B84.008.005.073	8	91	B94.009.006.018
B84.009.005.080	9	98	B94.010.006.018
B84.010.006.082	10	105	B94.011.006.023
B84.011.006.089	11	112	B94.012.006.023
B84.012.006.096	12	119	B94.013.006.023
B84.013.006.103	13	126	B94.014.006.023
B84.014.006.110	14	133	B94.015/016.006.023
B84.016.010.120	16	147	B94.017/018/020/022/025//028/032/035.006.027

**Reduktionshülsen**

**Reduction sleeves**

**B24**

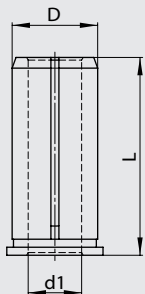

Bestell-Nr. / Order number	D	d1	L
B24.016.004.037	16	4	37
B24.016.005.037	16	5	37
B24.016.006.037	16	6	37
B24.016.008.037	16	8	37
B24.016.009.037	16	9	37
B24.016.010.037	16	10	37
B24.016.011.037	16	11	37
B24.016.012.037	16	12	37
B24.016.013.037	16	13	37
B24.016.014.037	16	14	37



**Ersatzteile / Zubehör**

**Spare parts / Accessories**

**B94**

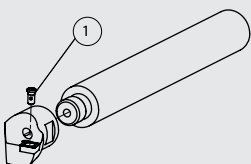

Für Kopf For head	Bestell-Nr. / Order number	Bestell-Nr. / Order number
	Torx-Schraube / Torx screw	Torx-Schlüssel / Torx driver
B94.009-012.006.xxx	J00.254.025.005	J00.254.007.000
B94.013-035.006.xxx	J00.254.025.006	J00.254.007.000

- mit Innenkühlung
- werden die Ausdrehstähle zentrisch gespannt (Weldonfutter), kann mit ø A min. ausgedreht werden

- with inner coolant supply
- if the boring bars are clamped centrally (weldon adapter), the minimum diameter (ø A min.) is provided



Bestell-Nr. / Order number	ø A min.	ø A max.	L	L1	Wendeplatte / Insert
B54.010.006.075	9.75	15.1	30	75	CC .. 06 02 ..
B54.012.006.080	11.75	17.1	37	80	CC .. 06 02 ..
B54.014.006.085	13.75	19.1	43	85	CC .. 06 02 ..
B54.015.006.090	14.75	20.1	51	90	CC .. 06 02 ..
B54.016.006.095	15.75	21.1	57	95	CC .. 06 02 ..
B54.018.006.100	17.75	23.1	67	100	CC .. 06 02 ..
B54.020.006.105	19.75	25.1	72	105	CC .. 06 02 ..
B54.020.009.105	19.75	25.1	72	105	CC .. 09 T3 ..
B54.022.009.110	21.75	27.1	77	110	CC .. 09 T3 ..
B54.025.006.115	24.75	30.1	82	115	CC .. 06 02 ..
B54.025.009.115	24.75	30.1	82	115	CC .. 09 T3 ..

- Länge L bezeichnet die maximale Ausdrehlänge
- die Ausdrehdurchmesser ø A min. - A max. werden mit Ausdrehköpfen der Serien B04 bis B10 erreicht

- length L stands for the maximal boring depth
- boring diameters ø A min. - A max. are only available with fine boring heads from series B04 to B10

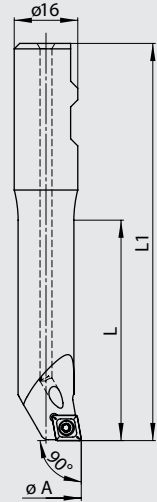

- mit Innenkühlung
- werden die Ausdrehstähle zentrisch gespannt (Weldonfutter), kann mit ø A min. ausgedreht werden

- with inner coolant supply
- if the boring bars are clamped centrally (weldon adapter), the minimum diameter (ø A min.) is provided



Bestell-Nr. / Order number	ø A min.	ø A max.	L	L1	Wendeplatte / Insert
B54.010.T06.075	9.75	15.1	30	75	TB .. 06 01 ..
B54.012.T06.080	11.75	17.1	37	80	TB .. 06 01 ..
B54.014.T09.085	13.75	19.1	43	85	TP .. 09 02 ..
B54.015.T09.090	14.75	20.1	51	90	TP .. 09 02 ..
B54.016.T09.095	15.75	21.1	57	95	TP .. 09 02 ..
B54.018.T09.100	17.75	23.1	67	100	TP .. 09 02 ..
B54.020.T11.105	19.75	25.1	72	105	TP .. 11 03 ..
B54.025.T11.115	24.75	30.1	82	115	TP .. 11 03 ..

- Länge L bezeichnet die maximale Ausdrehlänge
- die Ausdrehdurchmesser ø A min. - A max. werden mit Ausdrehköpfen der Serien B04 bis B10 erreicht

- length L stands for the maximal boring depth
- boring diameters ø A min. - A max. are only available with fine boring heads from series B04 to B10

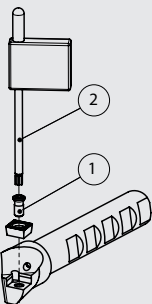
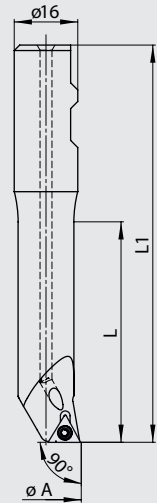

Ersatzteile / Zubehör

Spare parts / Accessories

Für Ausdrehstahl For boring bar	Bestell-Nr. / Order number	Bestell-Nr. / Order number
	Torx-Schraube / Torx screw ①	Torx-Schlüssel / Torx driver ②
B54.010.006.075	J00.254.025.005	J00.254.007.000
B54.xxx.006.xxx	J00.254.025.006	J00.254.007.000
B54.xxx.009.xxx	J00.254.040.009	J00.254.009.000

**Hartmetallschaft**

- sehr gute Dämpfungseigenschaften
- mit Innenkühlung

**Carbide shank**

- high end absorbability
- with inner coolant supply

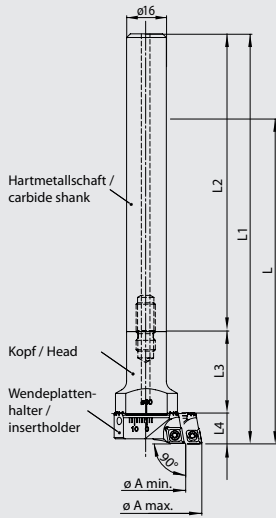

Bestell-Nr. / Order number	D	L2	für Kopf / for head
B84.016.010.120	16	147	B56.030.048.033 B56.048.088.031

**Kopf**

- mit Innenkühlung

**Head**

- with inner coolant supply

Bestell-Nr. / Order number	ø A min.	ø A max.	L	L1	L3	für Wendeplattenhalter / for insert holder
B56.030.048.033	29.75	48.1	135	165	33	B56.030.006.012
B56.048.088.031	47.75	88.1	135	165	31	B56.048.xxx.014



**Stahlschäfte**

- mit Innenkühlung

**Steel shanks**

- with inner coolant supply

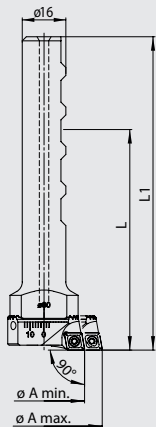

Bestell-Nr. / Order number	ø A min.	ø A max.	L	L1	für Wendeplattenhalter / for insert holder
B56.030.048.115	29.75	48.1	85	115	B56.030.006.012
B56.048.088.115	47.75	88.1	85	115	B56.048.xxx.014



**Wendeplattenhalter**

- mit Innenkühlung

**Insert holders**

- with inner coolant supply

Bestell-Nr. / Order number	ø A min.	ø A max.	L4	Wendeplatte / Insert
B56.030.006.012	29.75	48.1	12	CC . . 06 02 . .
B56.048.006.014	47.75	88.1	14	CC . . 06 02 . .
B56.048.009.014	47.75	88.1	14	CC . . 09 T3 . .



- Schäfte und Wendeplattenhalter müssen separat bestellt werden

- shanks and insert holder must be ordered separately

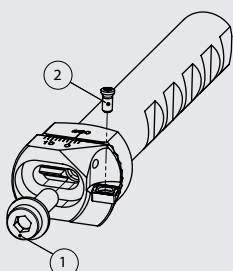

**Ersatzteile / Zubehör**

**Spare parts / Accessories**

**B56**

Für Schaft For shank	Bestell-Nr. / Order number	Für Wp-Halter For insert holder	Bestell-Nr. / Order number	Bestell-Nr. / Order number
	Befestigungsschraube / Fastening screw <sup>①</sup>		Torx-Schraube / Torx screw <sup>②</sup>	Torx-Schlüssel / Torx driver
B56.030.048.115	J00.256.005.016	B56.xxx.006.xxx	J00.254.025.006	J00.254.007.000
B56.048.088.115	J00.256.005.016	B56.xxx.009.xxx	J00.254.040.009	J00.254.009.000

**B00**

**Einstellvorrichtung**

**Setting Jig**



- Orientierung der Werkzeugschneide
- Einstellung der Auskraglänge der Bohrstange
- Grobeinstellung des Ausrehdurchmessers

- alignment of the cutting edge
- adjustment of the boring bar projection length
- coarse diameter adjustment

Bestell-Nr. / Order number	D	L	für Ausdrehkopf/ for fine boring head
B00.055.055.197	55	197	B04 / B08
B00.063.063.197	63	197	B06
B00.163.063.207	63	207	B10

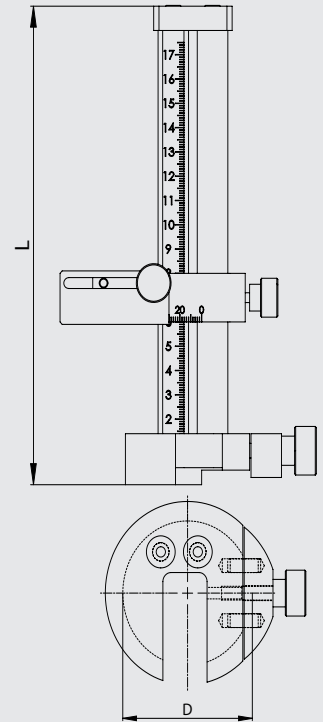
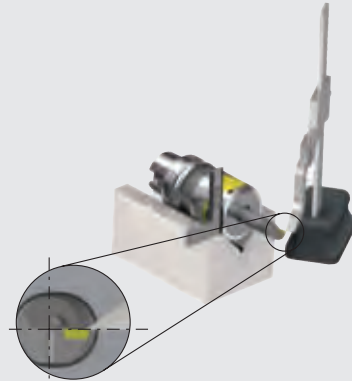

**B16**

**Universal-Auswuchtringe**

**Universal balancing rings**



- zum Auswuchten verstellbarer Werkzeuge, z.B. Ausdrehköpfe der Serien B04 - B06
- für die Ausdrehköpfe der Serie B04 und B06 (mit den Ausdrehstäben der Serie B54, B74, B84, B94) sind Einstelltabelle verfügbar, womit die Unwucht über 90% reduziert wird

- to balance adjustable tools, e.g. fine boring heads from series B04-B06
- balancing charts for fine boring heads from serie B04 and B06 (with boring bars from serie B54, B74, B84, B94) are available in order to reduce unbalance by 90%

Bestell-Nr. / Order number	D	d1	L
B16.055.075.016	75	55	16
B16.063.084.016	84	63	16

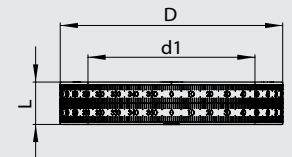

**B34**

**Ausdrehstahl-Verlängerungen**

**Boring bar extensions**



Bestell-Nr. / Order number	D	d1	D2	L	L1
B34.016.010.128	16	10	16	128	-
B34.016.016.148	16	16	24	148	44

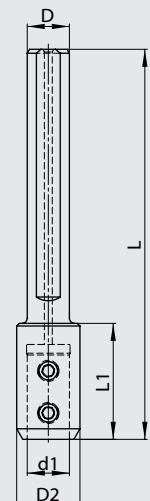

- für die Verwendung in Ausdrehköpfen der Serien B04 bis B10
- mit Innenkühlung

- for use in fine boring heads from series B04 to B10
- with inner coolant supply

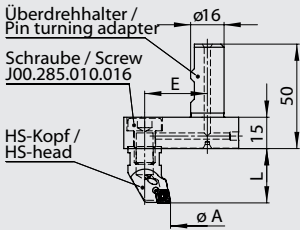

Überdrehhalter / Pin turning adapter Bestell-Nr. / Order number	HS-Kopf / HS-head Bestell-Nr. / Order number	ø A min.	ø A max.	E	L	Wende- platte / Insert
B85.020.010.050	B94.035.006.027	5.3	10.6	20	27	CC..06 02..
B85.020.010.050	B94.032.006.027	8.3	13.6	20	27	CC..06 02..
B85.020.010.050	B94.028.006.027	12.3	17.6	20	27	CC..06 02..
B85.020.010.050	B94.025.006.027	15.3	20.6	20	27	CC..06 02..
B85.020.010.050	B94.022.006.027	18.3	23.6	20	27	CC..06 02..
B85.020.010.050	B94.020.006.027	20.3	25.6	20	27	CC..06 02..
B85.020.010.050	B94.018.006.027	22.3	27.6	20	27	CC..06 02..
B85.020.010.050	B94.017.006.027	23.3	28.6	20	27	CC..06 02..
B85.030.010.050	B94.035.006.027	25.3	30.6	30	27	CC..06 02..
B85.030.010.050	B94.032.006.027	28.3	33.6	30	27	CC..06 02..
B85.030.010.050	B94.028.006.027	32.3	37.6	30	27	CC..06 02..
B85.030.010.050	B94.025.006.027	35.3	40.6	30	27	CC..06 02..
B85.030.010.050	B94.022.006.027	38.3	43.6	30	27	CC..06 02..
B85.030.010.050	B94.020.006.027	40.3	45.6	30	27	CC..06 02..
B85.030.010.050	B94.018.006.027	42.3	47.6	30	27	CC..06 02..
B85.030.010.050	B94.017.006.027	43.3	48.6	30	27	CC..06 02..



- die maximale Überdrehlänge L kann mit der Verlängerung B86.016.016.032 oder B86.016.016.064 verlängert werden
- Überdrehhalter und Kopf müssen separat bestellt werden
- **Achtung: Linkslauf**

- the maximal turning length L can be increased by extension B86.016.016.032 or B86.016.016.064
- pin turning adapter and head must be ordered separately
- **Caution: anticlockwise rotation**

Schaftverlängerungen

Shank extensions

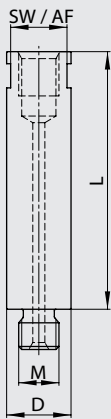

- zur Verlängerung von den Schäften und Überdrehhaltern
- mit Innenkühlung
- aus gehärtetem Stahl

- to extend shanks and pin turning adapters
- with inner coolant supply
- made of hardened steel

Bestell-Nr. / Order number	D	L	M	SW / AF
B86.016.016.032	16	32	M10	14
B86.016.016.064	16	64	M10	14

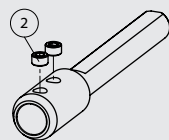

Ersatzteile / Zubehör

Spare parts / Accessories

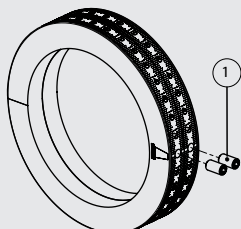

Für Auswuchtring For balancing ring	Bestell-Nr. / Order number	Für Ausdrehstahl-Verlängerung For boring bar extension	Bestell-Nr. / Order number
	Klemmschraube / Clamp screw <sup>1</sup>		Spannschraube / Clamp screw <sup>2</sup>
B16.xxx.xxx.016	J00.216.004.008	B34.016.010.128	J00.234.006.003
		B34.016.016.148	J00.234.008.005



Schaft / shank Bestell-Nr. / Order number	D	L1	für Feinbohrkopf / for fine boring head
B84.014.006.110	14	110	C00.014.015.040
B84.016.010.120	16	120	C00.016.017.040
B84.018.010.100	18	100	C00.019.020.040
B84.018.010.140	18	140	C00.019.020.040

## Stahlschaft

## Steel shank

Schaft / shank Bestell-Nr. / Order number	D	L1	für Feinbohrkopf / for fine boring head
B82.014.006.060	14	60	C00.014.015.040
B82.016.010.070	16	70	C00.016.017.040
B82.018.010.080	18	80	C00.019.020.040

## High-Speed Feinbohrköpfe

## High-Speed fine boring heads

- Durchmessereinstellung mit geringstem Umkehrspiel
- Zustellgenauigkeit von 0.002mm über Nonius im Durchmesser
- mit Innenkühlung

- diametrical adjustment with maximal reduced reversal backlash
- 0.002mm diametrical adjustment by nonius
- with inner coolant supply

Feinbohrkopf / Fine boring head Bestell-Nr. / Order number	D	ø A min.	ø A max.	L	für Wendepaltenhalter / For insert holder (Wendepalte / Insert)
C00.014.015.040	14	14.7	17.1	40	C02.005.017.002 (WC .. 02 01 ..)
C00.016.017.040	16	16.7	20.1	40	C02.005.017.002 (WC .. 02 01 ..)
C00.019.020.040	18	19.7	24.1	40	C02.005.017.002 (WC .. 02 01 ..)

- Feinbohrkopf, Schaft und Wendepaltenhalter müssen separat bestellt werden

- fine boring head, shank and insert holder must be ordered separately

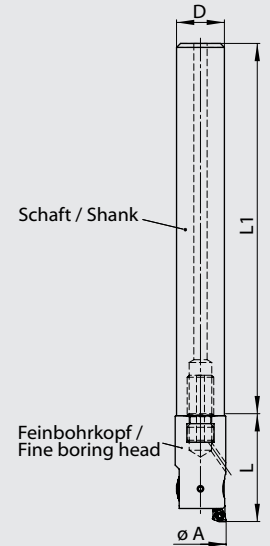

## Ersatzteile / Zubehör

## Spare parts / Accessories

## C00/C04/C05

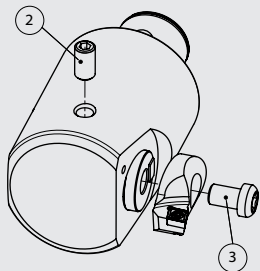

Für Feinbohrkopf For fine boring head	Bestell-Nr. / Order number	Bestell-Nr. / Order number
	Klemmschraube / Clamping screw ②	Befestigungsschraube / Fastening screw ③
C00.014.015.040	J00.881.280.140	J00.882.280.140
C00.016.017.040	J00.881.280.160	J00.882.280.160
C00.019.020.040	J00.881.280.180	J00.288.280.180
C00/C01.020.024.041	J00.304.004.003	J00.314.004.006
C00/C01.025.031.045	J00.304.005.004	J00.314.005.008
C00/C01.032.040.051	J00.304.006.005	J00.314.006.010
C04/C05.020.024.045	J00.304.004.003	J00.314.004.006
C04/C05.025.031.056	J00.304.005.004	J00.314.005.008
C04/C05.032.040.066	J00.304.006.005	J00.314.006.010
C04/C05.040.051.075	J00.304.008.006	J00.314.008.012
C04/C05.050.067.090	J00.304.010.010	J00.314.010.016
C04/C05.063.087.110	J00.304.010.018	J00.314.010.016
C04/C05.080.116.140	J00.304.010.030	J00.314.010.016



- **Typ C00 (analog)** Zustellgenauigkeit von 0.002mm über Nonius im Durchmesser
- **Typ C01 (digital)** Einstellgenauigkeit 0.001mm im Durchmesser direktes Wegmeßsystem (kein Umkehrspiel)
- mit Innenkühlung

- **Type C00 (analog)** 0.002mm diametrical adjustment by nonius
- **Type C01 (digital)** 0.001 accuracy in diameter
- direct measurement system (no backlash)
- with inner coolant supply

Bestell-Nr. / Order number	∅ A min.	∅ A max.	d	L	Wendeplatten- halter / Insert holder
C00/C01.020.024.041	23.9	31.1	20	41	C14.011.024.006
C00/C01.025.031.045	30.9	40.1	25	45	C14.013.031.006
C00/C01.032.040.051	39.9	51.1	32	51	C14.017.040.006

- Wendeplattenhalter müssen separat bestellt werden
- Anzeigeeinheit muss separat bestellt werden siehe Seite 6 (C09.028.024.077).

- insert holders must be ordered separately
- Display unit must be ordered separately see page 6 (C09.028.024.077).

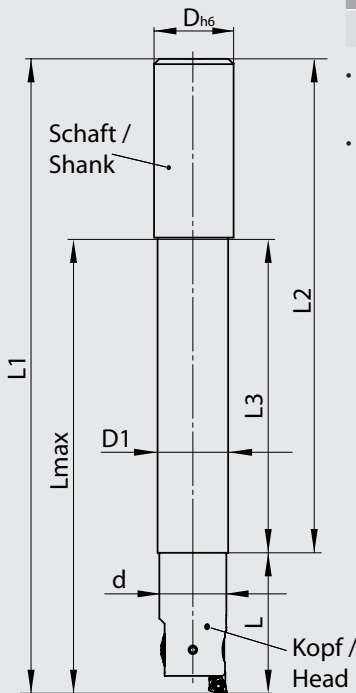

Schwingungsgedämpfte  
Vollhartmetallschäfte

Damped  
solid carbide shanks

B84

- Produktivitätsgewinn dank der unterdrückten Schwingungen können die Schnittdaten beträchtlich erhöht werden
- Verbesserte Oberflächengüte
- Verbesserte Prozesssicherheit
- Verbesserte Spanabfuhr
- Reduzierte Kosten pro Bauteil
- Für Bohrungstiefen bis 12xD

- productivity improvement: thanks to reduced vibrations, the cutting conditions can be improved remarkable
- better surface quality
- improved process stability
- better chip evacuation
- reduced cost per part
- for boring length up to 12xD



Bestell-Nr. / Order number	D	D1	L max	L1	L2	L3	für Einschraubkopf / for screwable head
B84.025.023.170	25	23	146	211	170	105	C00/D00.020.024.041
B84.025.023.220	25	23	196	261	220	155	C00/D00.020.024.041
B84.025.023.265	25	23	241	306	265	200	C00/D00.020.024.041
B84.032.029.220	32	29	200	265	220	155	C00/D00.025.031.045
B84.032.029.260	32	29	240	305	260	195	C00/D00.025.031.045
B84.032.029.310	32	29	290	355	310	245	C00/D00.025.031.045
B84.032.032.217	32	32	203	268	217	152	C00/D00.032.040.051
B84.032.032.287	32	32	273	338	287	222	C00/D00.032.040.051
B84.032.032.357	32	32	343	408	357	292	C00/D00.032.040.051





- Durchmessereinstellung mit geringstem Umkehrspiel
- Zustellgenauigkeit von 0.01mm resp. über Nonius 0.002mm im Durchmesser
- mit Innenkühlung

- diameter setting with minimal reversal backlash
- 0.01mm diametrical adjustment resp. 0.002mm by nonius
- with inner coolant supply

Bestell-Nr. / Order number	Ø D/ System	Ø A min.	Ø A max.	L	Wendeplattenhalter / Insert holder
U20_F20.K21.150	20	23.9	31.1	150	C14.011.024.006 (CC.. 06 02 ..)
U25_F25.K21.170	25	30.9	40.1	170	C14.013.031.006 (CC.. 06 02 ..)

- Werkzeug in einem Spannzangen- oder Hydrodehnfutter spannen.
- **inklusive Wendeplattenhalter**

- Clamp tool in a collet or hydraulik chuck.
- **insert holder included**

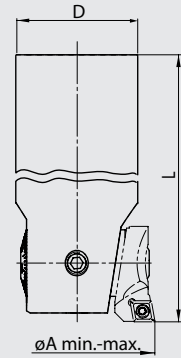

- Durchmessereinstellung mit geringstem Umkehrspiel
- Zustellgenauigkeit von 0.01mm resp. über Nonius 0.002mm im Durchmesser
- mit Innenkühlung

- diameter setting with minimal reversal backlash
- 0.01mm diametrical adjustment resp. 0.002mm by nonius
- with inner coolant supply

Bestell-Nr. / Order number	Ø D/ System	Ø A min.	Ø A max.	L	Wendeplattenhalter / Insert holder
E25_F32.K21.065	32 / ER25	39.9	51.1	65	C14.017.040.006 (CC.. 06 02 ..)
E32_F42.K21.075	42 / ER32	50.9	67.1	75	C14.022.051.006 (CC.. 06 02 ..)
E40_F55.K21.085	55 / ER40	66.9	87.1	85	C14.030.067.009 (CC.. 09 T3 ..)

- Werkzeug in einem Spannzangenfutter spannen.
- **inklusive Wendeplattenhalter**

- Clamp tool in a collet chuck.
- **insert holder included**

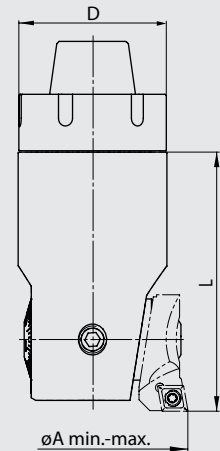

- Einstellgenauigkeit 0.001mm im Durchmesser
- direktes Wegmeßsystem (kein Umkehrspiel)
- keine Batterie und Auswerteelektronik im Werkzeug verbaut
- sehr einfache Bedienung
- digital und analog einsetzbar
- mit Innenkühlung

- 0.001 accuracy in diameter
- direct measurement system (no backlash)
- no battery and electronic evaluation unit inside the tool
- very easy operation
- for digital and analog use
- with inner coolant supply

Bestell-Nr. / Order number	PSC / D	Ø A min.	Ø A max.	L	Wendeplattenhalter / Insert holder
PSC32-FBHS-DE-24	PSC 32 / 20	23.9	31.1	80	C14.011.024.006 (CC.. 06 02 ..)
PSC32-FBHS-DE-31	PSC 32 / 25	30.9	40.1	90	C14.013.031.006 (CC.. 06 02 ..)
PSC40-FBHS-DE-40	PSC 40 / 32	39.9	51.1	90	C14.017.040.006 (CC.. 06 02 ..)
PSC50-FBHS-DE-51	PSC 50 / 42	50.9	67.1	90	C14.022.051.006 (CC.. 06 02 ..)
PSC50-FBHS-DE-67	PSC 50 / 55	65.9	87.1	100	C14.30.067.009 (CC.. 09 T3 ..)
PSC63-FBHS-DE-87	PSC 63 / 72	86.9	116.1	120	C14.30.067.009 (CC.. 09 T3 ..)
PSC63-FBHS-DE-116	PSC 63 / 94	114.9	153.1	150	C14.30.067.009 (CC.. 09 T3 ..)

- **Wendeplattenhalter müssen separat bestellt werden**
- Anzeigeeinheit muss separat bestellt werden siehe Seite 6 (C09.028.024.077).

- **insert holders must be ordered separately**
- Display unit must be ordered separately see page 6 (C09.028.024.077).

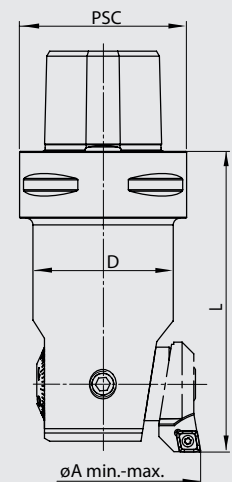

- Durchmessereinstellung mit geringstem Umkehrspiel
- Zustellgenauigkeit von 0.01mm resp. über Nonius 0.002mm im Durchmesser
- mit Innenkühlung
- diametrical adjustment nearly without reversal backlash
- 0.01mm diametrical adjustment resp. 0.002mm by nonius
- with inner coolant supply

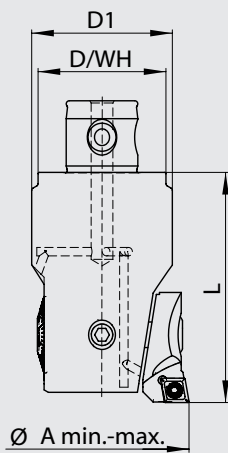

Bestell-Nr. / Order number	ø A min.	ø A max.	WH	D	D1	L	Wendeplattenhalter / Insert holder
C04.020.024.045	23.9	31.1	WH1	20	20	45	C14.011.024.006
	29.9	37.1					C14.011.030.006
C04.025.031.056	30.9	40.1	WH2	25	25	56	C14.013.031.006
	37.9	47.1					C14.013.038.006
C04.032.040.066	39.9	51.1	WH3	32	32	66	C14.017.040.006
	47.9	59.1					C14.017.048.006
C04.040.051.075	50.9	67.1	WH4	40	42	75	C14.022.051.006
	64.9	81.1					C14.022.065.006
C04.050.067.090	66.9	87.1	WH5	50	55	90	C14.030.067.009
	66.9	87.1					C14.030.067.006
C04.063.087.110	84.9	105.1	WH6	63	72	110	C14.030.085.006/9
	86.9	116.1					C14.030.067.009
C04.080.116.140	86.9	116.1	WH8	80	94	140	C14.030.067.006
	104.9	134.1					C14.030.085.006/9
C04.080.116.140	115.9	153.1	WH8	80	94	140	C14.030.067.009
	115.9	153.1					C14.030.067.006
C04.080.116.140	133.9	171.1	WH8	80	94	140	C14.030.085.006/9
	153.9	191.1					C14.726.003.009
C04.080.116.140	165.9*	203.1*	WH8	80	94	140	C14.030.067.009
							C14.030.067.006



- Wendeplattenhalter müssen separat bestellt werden
- \* Hinweis: Dieser Ausdrehbereich wird erreicht mit dem Wendeplattenhalter C14.726.003.009 in Kombination mit dem Distanzstück J00.803.001.006 (S.13).
- insert holders must be ordered separately
- \* Note: For this diameter range the insert holder C14.726.003.009 and the adapter J00.803.001.006 is required (page 13).

**Feinbohrköpfe DIGITAL**

**Fine boring heads DIGITAL**

- Einstellgenauigkeit 0.001mm im Durchmesser
- direktes Wegmeßsystem (kein Umkehrspiel)
- keine Batterie und Auswerteelektronik im Werkzeug verbaut
- sehr einfache Bedienung
- digital und analog einsetzbar
- mit Innenkühlung
- 0.001 accuracy in diameter
- direct measurement system (no backlash)
- no battery and electronic evaluation unit inside the tool
- very easy operation
- for digital and analog use
- with inner coolant supply

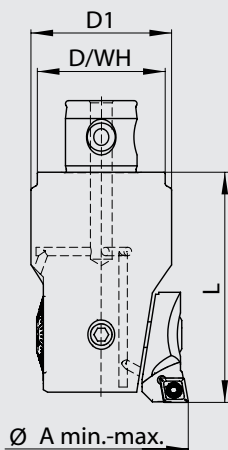

Bestell-Nr. / Order number	ø A min.	ø A max.	WH	D	D1	L	Wendeplattenhalter / Insert holder
C05.020.024.045	23.9	31.1	WH1	20	20	45	C14.011.024.006
	29.9	37.1					C14.011.030.006
C05.025.031.056	30.9	40.1	WH2	25	25	56	C14.013.031.006
	37.9	47.1					C14.013.038.006
C05.032.040.066	39.9	51.1	WH3	32	32	66	C14.017.040.006
	47.9	59.1					C14.017.048.006
C05.040.051.075	50.9	67.1	WH4	40	42	75	C14.022.051.006
	64.9	81.1					C14.022.065.006
C05.050.067.090	66.9	87.1	WH5	50	55	90	C14.030.067.009
	66.9	87.1					C14.030.067.006
C05.063.087.110	84.9	105.1	WH6	63	72	110	C14.030.085.006/9
	86.9	116.1					C14.030.067.009
C05.080.116.140	86.9	116.1	WH8	80	94	140	C14.030.067.006
	104.9	134.1					C14.030.085.006/9
C05.080.116.140	115.9	153.1	WH8	80	94	140	C14.030.067.009
	115.9	153.1					C14.030.067.006
C05.080.116.140	133.9	171.1	WH8	80	94	140	C14.030.085.006/9
	153.9	191.1					C14.726.003.009
C05.080.116.140	165.9*	203.1*	WH8	80	94	140	C14.030.067.009
							C14.030.067.006



- \* Hinweis: Dieser Ausdrehbereich wird erreicht mit dem Wendeplattenhalter C14.726.003.009 in Kombination mit dem Distanzstück J00.803.001.006 (S.13).
- Anzeigeeinheit muss separat bestellt werden siehe Seite 6 (C09.028.024.077).
- \* Note: For this diameter range the insert holder C14.726.003.009 and the adapter J00.803.001.006 is required (page 13).
- Display unit must be ordered separately see page 6 (C09.028.024.077).



- für die Verwendung in Feinbohrköpfen der Serie C04, C05 und E90

- for use in fine boring heads from serie C04, C05 and E90



Bestell-Nr. / Order number	ø A min.	ø A max.	D	Wendeplatte / Insert	Feinbohrkopf / fine boring head
C14.011.024.006	23.9	31.1	11	CC .. 06 02 ..	C04/C05.020.024.045
C14.011.030.006	29.9	37.1	11	CC .. 06 02 ..	C04/C05.020.024.045
C14.013.031.006	30.9	40.1	13	CC .. 06 02 ..	C04/C05.025.031.056
C14.013.038.006	37.9	47.1	13	CC .. 06 02 ..	C04/C05.025.031.056
C14.017.040.006	39.9	51.1	17	CC .. 06 02 ..	C04/C05.032.040.066
C14.017.048.006	47.9	59.1	17	CC .. 06 02 ..	C04/C05.032.040.066
C14.022.051.006	50.9	67.1	22	CC .. 06 02 ..	C04/C05.040.051.075
C14.022.065.006	64.9	81.1	22	CC .. 06 02 ..	C04/C05.040.051.075
C14.030.067.006	66.9	87.1	30	CC .. 06 02 ..	C04/C05.050.067.090
C14.030.067.009	66.9	87.1	30	CC .. 09 T3 ..	C04/C05.050.067.090
C14.030.085.006	84.9	105.1	30	CC .. 06 02 ..	C04/C05.050.067.090
C14.030.085.009	84.9	105.1	30	CC .. 09 T3 ..	C04/C05.050.067.090
C14.030.067.006	86.9	116.1	30	CC .. 06 02 ..	C04/C05.063.087.110
C14.030.067.009	86.9	116.1	30	CC .. 09 T3 ..	C04/C05.063.087.110
C14.030.085.006	104.9	134.1	30	CC .. 06 02 ..	C04/C05.063.087.110
C14.030.085.009	104.9	134.1	30	CC .. 09 T3 ..	C04/C05.063.087.110
C14.030.067.006	115.9	153.1	30	CC .. 06 02 ..	C04/C05.080.116.140
C14.030.067.009	115.9	153.1	30	CC .. 09 T3 ..	C04/C05.080.116.140
C14.030.085.006	133.9	171.1	30	CC .. 06 02 ..	C04/C05.080.116.140
C14.030.085.009	133.9	171.1	30	CC .. 09 T3 ..	C04/C05.080.116.140
C14.726.003.009	153.9	191.1	30	CC .. 09 T3 ..	C04/C05.080.116.140

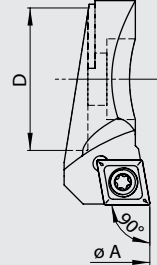

- für die Verwendung in Feinbohrköpfen der Serie C04, C05 und E90

- for use in fine boring heads from serie C04, C05 and E90



Bestell-Nr. / Order number	ø A min.	ø A max.	D	Wendeplatte / Insert	Feinbohrkopf / fine boring head
C15.011.024.006	23.9	31.1	11	CC .. 06 02 ..	C04/C05.020.024.045
C15.013.031.006	30.9	40.1	13	CC .. 06 02 ..	C04/C05.025.031.056
C15.017.040.006	39.9	51.1	17	CC .. 06 02 ..	C04/C05.032.040.066
C15.022.051.006	50.9	67.1	22	CC .. 06 02 ..	C04/C05.040.051.075
C15.030.067.009	66.9	87.1	30	CC .. 09 T3 ..	C04/C05.050.067.090
C15.030.067.009	86.9	116.1	30	CC .. 09 T3 ..	C04/C05.063.087.110
C15.030.067.009	115.9	153.1	30	CC .. 09 T3 ..	C04/C05.080.116.140

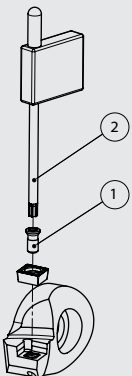
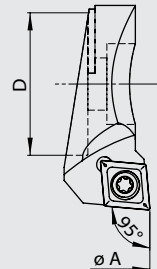

## Ersatzteile / Zubehör

## Spare parts / Accessories

C02/C14/C15

Für Wendeplattenhalter For insert holder	Bestell-Nr. / Order number	Bestell-Nr. / Order number
	Torx-Schraube / Torx screw ①	Torx-Schlüssel / Torx driver ②
C02.005.017.002	J00.254.020.004	J00.254.006.000
C14/C15.xxx.xxx.006	J00.254.025.006	J00.254.007.000
C14/C15.xxx.xxx.009	J00.254.040.009	J00.254.009.000

- für die Verwendung in Feinbohrköpfen der Serie C04, C05 und E90

- for use in fine boring heads from serie C04, C05 and E90

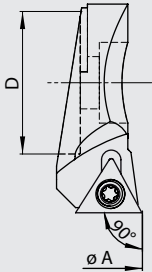

Bestell-Nr. / Order number	ø A min.	ø A max.	D	Wendeplatte / Insert	Feinbohrkopf / fine boring head
C17.011.024.T07	23.9	31.1	11	TP .. 07 01 ..	C04/C05.020.024.045
C17.011.030.T07	29.9	37.1	11	TP .. 07 01 ..	C04/C05.020.024.045
C17.013.031.T07	30.9	40.1	13	TP .. 07 01 ..	C04/C05.025.031.056
C17.013.038.T07	37.9	47.1	13	TP .. 07 01 ..	C04/C05.025.031.056
C17.017.040.T07	39.9	51.1	17	TP .. 07 01 ..	C04/C05.032.040.066
C17.017.048.T07	47.9	59.1	17	TP .. 07 01 ..	C04/C05.032.040.066
C17.022.051.T07	50.9	67.1	22	TP .. 07 01 ..	C04/C05.040.051.075
C17.022.065.T07	64.9	81.1	22	TP .. 07 01 ..	C04/C05.040.051.075
C17.030.067.T11	66.9	87.1	30	TP .. 11 02 ..	C04/C05.050.067.090
C17.030.085.T11	84.9	105.1	30	TP .. 11 02 ..	C04/C05.050.067.090
C17.030.067.T11	86.9	116.1	30	TP .. 11 02 ..	C04/C05.063.087.110
C17.030.085.T11	104.9	134.1	30	TP .. 11 02 ..	C04/C05.063.087.110
C17.030.067.T11	115.9	153.1	30	TP .. 11 02 ..	C04/C05.080.116.140
C17.030.085.T11	133.9	171.1	30	TP .. 11 02 ..	C04/C05.080.116.140
C17.726.003.T11	153.9	191.1	30	TP .. 11 02 ..	C04/C05.080.116.140



**Wendeplattenhalter 93°**

**Insert holders 93°**

- für die Verwendung in Feinbohrköpfen der Serie C04, C05 und E90

- for use in fine boring heads from serie C04, C05 and E90

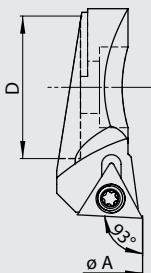

Bestell-Nr. / Order number	ø A min.	ø A max.	D	Wendeplatte / Insert	Feinbohrkopf / fine boring head
C16.011.024.T06	23.9	31.1	11	TB .. 06 01 ..	C04/C05.020.024.045
C16.013.031.T09	30.9	40.1	13	TP .. 09 02 ..	C04/C05.025.031.056
C16.017.040.T09	39.9	51.1	17	TP .. 09 02 ..	C04/C05.032.040.066
C16.022.051.T11	50.9	67.1	22	TP .. 11 03 ..	C04/C05.040.051.075
C16.030.067.T11	66.9	87.1	30	TP .. 11 03 ..	C04/C05.050.067.090
C16.030.085.T11	84.9	105.1	30	TP .. 11 03 ..	304/305.050.067.080
C16.030.067.T11	86.9	116.1	30	TP .. 11 03 ..	C04/C05.063.087.110
C16.030.085.T11	104.9	134.1	30	TP .. 11 03 ..	C04/C05.063.087.110
C16.030.067.T11	115.9	153.1	30	TP .. 11 03 ..	C04/C05.080.116.140
C16.030.085.T11	133.9	171.1	30	TP .. 11 03 ..	C04/C05.080.116.140



**Umkehradapter  
für Rückwärtsbearbeitung**

**Reversal adapter  
for reverse machining**

- für die Verwendung in Feinbohrköpfen der Serie C04 und C05
- damit können die Wendeplattenhalter der Serie C14 und C15 rückwärts montiert werden

- for use in fine boring heads from serie C04 und C05
- the insert holders from serie C14 and C15 will be fitted backwards on the adapter

Bestell-Nr. / Order number	ø A min.	ø A max.	D	L	X	Feinbohrkopf / fine boring head
C24.011.065.008	37	44	20	8.5	6.5	C04.020.024.045
C24.011.080.008	40	51	20	8.5	8.0	C04.020.024.045
C24.013.065.007	44	53	25	7.6	6.5	C04.025.031.056
C24.013.100.007	51	60	25	7.6	10.0	C04.025.031.056
C24.017.065.013	53	64	32	13.3	6.5	C04.032.040.066
C24.017.100.013	60	71	32	13.3	10.0	C04.032.040.066
C24.022.065.016	64	80	42	16.2	6.5	C04.040.051.075
C24.022.120.016	75	91	42	16.2	12.0	C04.040.051.075
C24.030.100.027	87	107	55	27.0	10.0	C04.050.067.090
C24.030.100.027	107	136	72	47.0	10.0	C04.063.087.110
C24.030.100.027	136	173	90	77.0	10.0	C04.080.116.140

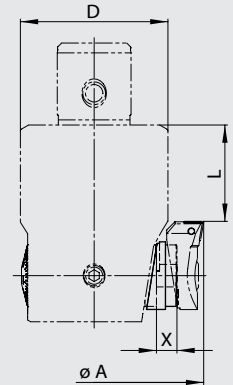

- Befestigungsschrauben werden mitgeliefert
- **Achtung: Linkslauf**

- fastening screws will be delivered with adapters
- **Caution: counterclockwise rotation**

**Einfahren  
Enter into the bore**

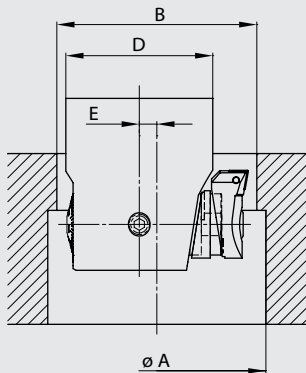

- Minstdurchmesser der Eintrittsbohrung

$$B = \frac{D + A}{2} - 1^*$$

- Mindestversatz zum Einfahren

$$E = \frac{A - B}{2} + 0.5^*$$

\*Sicherheitsabstand

**Rückwärtsbearbeitung  
Back boring**

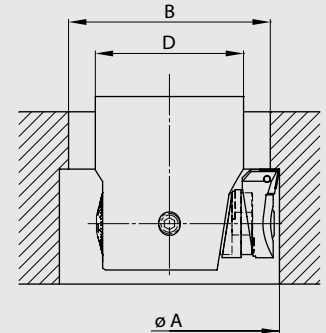

- minimum entry bore diameter

$$B = \frac{D + A}{2} - 1^*$$

- minimum off centre to enter into the bore

$$E = \frac{A - B}{2} + 0.5^*$$

\*safety distance

**Ersatzteile / Zubehör**

**Spare parts / Accessories**

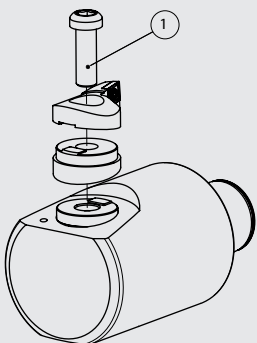

Für Umkehradapter For reversal adapter	Bestell-Nr. / Order number	Befestigungsschraube / Fastening screw ①
C24.011.065.008	J00.324.004.012	
C24.011.080.008	J00.324.004.013	
C24.013.065.007	J00.324.005.014	
C24.013.100.007	J00.324.005.016	
C24.017.065.013	J00.324.006.015	
C24.017.100.013	J00.324.006.020	
C24.022.065.016	J00.324.008.020	
C24.022.120.016	J00.324.008.025	
C24.030.100.027	J00.324.010.030	

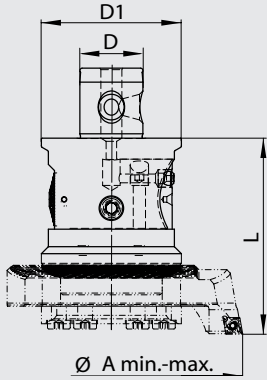

- Durchmessereinstellung mit geringstem Umkehrspiel
- Zustellgenauigkeit von 0.01mm im Durchmesser
- mit Innenkühlung

- diametrical adjustment with maximal reduced reversal backlash
- 0.01mm diametrical adjustment
- with inner coolant supply

Bestell-Nr. / Order number	ø A min.	ø A max.	WH	D	D1	L
C44.080.086.112	86	402	WH6/8	63/80	80	112

- Wendeplattenhalter der Serie C54 müssen separat bestellt werden

- insert holders from serie C54 must be ordered separately



Wendeplattenhalter inkl.  
Druckplatte und Abstützung

Insert holders incl.  
clamp plate and support block

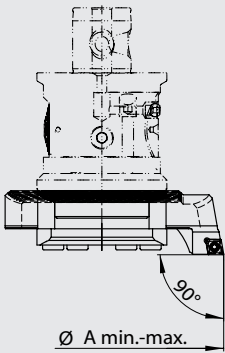

Bestell-Nr. / Order number	ø A min.	ø A max.	Wendeplatte / Insert
C54.086.138.009	86	138	CC.. 09 T3 ..
C54.086.138.012	86	138	CC.. 12 04 ..
C54.136.220.009	136	220	CC.. 09 T3 ..
C54.136.220.012	136	220	CC.. 12 04 ..
C54.188.302.009	188	302	CC.. 09 T3 ..
C54.242.402.009	242	402	CC.. 09 T3 ..



Ersatzteile / Zubehör

Spare parts / Accessories

Für Feinbohrkopf For fine boring head	Bestell-Nr. / Order number	Bestell-Nr. / Order number
	Klemmschraube / Clamping screw <sup>②</sup>	Befestigungsschraube / Fastening screw <sup>③</sup>
C44.080.086.112	J00.344.008.065	J00.344.008.044

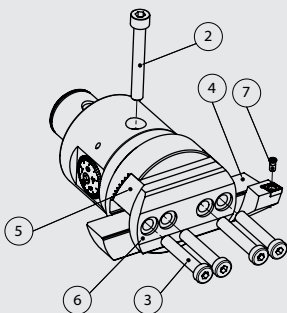

Für Wendeplatten- haltersatz	Bestell-Nr. / Order number	Bestell-Nr. / Order number	Bestell-Nr. / Order number	Bestell-Nr. / Order number	Bestell-Nr. / Order number
For insert holder set	Wendeplattenhal- ter / Insert holder <sup>④</sup>	Abstützung / Support block <sup>⑤</sup>	Druckplatte / Clamp plate <sup>⑥</sup>	Torx-Schraube / Torx screw <sup>⑦</sup>	Torx-Schlüssel / Torx driver
C54.086.138.009	J00.354.086.009	J00.345.020.086	J00.345.010.086	J00.254.040.009	J00.254.009.000
C54.086.138.012	J00.354.086.012	J00.345.020.086	J00.345.010.086	J00.254.050.010	J00.254.012.000
C54.136.220.009	J00.354.136.009	J00.345.020.136	J00.345.010.136	J00.254.040.009	J00.254.009.000
C54.136.220.012	J00.354.136.012	J00.345.020.136	J00.345.010.136	J00.254.050.010	J00.254.012.000
C54.188.302.009	J00.354.188.009	J00.345.020.136	J00.345.010.136	J00.254.040.009	J00.254.009.000
C54.242.402.009	J00.354.242.009	J00.345.020.136	J00.345.010.136	J00.254.040.009	J00.254.009.000

## Zwischneiderköpfe zum Einschrauben

## Twin cutter heads with thread connection

- mit Innenkühlung

- with inner coolant supply



Bestell-Nr. / Order number	ø A min.	ø A max.	d	L	Wendeplatten- halter / Insert holder
D00.020.024.041	23.5	30.5	20	41	D14.020.024.006 D24.020.024.006 D34.020.024.006 D37.020.024.006
D00.025.031.045	29.5	40.1	25	45	D14.025.031.006 D24.025.031.006 D34.025.031.006 D37.025.031.006
D00.032.040.051	39.5	50.5	32	51	D14.032.040.009 D24.032.040.009 D34.032.040.009 D37.032.040.009

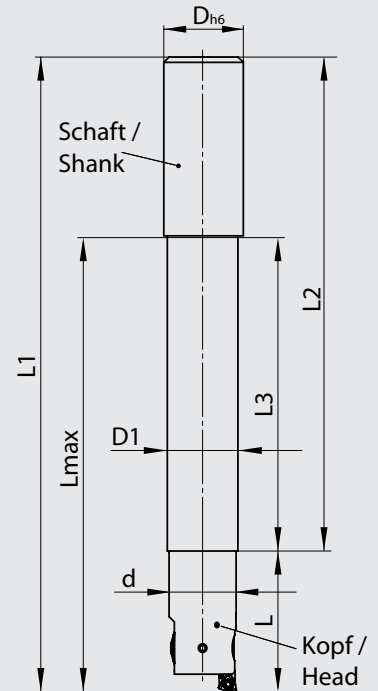

## Schwingungsgedämpfte Vollhartmetallschäfte

## Damped solid carbide shanks



- Produktivitätsgewinn dank der unterdrückten Schwingungen können die Schnittdaten beträchtlich erhöht werden
- Verbesserte Oberflächengüte
- Verbesserte Prozesssicherheit
- Verbesserte Spanabfuhr
- Reduzierte Kosten pro Bauteil
- Für Bohrungstiefen bis 12xD

- productivity improvement: thanks to reduced vibrations, the cutting conditions can be improved remarkable
- better surface quality
- improved process stability
- better chip evacuation
- reduced cost per part
- for boring length up to 12xD

Bestell-Nr. / Order number	D	D1	L max	L1	L2	L3	für Einschraubkopf / for screwable head
B84.025.023.170	25	23	146	211	170	105	C00/D00.020.024.041
B84.025.023.220	25	23	196	261	220	155	C00/D00.020.024.041
B84.025.023.265	25	23	241	306	265	200	C00/D00.020.024.041
B84.032.029.220	32	29	200	265	220	155	C00/D00.025.031.045
B84.032.029.260	32	29	240	305	260	195	C00/D00.025.031.045
B84.032.029.310	32	29	290	355	310	245	C00/D00.025.031.045
B84.032.032.217	32	32	203	268	217	152	C00/D00.032.040.051
B84.032.032.287	32	32	273	338	287	222	C00/D00.032.040.051
B84.032.032.357	32	32	343	408	357	292	C00/D00.032.040.051





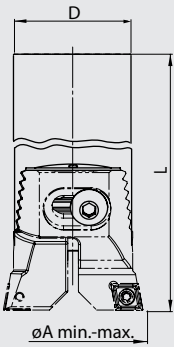

- mit Innenkühlung

- with inner coolant supply

Bestell-Nr. / Order number	ø A min.	ø A max.	Ø D/ System	L	Wendeplattenhalter / Insert holder
U20_Z20.K23.150	23.5	31.1	20	150	D14.020.024.006 (CC.. 06 02 ..)
U25_Z25.K23.170	29.5	40.1	25	170	D14.025.031.006 (CC.. 06 02 ..)

- Werkzeug in einem Spannzangen- oder Hydrodehnfutter spannen.
- **inklusive Wendeplattenhalter**

- Clamp tool in a collet or hydraulic chuck.
- **insert holder included**



ECO LINE

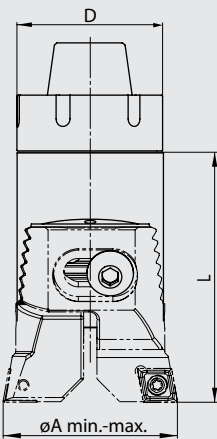

- mit Innenkühlung

- with inner coolant supply

Bestell-Nr. / Order number	ø A min.	ø A max.	Ø D/ System	L	Wendeplattenhalter / Insert holder
E25_Z32.K23.065	39.5	50.1	32 / ER25	65	D14.032.040.009 (CC.. 09 T3 ..)
E32_Z42.K23.075	49.5	67.1	42 / ER32	75	D14.039.051.009 (CC.. 09 T3 ..)
E40_Z55.K23.085	65.5	87.1	55 / ER40	85	D14.050.067.012 (CC.. 12 04 ..)

- Werkzeug in einem Spannzangenfutter spannen.
- **inklusive Wendeplattenhalter**

- Clamp tool in a collet chuck.
- **insert holder included**



ECO LINE

- mit Innenkühlung

- with inner coolant supply



Bestell-Nr. / Order number	ø A min.	ø A max.	WH	D	D1	L	Wendeplattenhalter / Insert holder
D04.020.024.045	23.5	30.5	WH1	20	20	45	D14.020.024.006 D24.020.024.006 D34.020.024.006 D37.020.024.006
D04.025.031.056	29.5	40.1	WH2	25	25	56	D14.025.031.006 D24.025.031.006 D34.025.031.006 D37.025.031.006
D04.032.040.066	39.5	50.5	WH3	32	32	66	D14.032.040.009 D24.032.040.009 D34.032.040.009 D37.032.040.009
D04.040.051.075	49.5	66.5	WH4	40	42	75	D14.039.051.009 D24.039.051.009 D34.039.051.009 D37.039.051.009
D04.050.067.090	65.5	87.5	WH5	50	55	90	D14.050.067.012/112 D24.050.067.012/112 D34.050.067.012 D37.050.067.012
D04.063.087.110	86.5	115.5	WH6	63	72	110	D14.064.087.012/116 D24.064.087.012/116 D34.064.087.012 D37.064.087.012
D04.080.115.140	114.5	153	WH8	80	94	140	D14.090.115.012/116 D24.090.115.116 D34.090.115.012 D37.090.115.012

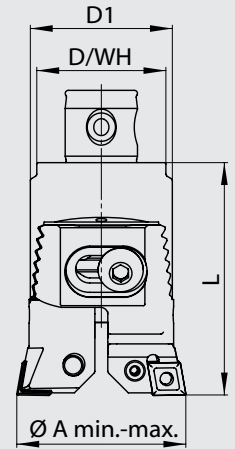

- Wendeplattenhalter müssen separat bestellt werden

- insert holders must be ordered separately

- für die Verwendung in Zweischneiderköpfen der Serie D04

- for use in twin cutter boring heads from serie D04



Bestell-Nr. / Order number	ø A min.	ø A max.	Wendeplatte / Insert	Zweischneiderkopf / twin cutter boring head
D14.020.024.006	23.5	30.5	CC ..06 02 ..	D04.020.024.045
D14.025.031.006	29.5	40.1	CC ..06 02 ..	D04.025.031.056
D14.032.040.009	39.5	50.5	CC ..09 T3 ..	D04.032.040.066
D14.039.051.009	49.5	66.5	CC ..09 T3 ..	D04.040.051.075
D14.050.067.012	65.5	87.5	CC ..12 04 ..	D04.050.067.090
D14.050.067.112	65.5	87.5	CN ..12 04 ..	D04.050.067.090
D14.064.087.012	86.5	115.5	CC ..12 04 ..	D04.063.087.110
D14.064.087.116	86.5	115.5	CN ..16 06 ..	D04.063.087.110
D14.090.115.012	114.5	153	CC ..12 04 ..	D04.080.115.140
D14.090.115.116	114.5	153	CN ..16 06 ..	D04.080.115.140

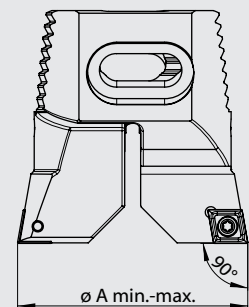

- Wendeplattenhalter werden paarweise geliefert

- insert holders will be supplied in pairs

- für die Verwendung in Zweischneiderköpfen der Serie D04
- mit der Synchrospindel können beide Wendeplattenhalter gleichzeitig symmetrisch eingestellt werden
- for use in twin cutter boring heads from serie D04
- with synchro spindle both insert holders can be adjusted synchronously and symmetrically

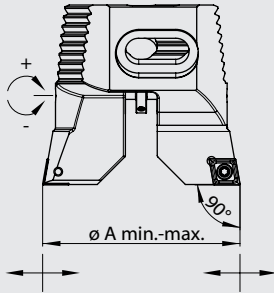

Bestell-Nr. / Order number	$\varnothing A$ min.	$\varnothing A$ max.	Wendeplatte / Insert	Zweischneiderkopf / twin cutter boring head
D34.020.024.006	23.5	30.5	CC ..06 02 ..	D04.020.024.045
D34.025.031.006	29.5	40.1	CC ..06 02 ..	D04.025.031.056
D34.032.040.009	39.5	50.5	CC ..09 T3 ..	D04.032.040.066
D34.039.051.009	49.5	66.5	CC ..09 T3 ..	D04.040.051.075
D34.050.067.012	65.5	87.5	CC ..12 04 ..	D04.050.067.090
D34.064.087.012	86.5	115.5	CC ..12 04 ..	D04.063.087.110
D34.090.115.012	114.5	153	CC ..12 04 ..	D04.080.115.140



- Wendeplattenhalter werden paarweise geliefert
- insert holders will be supplied in pairs

**Wendeplattenhalter 70°**

**Insert holders 70°**

- für die Verwendung in Zweischneiderköpfen der Serie D04
- for use in twin cutter boring heads from serie D04

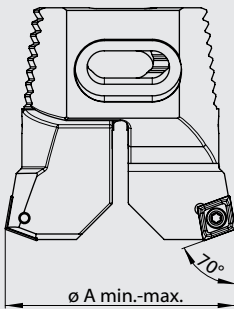

Bestell-Nr. / Order number	$\varnothing A$ min.	$\varnothing A$ max.	Wendeplatte / Insert	Zweischneiderkopf / twin cutter boring head
D24.020.024.006	23.5	30.5	CC ..06 02 ..	D04.020.024.045
D24.025.031.006	29.5	40.1	CC ..06 02 ..	D04.025.031.056
D24.032.040.009	39.5	50.5	CC ..09 T3 ..	D04.032.040.066
D24.039.051.009	49.5	66.5	CC ..09 T3 ..	D04.040.051.075
D24.050.067.012	65.5	87.5	CC ..12 04 ..	D04.050.067.090
D24.050.067.112	65.5	87.5	CN ..12 04 ..	D04.050.067.090
D24.064.087.012	86.5	115.5	CC ..12 04 ..	D04.063.087.110
D24.064.087.116	86.5	115.5	CN ..16 06 ..	D04.063.087.110
D24.090.115.116	114.5	153	CN ..16 06 ..	D04.080.115.140



- Wendeplattenhalter werden paarweise geliefert
- insert holders will be supplied in pairs

**Wendeplattenhalter 90° axial 0.4mm zurückgesetzt**

**Insert holders 90° axial 0.4mm staggered**

- für die Verwendung in Zweischneiderköpfen der Serie D04
- zur Schnittaufteilung bei grosser Spantiefe
- for use in twin cutter boring heads from serie D04
- for divided cut

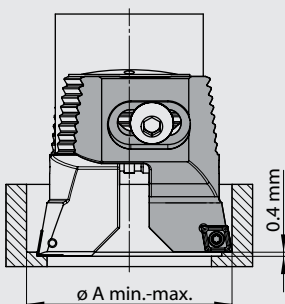

Bestell-Nr. / Order number	$\varnothing A$ min.	$\varnothing A$ max.	Wendeplatte / Insert	Zweischneiderkopf / twin cutter boring head
D37.020.024.006	23.5	30.5	CC ..06 02 ..	D04.020.024.045
D37.025.031.006	29.5	40.1	CC ..06 02 ..	D04.025.031.056
D37.032.040.009	39.5	50.5	CC ..09 T3 ..	D04.032.040.066
D37.039.051.009	49.5	66.5	CC ..09 T3 ..	D04.040.051.075
D37.050.067.012	65.5	87.5	CC ..12 04 ..	D04.050.067.090
D37.064.087.012	86.5	115.5	CC ..12 04 ..	D04.063.087.110
D37.090.115.012	114.5	153	CC ..12 04 ..	D04.080.115.140



- Wendeplattenhalter werden paarweise geliefert
- Ersatzteile siehe D14/D24/D37
- insert holders will be supplied in pairs
- spare parts see D14/D24/D37

## Ersatzteile / Zubehör

## Spare parts / Accessories

D04/D64

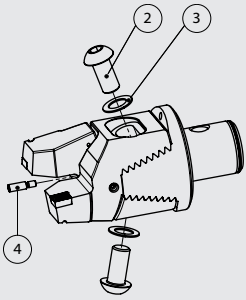

Für Zweischneiderkopf For twin cutter boring head	Bestell-Nr. / Order number	Bestell-Nr. / Order number	Bestell-Nr. / Order number
		② Befestigungsschraube / Fastening screw	③ Federring / Spring washer
			④ Anschlag / Stopper
D04.020.024.045	J00.404.004.008	J00.405.004.000	J00.406.030.012
D04/D64.025.031.056	J00.404.005.012	J00.405.005.000	J00.406.030.012
D04/D64.032.040.066	J00.404.006.016	J00.405.006.000	J00.406.030.012
D04/D64.040.051.0..	J00.404.008.020	J00.405.008.000	J00.406.040.020
D04/D64.050.067.0..	J00.404.010.025	J00.405.010.000	J00.406.040.020
D04./D64063.087.1..	J00.404.012.025	J00.405.012.000	J00.406.040.020
D04.080.115.140	J00.404.016.035	J00.405.016.000	J00.406.040.020

## Ersatzteile / Zubehör

## Spare parts / Accessories

D14/D24/D37/D74

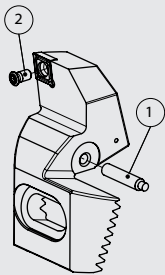

Für Wendeplattenhalter For insert holder	Bestell-Nr. / Order number	Bestell-Nr. / Order number	Bestell-Nr. / Order number
		① Einstellschraube / Adjustment screw	② Torx-Schraube / Torx screw
			③ Torx-Schlüssel / Torx driver
D14/D24/D37.020.024.006	J00.414.004.007	J00.254.025.006	J00.254.007.000
D14/D24/D37/D74.025.031.006	J00.414.004.010	J00.254.025.006	J00.254.007.000
D14/D24/D37/D74.032.040.009	J00.414.004.013	J00.254.040.009	J00.254.009.000
D14/D24/D37/D74.039.051.009	J00.414.006.014	J00.254.040.009	J00.254.009.000
D14/D24/D37/D74.050.067.xxx	J00.415.006.020	J00.254.050.010	J00.254.012.000
D14/D24/D37/D74.064.087.xxx	J00.415.006.030	J00.254.050.010	J00.254.012.000
D14/D24/D37.090.115.xxx	J00.415.006.040	J00.254.050.010	J00.254.012.000

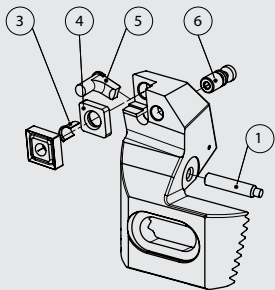

Für Wendeplattenhalter For insert holder	Bestell-Nr. / Order number	Bestell-Nr. / Order number	Bestell-Nr. / Order number	Bestell-Nr. / Order number
		③ Rohrstift / Hollow pin	④ Zwischenlage / Tip pad	⑤ Kniehebel / Lever
				⑥ Schraube zu Kniehebel / Lever screw
D14/D24.050.067.112	J00.416.012.000	J00.417.012.000	J00.418.012.000	J00.419.012.000
D14/D24.064.087.116	J00.416.016.000	J00.417.016.000	J00.418.016.000	J00.419.016.000
D14/D24.090.115.116	J00.416.016.000	J00.417.016.000	J00.418.016.000	J00.419.016.000

## Ersatzteile / Zubehör

## Spare parts / Accessories

D34

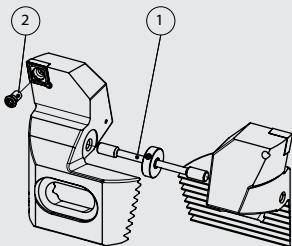

Für Wendeplattenhalter For insert holder	Bestell-Nr. / Order number	Bestell-Nr. / Order number	Bestell-Nr. / Order number
		① Einstellschraube / Adjustment screw	② Torx-Schraube / Torx screw
			③ Torx-Schlüssel / Torx driver
D34.020.024.006	J00.434.004.018	J00.254.025.006	J00.254.007.000
D34.025.031.006	J00.434.004.023	J00.254.025.006	J00.254.007.000
D34.032.040.009	J00.434.004.030	J00.254.040.009	J00.254.009.000
D34.039.051.009	J00.434.006.040	J00.254.040.009	J00.254.009.000
D34.050.067.012	J00.434.006.052	J00.254.050.010	J00.254.012.000
D34.064.087.012	J00.434.006.068	J00.254.050.010	J00.254.012.000
D34.090.115.012	J00.434.006.090	J00.254.050.010	J00.254.012.000

**Schrupp-/ Schlicht  
Zweischneiden Ausdrehkopf**

**Roughing-/Finishing  
twin cutter boring head**

D64

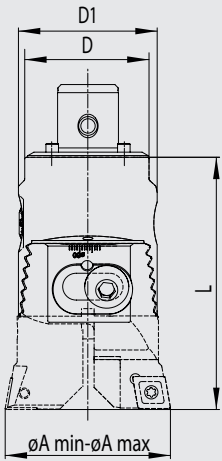

- Schruppen und Schlichten in einem Arbeitsgang
- Zustellgenauigkeit von 0.01mm im Durchmesser
- Schlichtschneide axial 0.4mm zurückgesetzt
- höchste Stabilität durch Kerbverzahnung
- mit Innenkühlung
- Roughing and finishing in one step
- Setting accuracy 0.01mm in diameter
- Fine boring cutting edge axial 0.4mm staggered
- highest stability because of the tooth profile
- with inner coolant supply

Order number	$\phi A$ min.	$\phi A$ max.	WH	D	D1	L	Insert holder
D64.025.031.056	29.5	40.1	WH2	25	25	56	D74.025.031.006
D64.032.040.066	39.5	50.5	WH3	32	32	66	D74.032.040.009
D64.040.051.082	49.5	66.5	WH4	40	42	82	D74.039.051.009
D64.050.067.100	65.5	87.5	WH5	50	55	100	D74.050.067.012
D64.063.087.125	86.5	115.5	WH6	63	72	125	D74.064.087.012



- Wendeplattenhalter müssen separat bestellt werden
- insert holders must be ordered separately

**Schrupp-/ Schlicht  
Wendeplattenhalterpaar 90°**

**Roughing-/Finishing  
insert holder pair 90°**

D74

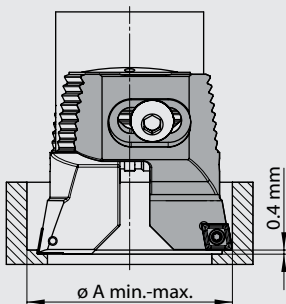

- für die Verwendung in Zweischneiderköpfen der Serie D64
- for use in twin cutter boring heads from serie D64

Order number	$\phi A$ min.	$\phi A$ max.	Insert	twin cutter boring head
D74.025.031.006	29.5	40.1	CC . .06 02 . .	D64.025.031.056
D74.032.040.009	39.5	50.5	CC . .09 T3 . .	D64.032.040.066
D74.039.051.009	49.5	66.5	CC . .09 T3 . .	D64.040.051.082
D74.050.067.012	65.5	87.5	CC . .12 04 . .	D64.050.067.100
D74.064.087.012	86.5	115.5	CC . .12 04 . .	D64.063.087.125



- Wendeplattenhalter werden paarweise geliefert
- insert holders will be supplied in pairs

**Ersatzteile / Zubehör**

**Spare parts / Accessories**

D44/D54

Für Zweischneiderkopf For twin cutter boring head	Bestell-Nr. / Order number	Bestell-Nr. / Order number	Bestell-Nr. / Order number	Bestell-Nr. / Order number
	Mitnehmer / Drive lug <sup>①</sup>	Befestigungsschraube / Fastening screw <sup>②</sup>		
D44.080.086.112	J00.102.064.000	J00.344.008.044		
Für Wendeplattenhaltersatz For insert holder set	Bestell-Nr. / Order number	Bestell-Nr. / Order number	Bestell-Nr. / Order number	Bestell-Nr. / Order number
	Wendeplattenhalter / Insert holder <sup>③</sup>	Druckplatte / Clamp plate <sup>④</sup>	Torx-Schraube / Torx screw <sup>⑤</sup>	Torx-Schlüssel / Torx driver
D54.086.138.009	J00.354.086.009	J00.345.010.086	J00.254.040.009	J00.254.009.000
D54.086.138.012	J00.354.086.012	J00.345.010.086	J00.254.050.010	J00.254.012.000
D54.136.220.009	J00.354.136.009	J00.345.010.136	J00.254.040.009	J00.254.009.000
D54.136.220.012	J00.354.136.012	J00.345.010.136	J00.254.050.010	J00.254.012.000
D54.188.302.009	J00.354.188.009	J00.345.010.136	J00.254.040.009	J00.254.009.000
D54.242.402.009	J00.354.242.009	J00.345.010.136	J00.254.040.009	J00.254.009.000

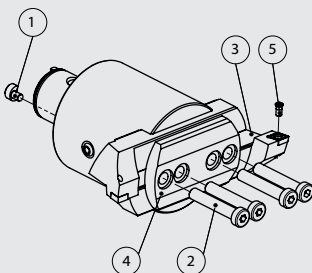

## Werkzeughalter zum Zapfendrehen

## Tool holders for pin turning

- Einfache, kostengünstige Ausführung
- Brücke wird auf einen Fräsdorn Ø32 gespannt
- Modular aufgebaut und verlängerbar für grosse Zapfenlängen
- mit innerer Kühlmittelzuführung

- simple and cost effective solution
- bridge is assembled on a milling arbor Ø32
- modular construction, extendable for long work pieces
- with inner coolant supply

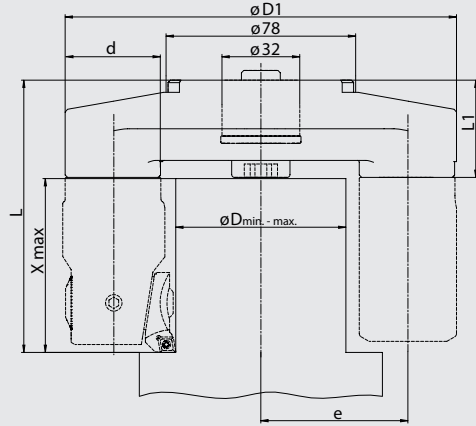

Bestell-Nr. / Order number	ø D min.	ø D max.	d	e	D1	L1	X max	L
E61.032.032.099	15.9	27.1	32	33.5	99	40	65.5	105.5
E61.032.032.110	26.9	38.1	32	39.0	110	40	65.5	105.5
E61.040.032.145	37.9	54.1	40	52.5	145	40	74.5	114.5
E61.040.032.161	53.9	70.1	40	60.5	161	40	74.5	114.5
E61.050.032.207	69.9	90.1	50	78.5	207	45	89.5	134.5
E61.050.032.227	89.9	110.1	50	88.5	227	45	89.5	134.5

- Gegengewicht und Spanschraube im Lieferumfang enthalten. Feinbohrkopf oder Zweischneiderkopf muss separat bestellt werden

- Counter weight and clamping screw included. Fine boring head or twin cutter must be ordered separately.

## Zapfenbearbeitung

## Pin turning

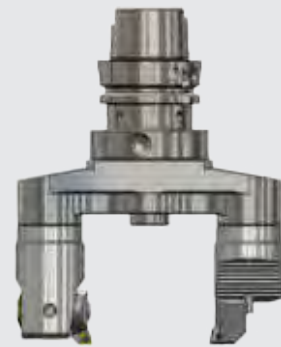
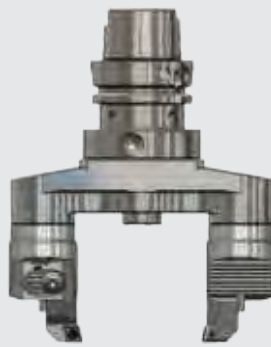

- **Achtung:** Spindel linksdrehend!  
Vc max. 450 m/min

- **Attention:** Counter clockwise spindle rotation  
Vc max. 450 m/min

**Werkzeugauswahl**

**Tool selection**



- Schlichten

- Finishing

Werkzeughalter / Toolholder	Ausdrehkopf / Boring head	Plattenhalter / Insert holder	ø D min.	ø D max.	Gegengewicht / Counter weight
E61.032.032.099	C04.032.040.066	C14.017.040.006	15.9	27.1	E95.032.032.057
E61.032.032.110	C04.032.040.066	C14.017.040.006	26.9	38.1	E95.032.032.057
E61.040.032.145	C04.040.051.075	C14.022.051.006	37.9	54.1	E95.040.042.072
E61.040.032.161	C04.040.051.075	C14.022.051.006	53.9	70.1	E95.040.042.072
E61.050.032.207	C04.050.067.090	C14.030.067.009	69.9	90.1	E95.050.055.081
E61.050.032.227	C04.050.067.090	C14.030.067.009	89.9	110.1	E95.050.055.081

**Werkzeugauswahl**

**Tool selection**



- Schruppen

- Roughing

Werkzeughalter / Toolholder	Schruppkopf / Roughing head	Plattenhalter / Insert holder	ø D min.	ø D max.
E61.032.032.099	D04.032.040.066	D14.032.040.009	15.9	27.1
E61.032.032.110	D04.032.040.066	D14.032.040.009	26.9	38.1
E61.040.032.145	D04.040.051.075	D14.039.051.009	37.9	54.1
E61.040.032.161	D04.040.051.075	D14.039.051.009	53.9	70.1
E61.050.032.207	D04.050.067.090	D14.050.067.012/112	69.9	90.1
E61.050.032.227	D04.050.067.090	D14.050.067.012/112	89.9	110.1

**Zweischneiderkopf ø86-402**

**Twin cutter boring head ø86-402**

**D44**

- mit Innenkühlung

- with inner coolant supply

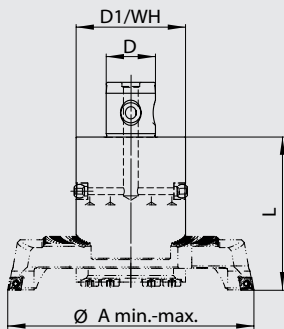

Bestell-Nr. / Order number	ø A min.	ø A max.	WH	D	D1	L
D44.080.086.112	86	402	WH6/8	36	80	112

- Wendeplattenhalter der Serie D54 müssen separat bestellt werden

- insert holders from serie D54 must be ordered separately



**Wendeplattenhalterpaare inkl. Druckplatte**

**Insert holder pairs incl. clamp plate**

**D54**

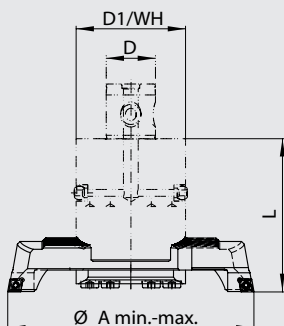

Bestell-Nr. / Order number	ø A min.	ø A max.	Wendeplatte / Insert
D54.086.138.009	86	138	CC.. 09 T3 ..
D54.086.138.012	86	138	CC.. 12 04 ..
D54.136.220.009	136	220	CC.. 09 T3 ..
D54.136.220.012	136	220	CC.. 12 04 ..
D54.188.302.009	188	302	CC.. 09 T3 ..
D54.242.402.009	242	402	CC.. 09 T3 ..



- DurchmesserEinstellung mit geringstem Umkehrspiel
- Zustellgenauigkeit von 0.01mm im Durchmesser
- mit Innenkühlung

- diameter setting with minimal reversal backlash
- 0.01mm diametrical adjustment
- with inner coolant supply



Bestell-Nr. / Order number	Ø D/ System	Ø A min.	Ø A max.	L	Feinbohraufsatz / Fine bore adapter
D32_F01.085.098	78 / D32	85.5	140.1	98	F01_WCA.B11.050 (CC.. 06 02 ..)
D32_F02.139.098	78 / D32	139.5	220.1	98	F02_WCA.B11.050 (CC.. 06 02 ..)
D32_F02.219.098	78 / D32	219.5	310.1	98	F02_WCA.B11.050 (CC.. 06 02 ..)
D40_F02.309.108	88 / D40	309.5	395.1	108	F02_WCA.B11.050 (CC.. 06 02 ..)
D40_F02.394.108	88 / D40	394.5	480.1	108	F02_WCA.B11.050 (CC.. 06 02 ..)
D60_F02.479.118	128 / D60	479.5	565.1	118	F02_WCA.B11.050 (CC.. 06 02 ..)
D60_F02.564.118	128 / D60	564.5	650.1	118	F02_WCA.B11.050 (CC.. 06 02 ..)

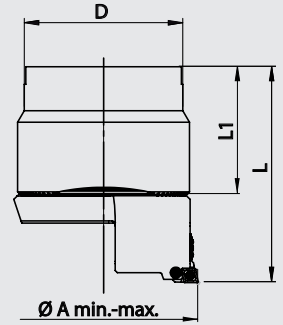

- Werkzeug in einer Fräsdorn- oder Messerkopfaufnahme spannen.
- **inklusive Feinbohraufsatz (F01/F02)**

- Clamp tool in a shell mill holder.
- **Fine boring adapter included (F01/ F02)**

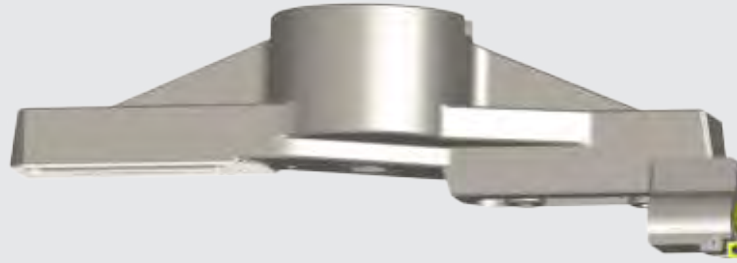

- mit Innenkühlung

- with inner coolant supply

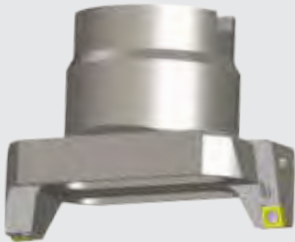

Bestell-Nr. / Order number	Ø D/ System	Ø A min.	Ø A max.	L	Wendeplattenhalter / Insert holder
D32_Z01.085.098	78 / D32	85.5	140.1	98	Z01_WCC.B11.050 (CC.. 12 04 ..)
D32_Z02.139.098	78 / D32	139.5	220.1	98	Z02_WCC.B11.050 (CC.. 12 04 ..)
D32_Z02.219.098	78 / D32	219.5	310.1	98	Z02_WCC.B11.050 (CC.. 12 04 ..)
D40_Z02.309.108	88 / D40	309.5	395.1	108	Z02_WCC.B11.050 (CC.. 12 04 ..)
D40_Z02.394.108	88 / D40	394.5	480.1	108	Z02_WCC.B11.050 (CC.. 12 04 ..)
D60_Z02.479.118	128 / D60	479.5	565.1	118	Z02_WCC.B11.050 (CC.. 12 04 ..)
D60_Z02.564.118	128 / D60	564.5	650.1	118	Z02_WCC.B11.050 (CC.. 12 04 ..)

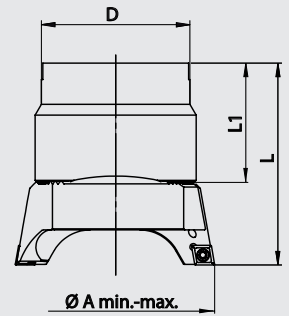

- Werkzeug in einer Fräsdorn- oder Messerkopfaufnahme spannen.
- **inklusive Wendeplattenhalter (Z01/Z02)**

- Clamp tool in a shell mill holder.
- **insert holder included (Z01/Z02)**

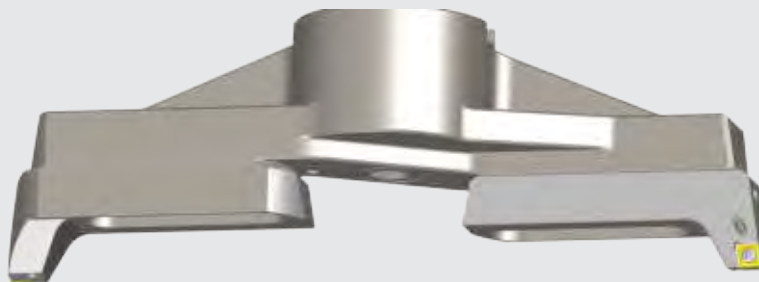



- für die Verwendung auf Aufnahme-  
dorn ø60 / ø129 DIN 6357
- Basis aus Aluminium
- fragen Sie uns an für optimierte Kom-  
plettlösungen

- for use on holding arbor ø60 / ø129
- basis made of aluminium
- please get in touch with us for  
customized solutions

Basis / Basis Bestell-Nr. / Order number	Schieber / Slider Bestell-Nr. / Order number	D	L	Ausrehdurchmesser / Boring diameter
E62.060.063.080	E64.000.310.048	630	128	650 – 1105
E62.060.108.080	E64.000.360.048	1080	128	1100 - 1655
E62.060.163.080	E64.000.360.048	1630	128	1650 – 2205

- Schieber müssen separat bestellt wer-  
den und werden paarweise geliefert
- sliders must be ordered separatly  
and will be supplied in pairs

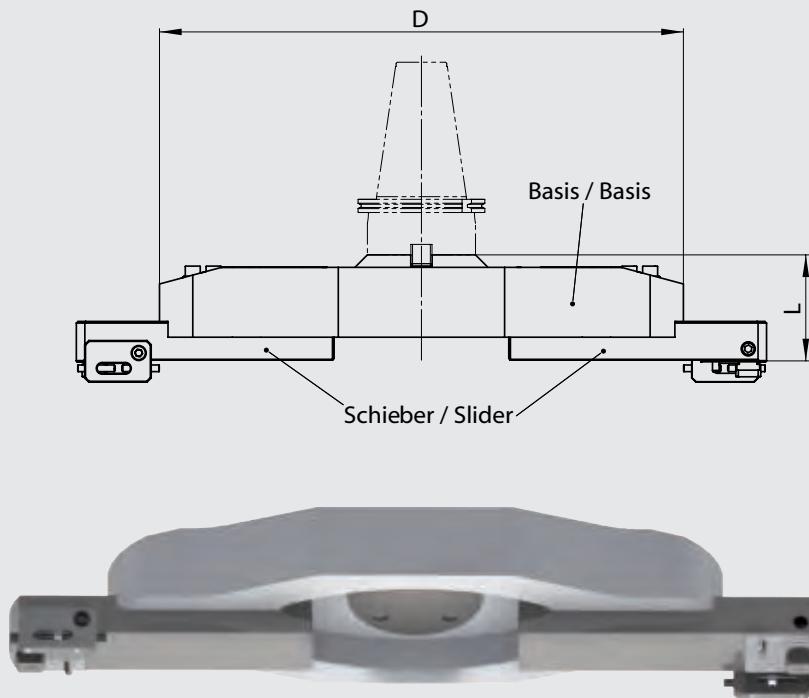

**Aufnahmedorn für  
Verlängerungskonsolen**

**Holding arbor for  
extension bridges**

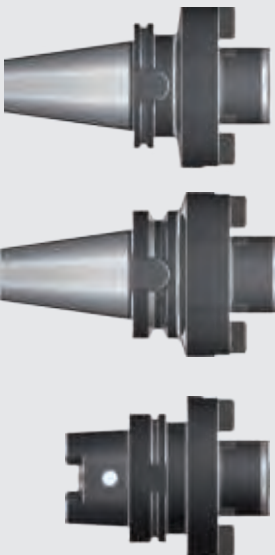

Bestell-Nr. / Order number	SK	d	A	L1	D
E58.450.060.070	SK 50	60	70	40	128

Bestell-Nr. / Order number	BT	d	A	L1	D
E58.550.060.080	BT 50	60	80	40	128

Bestell-Nr. / Order number	HSK-A	d	A	L1	D
E58.810.060.070	HSK-A 100	60	70	40	128

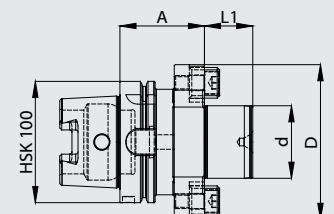
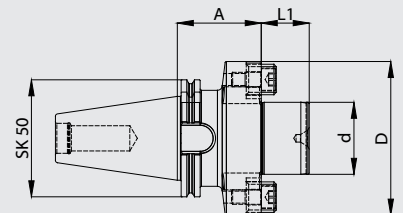



• ANSI B5.50

Bestell-Nr. / Order number	CAT	D	A
E04.340.130.069	40	130	69.1
E04.350.130.069	50	130	69.1

• DIN 69871 A/D

Bestell-Nr. / Order number	ISO	D	A
E14.440.130.069	40	130	69.1
E14.450.130.069	50	130	69.1

• MAS BT 403

Bestell-Nr. / Order number	BT	D	A
E34.540.130.077	40	130	77
E34.550.130.088	50	130	88

• DIN 69893 HSK A

Bestell-Nr. / Order number	HSK A	D	A
E44.806.130.075	63	130	77
E44.810.130.075	100	130	88

• Kühlmittelset muss separat bestellt werden J00.500.028.015

• ANSI B5.50

• DIN 69871 A/D

• MAS BT 403

• DIN 69893 HSK A

• cooling set must be ordered separately J00.500.028.015

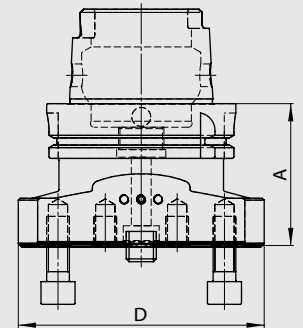
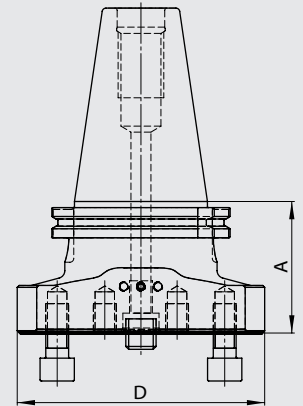

Bestell-Nr. / Order number	WH	D	D1	L
E54.090.130.055	WH8	80	130	55

• Kühlmittelset muss separat bestellt werden J00.500.028.015

• cooling set must be ordered separately J00.500.028.015

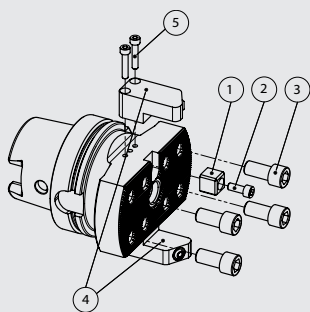
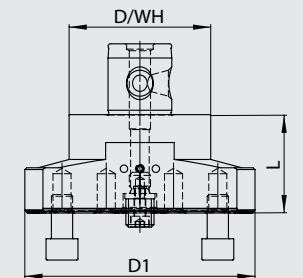

Ersatzteile / Zubehör

Spare parts / Accessories

E04/E14/E34/E44/E54

Für Konsole / For bridge adapter	Bestell-Nr. / Order number	Bestell-Nr. / Order number	Bestell-Nr. / Order number
	Mitnehmerstein / Drive lug (1)	Schraube / Screw (2)	Befestigungsschraube / Fastening screw (3)
E04-E54	J00.514.016.016	J00.515.006.015	J00.516.012.025
	Kühlmittelset / Cooling set (4)	Befestigungsschraube / Fastening screw (5)	
E04-E54	J00.500.028.015	J00.500.005.025	

• für die Verwendung auf Konsolen der Serien E04 bis E54

• for use on bridge adapters from series E04 to E54

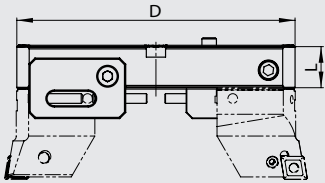

Bestell-Nr. / Order number	D	L	Ausdrehdurchmesser / Boring diameter
E60.130.130.030	130	30	150 – 205
E60.130.180.030	180	30	200 – 255
E60.130.230.035	230	35	250 – 305
E60.130.280.035	280	35	300 – 355
E60.130.330.040	330	40	350 – 405
E60.130.380.040	380	40	400 – 455
E60.130.430.040	430	40	450 – 505
E60.130.480.040	480	40	500 – 555
E60.130.530.050	530	50	550 – 605
E60.130.580.050	580	50	600 – 655



**Einstellplatte zum Überdrehen    Adjustment plate for pin turning**

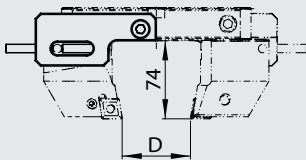

Einstellplatte / Adjustment plate Bestell-Nr. / Order number	Für Verlängerungskonsole / For extensions bridge	D
E00.561.080.012	E60.130.180.030	10 - 65
E00.561.080.012	E60.130.230.035	60 - 115
E00.561.080.012	E60.130.280.035	110 - 165
E00.561.080.012	E60.130.330.040	160 - 215
E00.561.080.012	E60.130.380.040	210 - 265
E00.561.080.012	E60.130.430.040	260 - 315
E00.561.080.012	E60.130.480.040	310 - 365
E00.561.080.012	E60.130.530.050	360 - 415
E00.561.080.012	E60.130.580.050	410 - 465



**Ersatzteile / Zubehör**

**Spare parts / Accessories**

**E60/E62/E64**

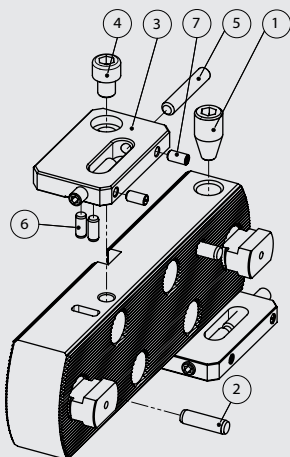

Für Verlängerungskonsole / Schieber	Bestell-Nr. / Order number	Bestell-Nr. / Order number	Bestell-Nr. / Order number	Bestell-Nr. / Order number
For extension bridge / Slider	Klemmschr. / Clamping screw ①	Stift / Pin ②	Feststellschraube / Tightening screw ⑦	
E60 / E64	J00.560.016.030	J00.560.008.028	J00.560.006.012	
Für Verlängerungskonsole / Schieber	Bestell-Nr. / Order number	Bestell-Nr. / Order number	Bestell-Nr. / Order number	Bestell-Nr. / Order number
For extension bridge / Slider	Einstellplatte / Adjustment plate ③	Schraube / Screw ④	Einstellschraube / Adjustment screw ⑤	Stift / Pin ⑥
E60.130.130/230.030	J00.560.080.012	J00.560.110.012	J00.560.008.045	J00.560.006.014
E60.130.180/280-580.xxx	J00.560.080.012	J00.560.110.018	J00.560.008.045	J00.560.006.014
E64.000.xxx.048	J00.560.080.012	J00.560.110.018	J00.560.008.045	J00.560.006.014
Für Basis For basis	Bestell-Nr. / Order number	Bestell-Nr. / Order number	Bestell-Nr. / Order number	Bestell-Nr. / Order number
	Zentrierbuchse / Centering sleeve	Schraube m. U-Scheibe / Screw w. washer	Unterlage / Mat	
E62.060.xxx.080	J00.562.018.012	J00.562.012.080	J00.562.138.005	

E70

Wendeplattenhalter 90°

Insert holder 90°



- für die Verwendung auf Verlängerungskonsolen der Serien E60 und E64

- for use on extension bridges from series E60 and E64

Bestell-Nr. / Order number	Wendeplatte / Insert
E70.070.009.075	CC .. 09 T3 ..
E70.070.012.075	CN .. 12 04 ..
E70.070.019.075	CN .. 19 06 ..

- Wendeplattenhalter werden paarweise geliefert

- insert holders will be supplied in pairs

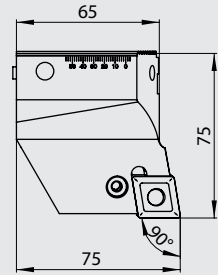

E75

Wendeplattenhalter 90° axial 1.0mm zurückgesetzt

Insert holder 90° axial 1.0mm staggered



- für die Verwendung auf Verlängerungskonsolen der Serien 560 und 564

- for use on extension bridges from series 560 and 564

Bestell-Nr. / Order number	Wendeplatte / Insert
E75.070.009.074	CC .. 09 T3 ..
E75.070.012.074	CN .. 12 04 ..
E75.070.019.074	CN .. 19 06 ..

- Wendeplattenhalter werden paarweise geliefert

- insert holders will be supplied in pairs



E80

Wendeplattenhalter 70°

Insert holder 70°



- für die Verwendung auf Verlängerungskonsolen der Serien E60 und E64

- for use on extension bridges from series E60 and E64

Bestell-Nr. / Order number	Wendeplatte / Insert
E80.070.019.075	CN .. 19 06 ..

- Wendeplattenhalter werden paarweise geliefert

- insert holders will be supplied in pairs

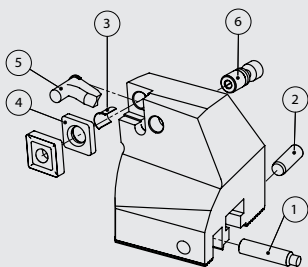
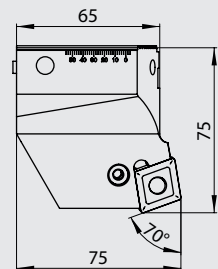

Ersatzteile / Zubehör

Spare parts / Accessories

E70/E75/E80

Für Wendeplattenhalter	Bestell-Nr. / Order number	Bestell-Nr. / Order number	Bestell-Nr. / Order number	Bestell-Nr. / Order number
For insert holder	Einstellschraube / Adjustment screw ①	Stift / Pin ②	Torx-Schraube / Torx screw	Torx-Schlüssel / Torx driver
E70/E75.070.009.075	J00.570.008.035	J00.570.008.024	J00.254.040.009	J00.254.009.000
E70/E75.070.012.075	J00.570.008.035	J00.570.008.024		
E70/E75.070.019.075	J00.570.008.035	J00.570.008.024		
E80.070.019.075	J00.570.008.035	J00.570.008.024		
Für Wendeplattenhalter	Bestell-Nr. / Order number	Bestell-Nr. / Order number	Bestell-Nr. / Order number	Bestell-Nr. / Order number
For insert holder	Rohrstift / Hollow pin ③	Zwischenlage / Tip pad ④	Kniehebel / Lever ⑤	Schraube zu Kniehebel / Lever screw ⑥
E70/E75.070.012.075	J00.416.012.000	J00.417.012.000	J00.418.012.000	J00.419.012.000
E70/E75.070.019.075	J00.416.019.000	J00.417.019.000	J00.418.019.000	J00.419.019.000
E80.070.019.075	J00.416.019.000	J00.417.019.000	J00.418.019.000	J00.419.019.000

**Feinbohrkopf**

**Fine boring head**

**E90**

- für die Verwendung auf Verlängerungskonsolen der Serien E60 und E64
- DurchmesserEinstellung mit geringstem Umkehrspiel
- Zustellgenauigkeit von 0.01mm resp. über Nonius 0.002mm im Durchmesser

- for use on extension bridges from series E60 and E64
- diametrical adjustment with maximal reduced reversal backlash
- 0.01mm diametrical adjustment resp. 0.002mm by nonius

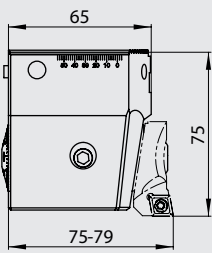

Bestell-Nr. / Order number	Wendeplattenhalter
E90.070.030.075	C14.030.067.006 C14.030.067.009

- Wendeplattenhalter müssen separat bestellt werden

- insert holder must be ordered separately

**Feinbohrkopf  
DIGITAL**

**Fine boring head  
DIGITAL**

**E91**

- für die Verwendung auf Verlängerungskonsolen der Serien 560 und 564
- Einstellgenauigkeit 0.001mm im Durchmesser
- direktes Wegmeßsystem (kein Umkehrspiel)
- keine Batterie und Auswerteelektronik im Werkzeug verbaut
- sehr einfache Bedienung
- digital und analog einsetzbar

- for use on extension bridges from series 560 and 564
- 0.001 accuracy in diameter
- direct measurement system (no backlash)
- no battery and electronic evaluation unit inside the tool
- very easy operation
- for digital and analog use

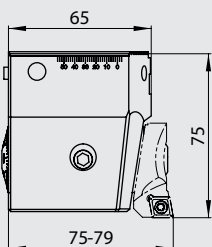

Bestell-Nr. / Order number	Wendeplattenhalter
E91.070.030.075	C14.030.067.006 C14.030.067.009

- Wendeplattenhalter müssen separat bestellt werden
- Anzeigeeinheit muss separat bestellt werden siehe Seite 6 (C09.028.024.077).

- insert holder must be ordered separately
- Display unit must be ordered separately see page 6 (C09.028.024.077).



**Gegengewicht**

**Counterweight**

**E94**

- zur Verwendung mit Feinbohrkopf der Serie E90/E91

- for use with fine boring head from serie E90/E91

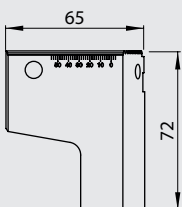

Bestell-Nr. / Order number
E94.070.065.072









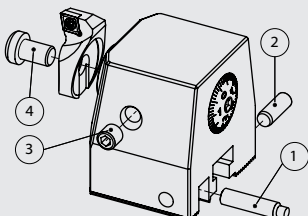











**Ersatzteile / Zubehör**

**Spare parts / Accessories**

**E90/E91**







Für Feinbohrkopf For fine boring head	Bestell-Nr. / Order number	Bestell-Nr. / Order number	Bestell-Nr. / Order number	Bestell-Nr. / Order number
	Einstellschraube / Adjustment screw	Stift / Pin	Klemmschraube / Clamping screw	Befestigungsschraube / Fastening screw
E90/E91.070.030.075	J00.570.008.035	J00.570.008.024	J00.590.010.020	J00.314.010.016

Bestell-Nummer	Wendeplatte	Schneidstoff	Technische Informationen	Materialen	v [m/min]	f [mm/Z]	
Order number	Insert	Cutting mat.	Technical information	Materials	v [m/min]	f [mm/r]	
H00.600.050.022	WCMT 020102 	CTU 	<b>Cermet-Wendeplatte</b> (Titan-Carbid / Titan-Nitrid) für Feinbohrarbeiten mit hoher Schnittgeschwindigkeit und gleichmässigem Aufmass.	Stahl Grauguss Aluminium	50–300 50–300 bis 800	0.04 bis 0.10	
			Titanium carbide / titanium nitride ( <b>Cermet</b> ) for fine bore machining with high cutting speed and regular cutting depth.	Steel Cast Iron Aluminium	50–300 50–300 to 800	0.04 to 0.10	
H00.600.060.022	WCGT 020102 	HUP 	Unbeschichtete <b>Hartmetall-Wendeplatte</b> , allseitig geschliffen mit grossem Spanwinkel für Feinbohrarbeiten. Die Wendeplatte eignet sich insbesondere bei kleinem Aufmass und langen Bohrungen.	Stahl Stahl rostfrei Grauguss Aluminium	50–250 30–200 50–300 bis 800	0.04 bis 0.10	
			Uncoated Carbide insert, ground all around with large rake angle for fine bore cutting. The insert is particularly good for small cutting depth in deep bores.	Steel Stainless steel Cast iron Aluminium	50–250 30–200 50–300 to 800	0.04 to 0.10	
H00.600.070.022	WCGT 020102 	SFH 	Mehrfach <b>beschichtete superfeinstkorn Hartmetall-Wendeplatte</b> zur Bearbeitung von harten und gehärteten Werkstoffen <b>bis 62 HRC</b> . Die Wendeplatte eignet sich hervorragend für Feinbohrarbeiten in gehärtetem Stahl als Alternative zum K-Schleifen.	Stahl weich	bis 300	0.04	
H00.600.070.024	WCGT 020104 			Stahl HRC 45	80–250	bis	
				Stahl HRC 50	80–200	0.20	
				Stahl HRC 55	50–150		
				Stahl HRC 60	30–100		
				Stahl HRC 62	20– 60		
			Repeat <b>coated extremely fine grain carbide</b> insert for machining of hard and hardened steels up to <b>62 HRC</b> . Very suitable for fine boring of precision bores in hardened steel as an alternative to Jig-grinding.	Steel soft Steel HRC 45 Steel HRC 50 Steel HRC 55 Steel HRC 60 Steel HRC 62	bis 300 80–250 80–200 50–150 30–100 20– 60	0.04 to 0.20	
H00.600.200.062	CCMT 060202 	CTU 	<b>Cermet-Wendeplatte</b> (Titan-Carbid / Titan-Nitrid) für niedrige bis hohe Schnittgeschwindigkeiten beim Schlichten mit gleichbleibendem Aufmass. Auch für leichte Schrupparbeiten einsetzbar. Bester Widerstand gegen Verschleiss und Schneidekantendeformation. Geeignet für Feinbohrarbeiten mit normalem Aufmass von 0.25 mm im Durchmesser.	Stahl	50–300	0.08	
H00.600.200.064	CCMT 060204 			Stahl rostfrei	30–250	bis	
H00.600.200.092	CCMT 09T302 			Grauguss	50–300	0.15	
H00.600.200.094	CCMT 09T304 			Aluminium	bis 800		
H00.600.200.098	CCMT 09T308 			Buntmetall	bis 500		
H00.600.200.128	CCMT 120408 						
			Titanium carbide / titanium nitride ( <b>Cermet</b> ) for finishing with low to high cutting speeds with regular cutting depth. Also for light roughing. High resistance to wear and tip deformation. Suitable for fine boring with normal cutting depths from 0.25 mm in bored diameter.	Steel Stainless steel Cast iron Aluminium Copper alloys	50–300 30–250 50–300 to 800 to 500	0.08 to 0.15	
H00.600.850.062	CCGT 060202L 	ICH 	Hochwiderstandsfähig gegen Brüche durch die besondere Zusammensetzung des Basismaterial plus der speziellen TiCN-Beschichtung. Sehr hohe mechanische Stabilität und Verschleissbeständigkeit. Sehr gut geeignet für unterbrochenen Schnitt.	Stahl weich	bis 300	0.04	
H00.600.850.064	CCGT 060204L 			Stahl HRC 45	80–250	to	
H00.600.850.094	CCGT 09T304L 			Stahl HRC 50	80–200	0.20	
				Stahl HRC 55	50–150		
				Stahl rostfrei	30–200		
				Grauguss	50–300		
			Excellent toughness and wear resistance due to the special composition of the base material plus the special TiCN coating. Very suitable for interrupted cuts	Steel soft Steel HRC 45 Steel HRC 50 Steel HRC 55 Stainless steel Cast iron	bis 300 80–250 80–200 50–150 30–200 50–300	0.04 to 0.20	

● schruppen / roughing

◐ schruppen und schlichten / roughing and finishing

○ schlichten / finishing

Bestell-Nummer	Wendeplatte	Schneidstoff	Technische Informationen	Materialen	v [m/min]	f [mm/Z]
Order number	Insert	Cutting mat.	Technical information	Materials	v [m/min]	f [mm/r]
H00.600.300.062	CCGT 060202L ○	CTG 	Allseitig <b>geschliffene, hochpositive Cermet-Wendeplatte</b> (Titan-Carbid / Titan-Nitrid), für alle Feinbohrarbeiten. Die Wendeplatte eignet sich insbesondere bei kleinem Aufmass und langen Bohrungen. Durch den grossen Spanwinkel sind die Druck- und Schnittkräfte sehr gering.	Stahl	50–300	0.06
H00.600.300.064	CCGT 060204L ○			Stahl rostfrei	30–250	bis
H00.600.300.092	CCGT 09T302L ○			Grauguss	50–250	0.12
H00.600.300.094	CCGT 09T304L ○			Aluminium	bis 800	
				Buntmetall	bis 500	
<b>HIT</b>			All ground, <b>Cermet</b> insert with highly positive rake angle for all fine bore machining. Very suitable for deep bores with small cutting depth. Low cutting and pressing forces due to large rake angle.	Steel	50–300	0.06
				Stainless steel	30–250	to
				Cast iron	50–250	0.12
				Aluminium	to 800	
				Copper alloys	to 500	
H00.600.800.062	CCGT 060202L ○	SFH 	Mehrfach <b>beschichtete superfeinstkorn Hartmetall-Wendeplatte</b> zur Bearbeitung von harten und gehärteten Werkstoffen <b>bis 62 HRC</b> . Die Wendeplatte eignet sich hervorragend für Feinbohrarbeiten in gehärtetem Stahl als Alternative zum K-Schleifen.	Stahl weich	bis 300	0.04
H00.600.800.064	CCGT 060204L ○			Stahl HRC 45	80–250	bis
H00.600.800.092	CCGT 09T302L ○			Stahl HRC 50	80–200	0.20
H00.600.800.094	CCGT 09T304L ○			Stahl HRC 55	50–150	
				Stahl HRC 60	30–100	
				Stahl HRC 62	20– 60	
<b>HIT HRC+</b>			Repeat <b>coated extremely fine grain carbide</b> insert for machining of hard and hardened steels up to <b>62 HRC</b> . Very suitable for fine boring of precision bores in hardened steel as an alternative to Jig-grinding.	Steel soft	bis 300	0.04
				Steel HRC 45	80–250	to
				Steel HRC 50	80–200	0.20
				Steel HRC 55	50–150	
				Steel HRC 60	30–100	
				Steel HRC 62	20– 60	
H00.600.400.064	CCMT 060204 ●	HBH  	Mehrfach <b>beschichtete Hartmetall-Wendeplatte</b> mit hoher Verschleissfestigkeit und grossem Widerstand gegen plastische Verformung. Generell geeignet für die Stahlbearbeitung mit mittleren bis hohen Schnittgeschwindigkeiten.	Stahl	20–280	0.10
H00.600.400.094	CCMT 09T304 ●			Stahl rostfrei	30–250	bis
H00.600.400.098	CCMT 09T308 ●			Grauguss	50–250	0.40
H00.600.401.128	CCMT 1204.08 ●			Sphäroguss	50–180	
H00.600.400.128	CNMG 120408 ●			Aluminium	bis 800	
H00.600.400.168	CNMG 160608 ●			Buntmetall	bis 500	
H00.600.400.169	CNMG 160612 ●					
H00.600.400.198	CNMG 190612 ●					
H00.600.400.199	CNMG 190616 ●					
			Repeat <b>coated carbide</b> insert with high wear and plastic deformation resistance. Generally used for machining of ferrous steels with middle to high cutting speeds.	Steel	20–280	0.10
				Stainless steel	30–250	to
				Cast iron	50–250	0.40
				Spheroidal cast iron	50–180	
				Aluminium	to 800	
				Copper alloys	to 500	
H00.600.500.128	CNMM 120408 ●	HBZ 	Mehrfach <b>beschichtete Hartmetall-Wendeplatte</b> mit höchster Zähigkeit und Stabilität der Schneidekante. Geeignet für Stahlbearbeitung durch die positive Schneidegeometrie auch bei unterbrochenem Schnitt.	Stahl	50–300	0.10
H00.600.500.168	CNMM 160608 ●			Stahl rostfrei	30–250	bis
H00.600.500.169	CNMM 160612 ●			Grauguss	50–300	0.60
H00.600.500.198	CNMM 190612 ●			Sphäroguss	50–200	
H00.600.500.199	CNMM 190616 ●			Aluminium	bis 800	
				Buntmetall	bis 500	
			Repeat <b>coated carbide</b> insert, very tough with high stability cutting edge. Suitable for machining of ferrous steels also with interrupted cut due to its positive cutting geometry.	Steel	50–300	0.10
				Stainless steel	30–250	to
				Cast iron	50–300	0.60
				Spheroidal cast iron	50–200	
				Aluminium	to 800	
				Copper alloys	to 500	

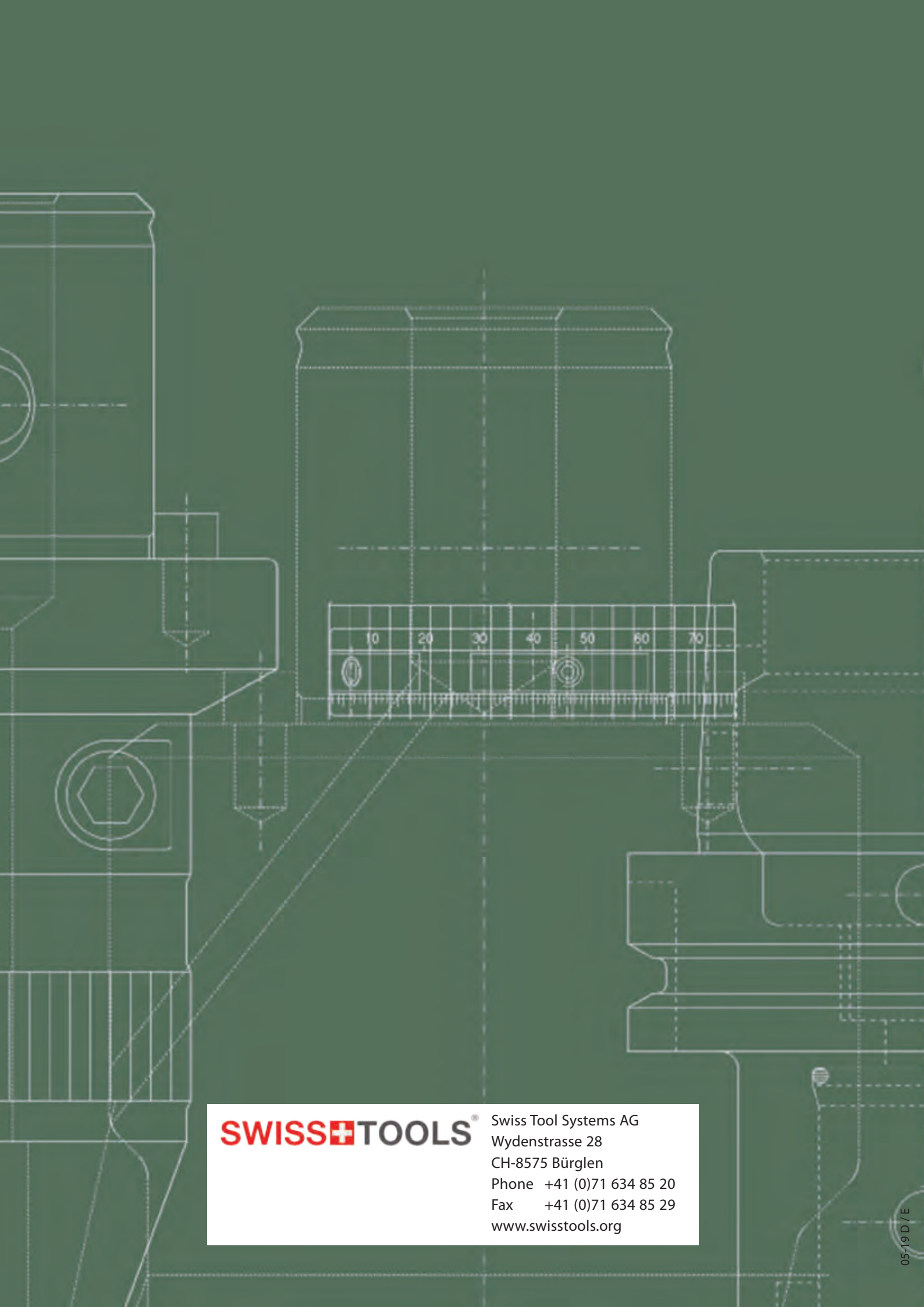

**SWISS+TOOLS**<sup>®</sup> Swiss Tool Systems AG  
Wydenstrasse 28  
CH-8575 Bürglen  
Phone +41 (0)71 634 85 20  
Fax +41 (0)71 634 85 29  
[www.swisstools.org](http://www.swisstools.org)