



SWISS  TOOLS[®]

S w i s s
BORE
1905

by **SWISS  TOOLS**

Seite / page 16

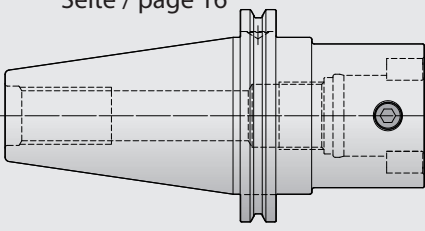

Seite / page 16

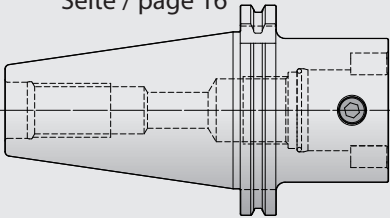

Seite / page 17

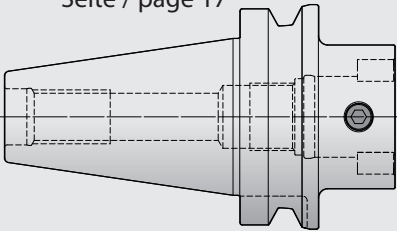

Seite / page 15

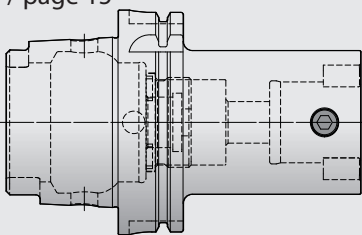

Seite / page 15

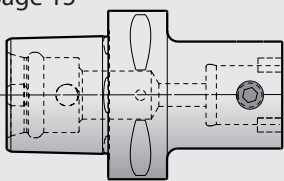

Seite / page 51

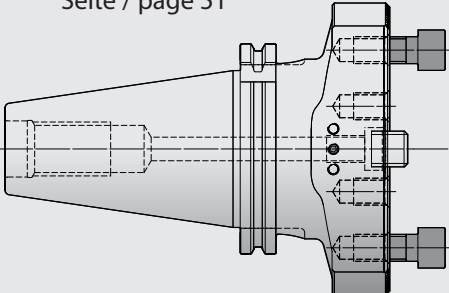

Seite / page 51

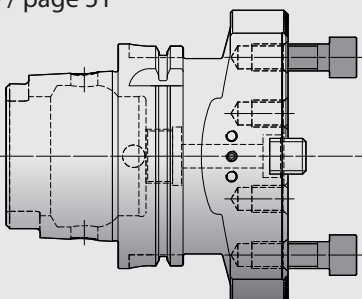

Seite / page 20

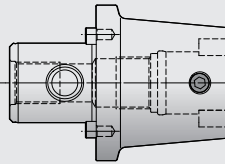

Seite / page 19

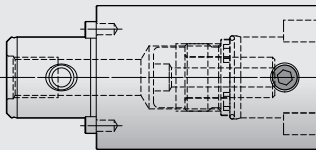

Seite / page 51

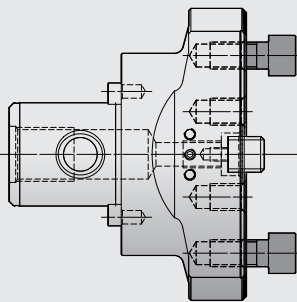

Seite / page 49

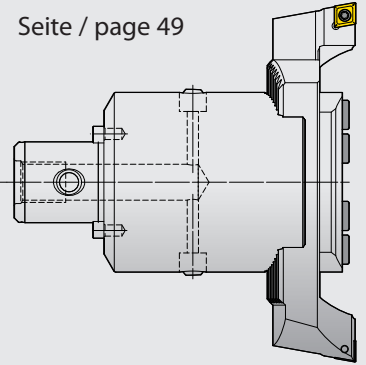

Seite / page 41+43

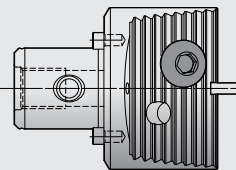

Seite / page 52

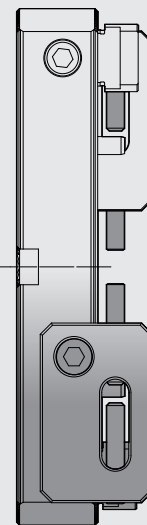

Seite / page 53

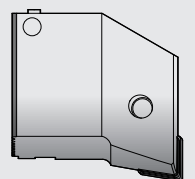
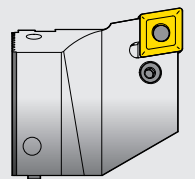

Seite / page 40

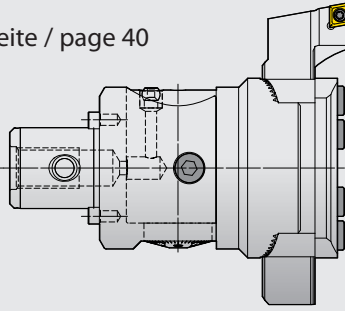

Seite / page 58-59



Seite / page 6

NEW
DIGITAL

Seite / page 33-39

NEW
DIGITAL

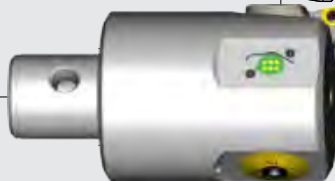

Seite / page 43-45

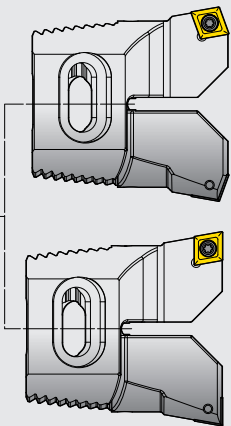

Seite / page 26

Seite / page 26

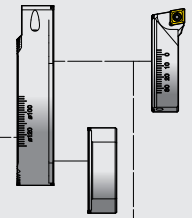
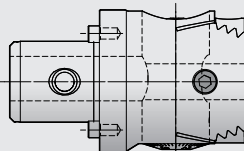

Seite / page 30

Seite /
page 32



Seite / page 21-25



Seite / page 29

Seite / page 28

Seite / page 27



Seite / page 54



NEW
DIGITAL

NEW
DIGITAL



Seite / page 28

Seite /
page 31

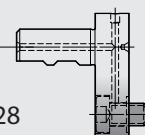

Seite / page 28



Seite / page 56

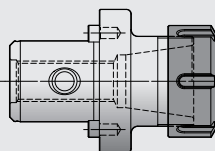

Seite / page 57

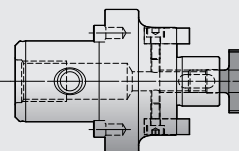

Seite / page 56

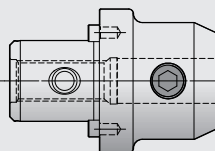

Seite / page 57

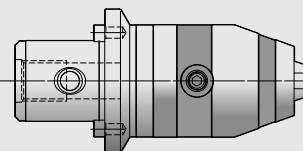

THE WORLD'S SMALLEST

digital fine boring head from \varnothing 0.3 mm

NEW



WELTNEUHEIT

kleinster digitaler Feinbohrkopf ab \varnothing 0.3 mm

SWISS DAMPING TECHNOLOGY

schwingungsgedämpfte Lösungen
damped boring solutions

NEW



PSC DIGITALE FEINBOHRWERKZEUGE DIGITAL FINE BORING HEADS

- ein Display für alle Feinbohrköpfe
Ø 0.3 mm - 2205.0 mm
 - Anzeige umkehrbar (Links-/ Rechtshänder)
 - mm/inch umschaltbar
 - Standard AAA Batterie zur Stromversorgung
 - Display wird über Magnetkraft am Werkzeug gehalten
 - Einstellgenauigkeit 0.001mm im Durchmesser
 - direktes Wegmeßsystem (kein Umkehrspiel)
 - keine Batterie und Auswerteelektronik im Werkzeug verbaut
 - sehr einfache Bedienung
 - digital und analog einsetzbar
- one display for all fine boring heads diameter 0.3 mm – 2205 mm
 - display reversible (LH/RH)
 - mm/inch switchable
 - standard AAA battery required
 - display unit will docked with magnetic forces at the tool
 - 0.001 accuracy in diameter
 - direct measurement system (no backlash)
 - no battery and electronic evaluation unit inside the tool
 - very easy operation
 - for digital and analog use



ECO LINE

MODULAR BORING SYSTEM Ø 9.75 - 650.1 mm
don't think about the interface you already have it

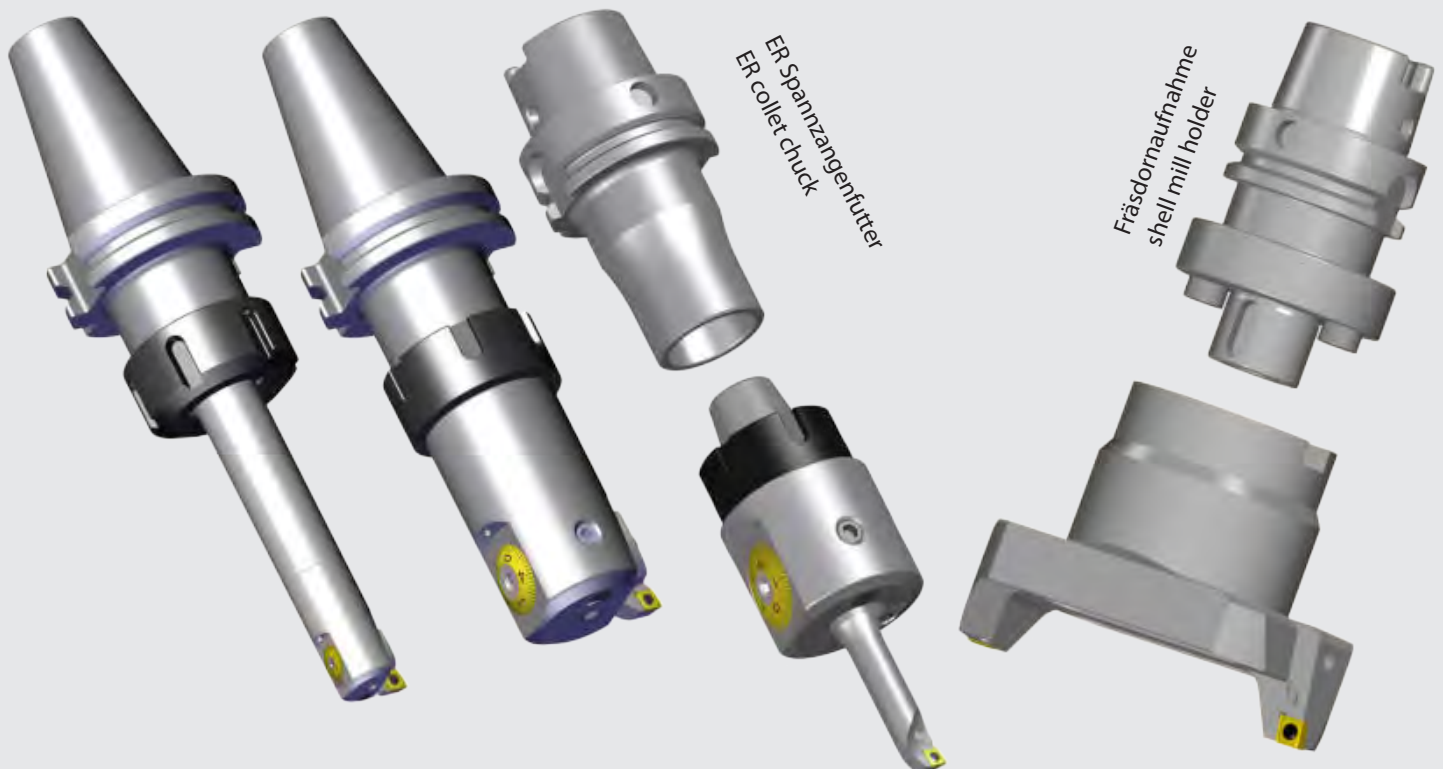

**DIGITALE
Anzeigeeinheit**

**DIGITAL
display unit**

NEW

- ein Display für alle Feinbohrköpfe Ø 0.3 mm - 2205.0 mm
 - Anzeige umkehrbar (Links-/ Rechtshänder)
 - mm/inch umschaltbar
 - Standard AAA Batterie zur Stromversorgung
 - Display wird über Magnetkraft am Werkzeug gehalten
 - Einstellgenauigkeit 0.001mm im Durchmesser
 - direktes Wegmeßsystem (kein Umkehrspiel)
 - keine Batterie und Auswerteelektronik im Werkzeug verbaut
 - sehr einfache Bedienung
 - digital und analog einsetzbar
- one display for all fine boring heads diameter 0.3 mm – 2205 mm
 - display reversible (LH/RH)
 - mm/inch switchable
 - standard AAA battery required
 - display unit will be docked with magnetic forces at the tool
 - 0.001 accuracy in diameter
 - direct measurement system (no backlash)
 - no battery and electronic evaluation unit inside the tool
 - very easy operation
 - for digital and analog use



Bestell-Nr. / Order number	Anzeigeeinheit/ display unit
309.028.024.077	

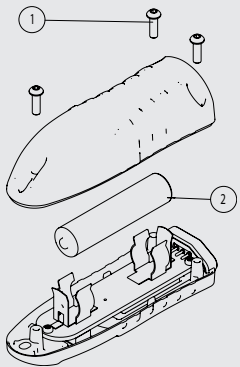

Ersatzteile / Zubehör

Spare parts / Accessories

309

Für Anzeigeeinheit For display unit	Bestell-Nr. / Order number	Bestell-Nr. / Order number	Bestell-Nr. / Order number
	Torx-Schraube / Torx screw (1)	Batterie / Battery (2)	Torx-Schlüssel / Torx driver
309.028.024.077	900.309.022.008	900.308.011.045	900.254.006.000



Ø 150.0 mm - 2205.0 mm Seite / page 47



Ø 3.0 mm - 88.1 mm Seite / page 22



Ø 23.9 mm - 203.1 mm Seite / page 32

**Digital einstellbarer
Feinbohr-Kurzklemmhalter**

**Digital adjustable
fine boring module**

KKH

NEW



- Einfaches Handling
- Präzise Masskorrektur
- Direktes Weg-Messsystem
- Wartungsfrei

- Easy handling
- Precise adjustment
- No backlash
- Maintenance-free

Bestell-Nr. / Order number	f	Ø D min.	L	L	Wendeplatte / Insert
KKH.WCA.016.045	16	25	45	55	CC.. 06 02 ..

- Feinverstellung digitale Anzeige 0.001mm
- Radialer Verstellweg: min. 0,4 mm
- Axiale Längenverstellung: 1.5 mm über Keilelement
- Drehzahl: max.10.000 U/min
- Innenkühlung direkt auf die Werkzeug-schneide

- Fine adjustment digital display 0.001mm
- Radial adjustment: min. 0.4 mm
- Axial length adjustment: 1.5 mm
- Speed: max.10.000 rpm
- Internal cooling directly on the tool cutting edge

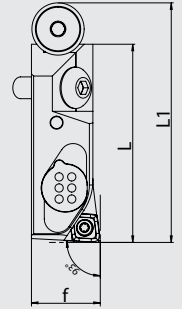
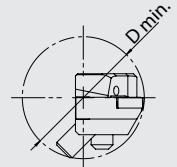

**Anzeigeeinheit für
Feinbohr-Kurzklemmhalter**

**Display unit for
fine boring module**

GH1

Bestell-Nr. / Order number	Anzeigeeinheit/ display unit
GH1.DA2.BGK.077	



- Anzeige umkehrbar (Links-/ Rechtshänder)
- mm/inch umschaltbar
- Standard AAA Batterie zur Stromversorgung
- Display wird über Magnetkraft am Werkzeug gehalten
- Einstellgenauigkeit 0.001mm im Durchmesser
- direktes Wegmeßsystem (kein Umkehrspiel)
- keine Batterie und Auswerteelektronik im Werkzeug verbaut
- sehr einfache Bedienung
- digital und analog einsetzbar

- display reversible (LH/RH)
- mm/inch switchable
- standard AAA battery required
- display unit will docked with magnetic forces at the tool
- 0.001 accuracy in diameter
- direct measurement system (no backlash)
- no battery and electronic evaluation unit inside the tool
- very easy operation
- for digital and analog use

• erweiterbar von $\varnothing 3$ bis $\varnothing 88.1$ • can be upgraded from $\varnothing 3$ up to $\varnothing 88.1$

Bestell-Nr. / Order number	D	$\varnothing A$ min.	$\varnothing A$ max.	L	L1	Ausdrehkopf / Fine boring head
ST6 modular						
785.064.010.030	64	9.75	30.1	45	-	204.064.025.045
DIN 69893 HSK 63 A						
785.163.010.030	55	9.75	30.1	95	70	208.806.055.095
DIN 69871 AD 40						
785.415.010.030	55	9.75	30.1	90	80	208.440.055.090
MAS BT 40						
786.412.010.030	55	9.75	30.1	90	80	208.540.055.090

Inhalt	Content
1 Koffer / Case	
1 Ausdrehkopf / Fine boring head	
1 Ausdrehstahl / Boring bar	$\varnothing 9.75-15.1$ 254.010.006.075
1 Ausdrehstahl / Boring bar	$\varnothing 14.75-20.1$ 254.015.006.090
1 Ausdrehstahl / Boring bar	$\varnothing 19.75-25.1$ 254.020.006.105
1 Ausdrehstahl / Boring bar	$\varnothing 24.75-30.1$ 254.025.006.115
1 Inbusschlüssel / Allen wrench	SW5
1 Torx-Schlüssel / Torx driver	T7

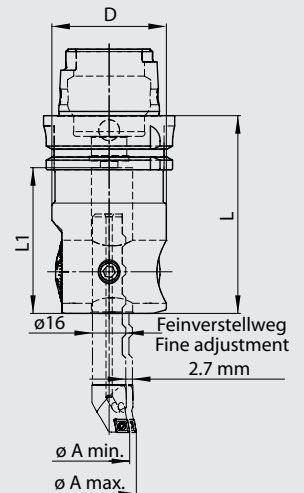
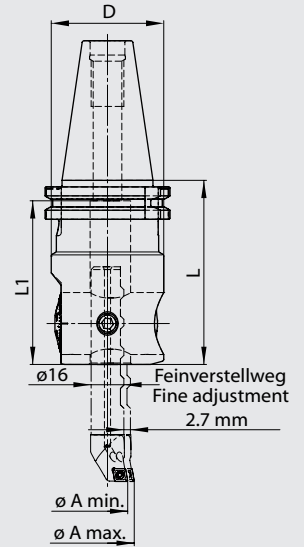
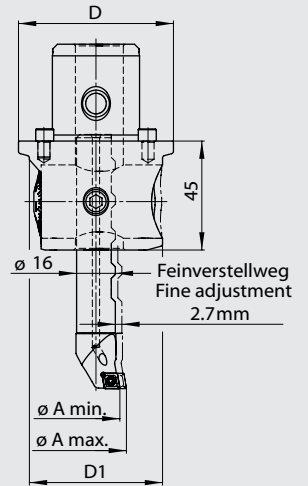
• erweiterbar von $\varnothing 3$ bis $\varnothing 88.1$ • can be upgraded from $\varnothing 3$ up to $\varnothing 88.1$

Bestell-Nr. / Order number	D	$\varnothing A$ min.	$\varnothing A$ max.	L	L1	Ausdrehkopf / Fine boring head
ST6 modular						
789.064.010.030	64	9.75	30.1	45	75	206.064.025.045
DIN 69893 HSK 63 A						
789.163.010.030	55	9.75	30.1	95	70	209.806.055.095
DIN 69871 AD 40						
789.415.010.030	55	9.75	30.1	90	80	209.440.055.090
MAS BT 40						
789.412.010.030	55	9.75	30.1	90	80	209.540.055.090

Inhalt	Content
1 Koffer / Case	
1 Ausdrehkopf / Fine boring head	
1 Ausdrehstahl / Boring bar	$\varnothing 9.75-15.1$ 254.010.006.075
1 Ausdrehstahl / Boring bar	$\varnothing 14.75-20.1$ 254.015.006.090
1 Ausdrehstahl / Boring bar	$\varnothing 19.75-25.1$ 254.020.006.105
1 Ausdrehstahl / Boring bar	$\varnothing 24.75-30.1$ 254.025.006.115
1 Inbusschlüssel / Allen wrench	SW5
1 Torx-Schlüssel / Torx driver	T7
1 Digitale Anzeigeeinheit / dig. display	309.028.024.077



• erweiterbar von ø3 bis ø88.1

• can be upgraded from ø3 up to ø88.1

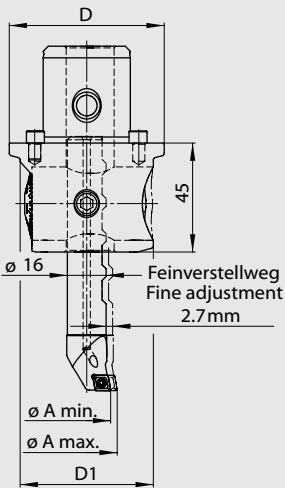

Bestell-Nr. / Order number	D	ø A min.	ø A max.	L	L1	Ausdrehkopf / Fine boring head
ST6 modular						
786.064.010.088	64	9.75	88.1	50	-	204.064.025.045
DIN 69893 HSK 63 A						
785.163.010.088	55	9.75	88.1	95	70	208.806.055.095
DIN 69871 AD 40						
785.415.010.088	55	9.75	88.1	90	80	208.440.055.090
MAS BT 40						
786.412.010.088	55	9.75	88.1	90	80	208.540.055.090

Inhalt	Content
1 Koffer / Case	
1 Ausdrehkopf / Fine boring head	
1 Ausdrehstahl / Boring bar	ø9.75-15.1 254.010.006.075
1 Ausdrehstahl / Boring bar	ø14.75-20.1 254.015.006.090
1 Ausdrehstahl / Boring bar	ø19.75-25.1 254.020.006.105
1 Ausdrehstahl / Boring bar	ø24.75-30.1 254.025.006.115
1 Schaft / shank	ø29.75-48.1 256.030.048.115
1 Schaft / shank	ø47.75-88.1 256.048.088.115
1 Wendeplattenhalter / Insert holder	ø29.75-48.1 256.030.006.012
1 Wendeplattenhalter / Insert holder	ø47.75-88.1 256.048.006.014
1 Inbusschlüssel / Allen wrench	SW4
1 Inbusschlüssel / Allen wrench	SW5
1 Torx-Schlüssel / Torx driver	T7

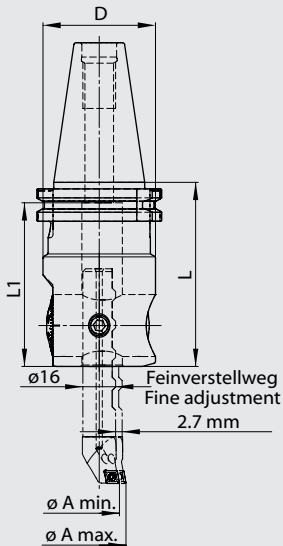

**Ausdrehset ø9.75-88.1
DIGITAL**

**Fine boring set ø9.75-88.1
DIGITAL**

• erweiterbar von ø3 bis ø88.1

• can be upgraded from ø3 up to ø88.1

Bestell-Nr. / Order number	D	ø A min.	ø A max.	L	L1	Ausdrehkopf / Fine boring head
ST6 modular						
789.064.010.088	64	9.75	88.1	50	-	206.064.025.045
DIN 69893 HSK 63 A						
789.163.010.088	55	9.75	88.1	95	70	209.806.055.095
DIN 69871 AD 40						
789.415.010.088	55	9.75	88.1	90	80	209.440.055.090
MAS BT 40						
789.412.010.088	55	9.75	88.1	90	80	209.540.055.090

Inhalt	Content
1 Koffer / Case	
1 Ausdrehkopf / Fine boring head	
1 Ausdrehstahl / Boring bar	ø9.75-15.1 254.010.006.075
1 Ausdrehstahl / Boring bar	ø14.75-20.1 254.015.006.090
1 Ausdrehstahl / Boring bar	ø19.75-25.1 254.020.006.105
1 Ausdrehstahl / Boring bar	ø24.75-30.1 254.025.006.115
1 Schaft / shank	ø29.75-48.1 256.030.048.115
1 Schaft / shank	ø47.75-88.1 256.048.088.115
1 Wendeplattenhalter / Insert holder	ø29.75-48.1 256.030.006.012
1 Wendeplattenhalter / Insert holder	ø47.75-88.1 256.048.006.014
1 Inbusschlüssel / Allen wrench	SW4
1 Inbusschlüssel / Allen wrench	SW5
1 Torx-Schlüssel / Torx driver	T7
1 Digitale Anzeigeeinheit / dig. display	309.028.024.077

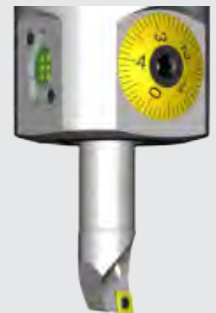

Ausdrehset $\varnothing 9.75-164$ Fine boring set $\varnothing 9.75-164$

• erweiterbar von $\varnothing 3$ bis $\varnothing 320$

• can be upgraded from $\varnothing 3$ up to $\varnothing 320$



ST6

Bestell-Nr. / Order number	ST	D	D1	$\varnothing A$ min.	$\varnothing A$ max.	Ausdrehkopf / Fine boring head
788.064.010.164	ST6	64	63	9.75	164	210.064.025.065

ST6

DIN 69871 AD 40

Bestell-Nr. / Order number	ISO	L	A	$\varnothing A$ min.	$\varnothing A$ max.	Ausdrehkopf / Fine boring head
788.415.010.164	40	90	120	9.75	164	210.440.063.090

DIN 69871 AD 40

MAS BT 40

Bestell-Nr. / Order number	BT	L	A	$\varnothing A$ min.	$\varnothing A$ max.	Ausdrehkopf / Fine boring head
788.412.010.164	40	90	120	9.75	164	210.540.063.090

MAS BT 40

DIN 69893 HSK A 63

Bestell-Nr. / Order number	HSK	L	A	$\varnothing A$ min.	$\varnothing A$ max.	Ausdrehkopf / Fine boring head
788.063.010.164	63	95	125	9.75	164	210.806.063.095

DIN 69893 HSK A 63

Inhalt	Content	
1 Koffer / Case		
1 Ausdrehkopf / Fine boring head		
1 Ausdrehstahl / Boring bar	$\varnothing 9.75-15.1$	254.010.006.075
1 Ausdrehstahl / Boring bar	$\varnothing 14.75-20.1$	254.015.006.090
1 Ausdrehstahl / Boring bar	$\varnothing 19.75-25.1$	254.020.006.105
1 Ausdrehstahl / Boring bar	$\varnothing 24.75-30.1$	254.025.006.115
1 Schaft / shank	$\varnothing 29.75-48.1$	256.030.048.115
1 Schaft / shank	$\varnothing 47.75-88.1$	256.048.088.115
1 Brücke / Bridge	$\varnothing 86.0-164.0$	212.086.164.080
1 Wendeplattenhalter / Insert holder	$\varnothing 29.75-48.1$	256.030.006.012
1 Wendeplattenhalter / Insert holder	$\varnothing 47.75-88.1$	256.048.006.014
1 Inbusschlüssel / Allen wrench	SW4	
1 Inbusschlüssel / Allen wrench	SW5	
1 Torx-Schlüssel / Torx driver	T7	

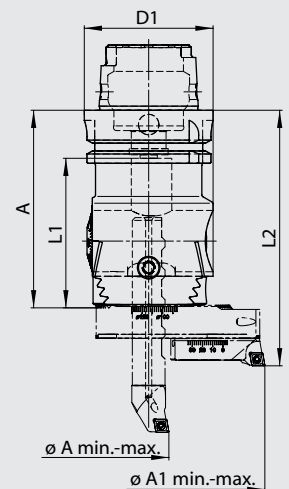
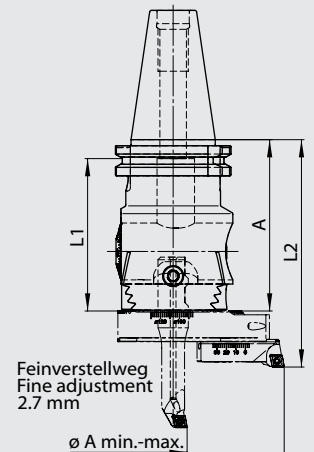
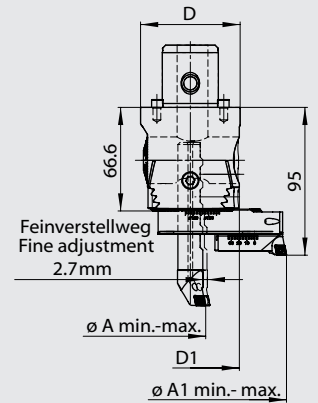

Ausdrehset ø9.75-101.1

Fine boring set Ø9.75-101.1

- Zustellgenauigkeit 0.01mm resp. über Nonius 0.002mm im Durchmesser
- erweiterbar von ø3 bis ø152.1

- 0.01mm diametrical adjustment resp. 0.002mm by nonius
- can be upgraded from ø3 up to ø152.1

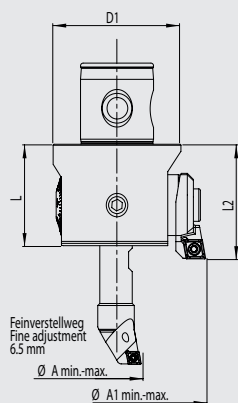

Bestell-Nr. / Order number	D1	L	L2	ø A min.	ø A max.	Ausdrehkopf / Fine boring head
783.064.010.101	63	50.5	57	9.75	101.1	205.064.025.050

Inhalt	Content	
1 Koffer / Case		
1 Ausdrehkopf / Fine boring head	ST6	205.064.025.050
1 Ausdrehstahl / Boring Bar	ø 9.75 - 20.1	254.010.006.075
1 Ausdrehstahl / Boring Bar	ø 19.75 - 30.1	254.020.006.105
1 Schaft / Shank	ø 29.75 - 48.1	256.030.048.115
1 Schaft / Shank	ø 47.75 - 88.1	256.048.088.115
1 Wendeplattenhalter / Insert holder	ø 29.75 - 48.1	256.030.006.012
1 Wendeplattenhalter / Insert holder	ø 47.75 - 88.1	256.048.006.014
1 Wendeplattenhalter / Insert holder CC . . 09 T3 . .	ø 87.75 - 101.1 (Ø114.1)	314.726.001.009
1 Kühlmittleinsatz / Coolant plug		900.805.000.032
2 Torx-Schlüssel / Torx driver	T7 / T15	900.254.007.000 900.254.009.000
1 Inbusschlüsselset / Allen wrench set	SW 1.5 - 8	900.892.015.080

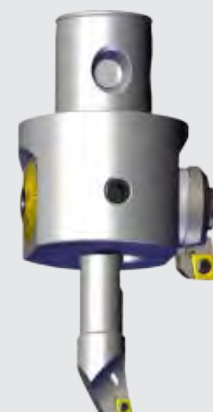

Zubehör	Accessories	
Wendeplattenhalter / Insert holder CC . . 09 T3 . .	ø 105.75 - 119.0 (ø 132.0)	314.726.002.009
Wendeplattenhalter / Insert holder CC . . 09 T3 . .	ø 125.75 - 139.0 (ø 152.0)	314.726.003.009
Distanzstück / Adapter F = 6.5 mm	ø 114.0 / ø 132.0 / ø 152.0	900.803.001.006

Ausdrehset ø86-302

Fine boring set ø86-302

- erweiterbar bis ø402

- can be upgraded up to ø402

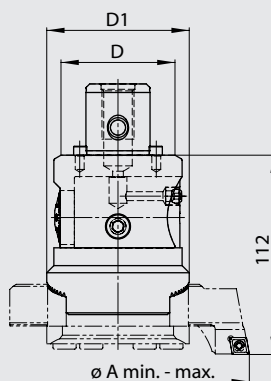

Bestell-Nr. / Order number	ST	D	D1	ø A min.	ø A max.	Feinbohrkopf / Fine boring head
790.064.086.302	ST6+	64	80	86	302	344.064.086.112

Inhalt	Content	
1 Koffer / Case		
1 Feinbohrkopf / Fine boring head		344.064.086.112
1 Wendeplattenhalter / Insert holder	ø86-138	900.354.086.009
1 Wendeplattenhalter / Insert holder	ø136-220	900.354.136.009
1 Wendeplattenhalter / Insert holder	ø188-302	900.354.188.009
1 Abstützung / Support block		900.354.020.086
1 Abstützung / Support block		900.354.020.136
1 Druckplatte / Clamp plate		900.354.010.086
1 Druckplatte / Clamp plate		900.354.010.136
10 Wendeplatten / Inserts	CC . . 09 T3 . .	800.600.200.094
1 Inbusschlüssel / Allen wrench	SW5	
1 Torx-Schlüssel / Torx driver	T15	



Ausdrehset $\varnothing 39.9-70.1$ Fine boring set $\varnothing 39.9-70.1$

- Schnittstelle ER25 DIN6499
- Zustellgenauigkeit 0.01mm im Durchmesser
- für Wendepplatten CC . . 06 02 . .
- erweiterbar bis $\varnothing 100.1$

- connection ER25 DIN 6499
- 0.01mm diametrical adjustment
- for inserts CC . . 06 02 . .
- can be upgraded to $\varnothing 100.1$



Bestell-Nr. / Order number	D	L	L1	L2	$\varnothing A$ min.	$\varnothing A$ max.	Ausdrehkopf / Fine boring head
784.001.040.070	39	25.5	8	20.5	39.9	70.1	598.040.070.009

Inhalt	Content	
1 Grundkörper / Base unit	ER25	726.025.000.000
1 Feinbohrkopf / Fine boring head	$\varnothing 39.9 - 70.1$	598.040.070.009
4 Schraube / Screw	M4 x 25	900.726.004.025
1 Torxschlüssel / Torx wrench	T7	900.254.007.000
1 Inbusschlüsselset / Allen key set	1.5-8.0	900.892.015.080

Zubehör	Accessories	
Erweiterung / Extension	$\varnothing 69.9 - 100.1$	215.070.100.000

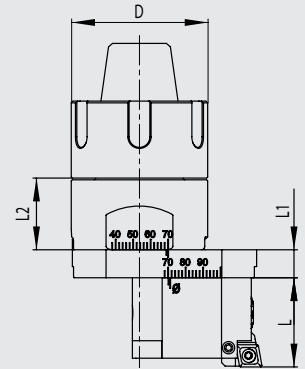
Ausdrehset $\varnothing 9.75-30.1$ Fine boring set $\varnothing 9.75-30.1$

- erweiterbar von $\varnothing 3$ bis $\varnothing 88.1$
- Schnittstelle ER32 DIN6499

- can be upgraded from $\varnothing 3$ up to $\varnothing 88.1$
- connection ER32 DIN 6499

Bestell-Nr. / Order number	D	$\varnothing A$ min.	$\varnothing A$ max.	L	Ausdrehkopf / Fine boring head
SMART ER32					
785.032.010.030	55	9.75	30.1	60	211.032.055.060

Inhalt	Content	
1 Koffer / Case		
1 Ausdrehkopf / Fine boring head		211.032.055.060
1 Ausdrehstahl / Boring bar	$\varnothing 9.75-15.1$	254.010.006.075
1 Ausdrehstahl / Boring bar	$\varnothing 14.75-20.1$	254.015.006.090
1 Ausdrehstahl / Boring bar	$\varnothing 19.75-25.1$	254.020.006.105
1 Ausdrehstahl / Boring bar	$\varnothing 24.75-30.1$	254.025.006.115
1 Inbusschlüssel / Allen wrench	SW5	
1 Torx-Schlüssel / Torx driver	T7	

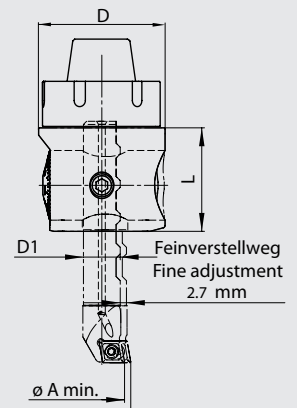

Ausdrehset ø9.75-101.1

Fine boring set Ø9.75-101.1

- Schnittstelle ER40 DIN6499
- Zustellgenauigkeit 0.01mm resp. über Nonius 0.002mm im Durchmesser
- erweiterbar von ø3 bis ø152.1

- connection ER40 DIN 6499
- 0.01mm diametrical adjustment resp. 0.002mm by nonius
- can be upgraded from ø3 up to ø152.1

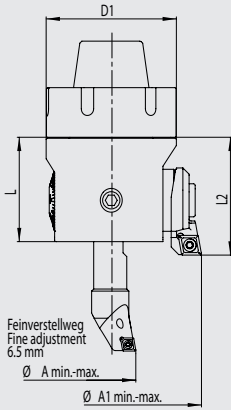

Bestell-Nr. / Order number	D1	L	L2	ø A min.	ø A max.	Ausdrehkopf / Fine boring head
783.001.010.101	63	50.5	57	9.75	101.1	205.040.003.152

Inhalt	Content	
1 Koffer / Case		
1 Ausdrehkopf / Fine boring head	ER40	205.040.003.152
1 Ausdrehstahl / Boring Bar	ø 9.75 - 20.1	254.010.006.075
1 Ausdrehstahl / Boring Bar	ø 19.75 - 30.1	254.020.006.105
1 Schaft / Shank	ø 29.75 - 48.1	256.030.048.115
1 Schaft / Shank	ø 47.75 - 88.1	256.048.088.115
1 Wendeplattenhalter / Insert holder	ø 29.75 - 48.1	256.030.006.012
1 Wendeplattenhalter / Insert holder	ø 47.75 - 88.1	256.048.006.014
1 Wendeplattenhalter / Insert holder CC . . 09 T3 . .	ø 87.75 - 101.1 (Ø114.1)	314.726.001.009
1 Kühlmittleinsatz / Coolant plug		900.805.000.032
2 Torx-Schlüssel / Torx driver	T7 / T15	900.254.007.000 900.254.009.000
1 Inbusschlüsselset / Allen wrench set	SW 1.5 - 8	900.892.015.080



Zubehör	Accessories	
Wendeplattenhalter / Insert holder CC . . 09 T3 . .	ø 105.75 - 119.0 (ø 132.0)	314.726.002.009
Wendeplattenhalter / Insert holder CC . . 09 T3 . .	ø 125.75 - 139.0 (ø 152.0)	314.726.003.009
Distanzstück / Adapter F = 6.5 mm	ø 114.0 / ø 132.0 / ø 152.0	900.803.001.006

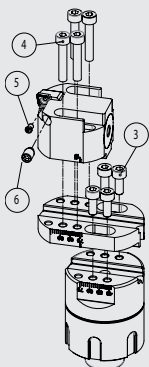

Ersatzteile / Zubehör

Spare parts / Accessories

Für Feinbohrkopf	Bestell-Nr. / Order number	Bestell-Nr. / Order number	Bestell-Nr. / Order number	Bestell-Nr. / Order number
For fine boring head	Schraube / Screw ③	Schraube / Screw ④	Torx-Schraube / Torx-Screw ⑤	Klemmschraube / Clamping screw ⑥
598.040.070.009	900.726.004.010	900.726.004.025	900.254.025.006	900.598.005.008

Spannsystem ST

Durch die seitliche Spannschraube (4) wird der Zapfen (2) in die Aufnahme (1) gezogen. Dank grosser Auflageflächen und hoher Vorspannung wird eine sehr grosse Steifigkeit erzielt. Zwei Nocken (3) sichern die genaue Schneidenorientierung und dienen zusätzlich als Mitnehmer. Am Grund der Aufnahmebohrung ist zusätzlich ein O-Ring (5) eingelegt.

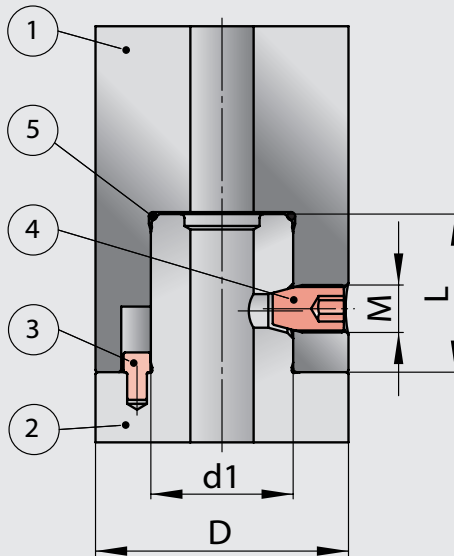

quick-change coupling system ST

The male pilot (2) will be clamped into the female receptacle (1) by using a radial clamping screw (4). A very high rigidity is achieved by a big contact surface and high prestress. Two drive lugs (3) ensure an accurate tip orientation and are used additionally for driving. On the female receptacle's base an O-ring (5) is fitted.

Spannsystem ST+

ST+ besitzt die gleichen Elemente wie ST, zusätzlich wird mittels einer Zugschraube (7) die Vorspannung massiv erhöht. Durch die extrem hohe Vorspannung wird die höchste Steifigkeit erreicht. Durch den Gewindering (6) wird die Zugschraube (7) in der Aufnahme befestigt.

Weil die Zugschraube (7) nur unter extremen Zerspannungsbedingungen benötigt werden alle ST+-Komponenten ohne Zugschraube (7) und Gewindering (6) ausgeliefert. Diese Bauteile müssen separat bestellt und durch den Kunden montiert werden.

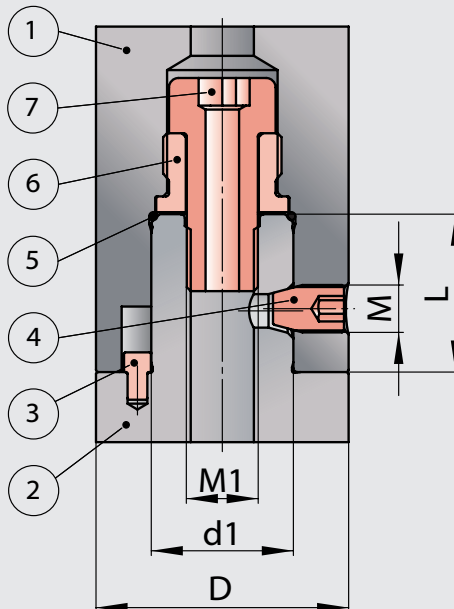

quick-change coupling system ST+

ST+ provides an additional feature for heavy machining applications. By using tension screw (7) a massive increase in prestress is achieved causing a maximum in rigidity. The tension screw (7) is fitted in female receptacle by a threaded ring (6).

Clamping of the system elements with the tension screw (7) is required only for extreme cutting conditions. Therefore the ST+-components are supplied without tension screw (7) and threaded ring (6). These parts must be ordered separately and assembled by the user.

höchste Steifigkeit

highest rigidity

Dimensionen		Dimensions			④	
ST	D	d1	L	M	Anzugsdrehmoment / Torque	M1
ST1	20	11	13	M4x0.5	2.5Nm	
ST2	25	14	16	M5x0.5	3Nm	
ST3	32	18	20	M6x0.75	5Nm	
ST4	39	22	24	M8x0.75	10Nm	
ST5	50	28	30	M10x1	20Nm	
ST6/ST6+	64	36	40	M12x1	40Nm	M18x2
ST7+	90	46	50	M20x1.5	60Nm	M24x2

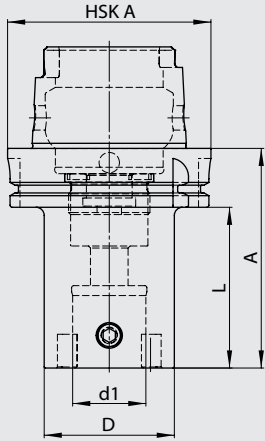

Bestell-Nr. / Order number	HSK A	ST	D	d1	A	L
144.806.020.042	63	ST1	20	11	42	16
144.806.025.042	63	ST2	25	14	42	16
144.806.032.044	63	ST3	32	18	44	18
144.806.039.048	63	ST4	39	22	48	22
144.806.050.059	63	ST5	50	28	59	33
144.806.064.070	63	ST6	64	36	70	44
144.806.064.100	63	ST6+	64	36	100	74
144.810.020.055	100	ST1	20	11	55	26
144.810.025.055	100	ST2	25	14	55	26
144.810.032.057	100	ST3	32	18	57	28
144.810.039.061	100	ST4	39	22	61	32
144.810.050.072	100	ST5	50	28	72	43
144.810.064.078	100	ST6	64	36	78	49
144.810.064.108	100	ST6+	64	36	108	79
144.810.090.127	100	ST7+	90	46	127	98



• ST+/HSK-Aufnahmen werden mit Gewinding ausgeliefert aber ohne Zugschraube

• ST+/HSK-shanks are supplied with threaded ring but without tension screw

Aufnahmen ISO 26623-1

Master shanks to ISO 26623-1

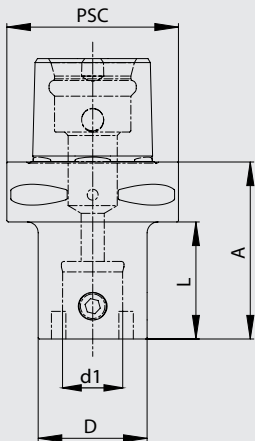

Bestell-Nr. / Order number	PSC	ST	D	d1	A	L
154.806.020.065	63	ST1	20	11	65	43
154.806.025.065	63	ST2	25	14	65	43
154.806.032.065	63	ST3	32	18	65	43
154.806.039.058	63	ST4	39	22	58	36
154.806.050.048	63	ST5	50	28	48	26
154.806.064.059	63	ST6	64	36	59	37
154.806.064.094	63	ST6+	64	36	94	72



• ST+-Aufnahmen werden ohne Zugschraube und Gewinding ausgeliefert

• ST+-shanks are supplied without tension screw and threaded ring

Ersatzteile / Zubehör

Spare parts / Accessories

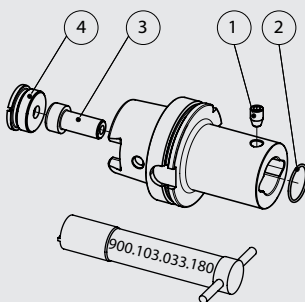

Für ST For ST	Bestell-Nr. / Order number	Bestell-Nr. / Order number	Bestell-Nr. / Order number	Bestell-Nr. / Order number
Für HSK A For HSK A	Klemmschraube / Clamping screw ①	O-Ring / O-ring ②	Zugschraube / Tension screw ③	Gewinding / Threaded ring ④
ST1	900.100.004.005	900.101.008.002		
ST2	900.100.005.006	900.101.011.002		
ST3	900.100.006.008	900.101.015.002		
ST4	900.100.008.011	900.101.019.002		
ST5	900.100.010.012	900.101.025.002		
ST6	900.100.012.018	900.101.032.002		
ST6+	900.100.012.018	900.101.032.002	900.102.018.040	
ST7+	900.100.020.029	900.101.043.002	900.102.024.045	
HSK A 63				900.104.030.014
HSK A 100				900.104.040.020



Bestell-Nr. / Order number	ISO	ST	D	d1	A	L	M
114.430.050.050	30	ST5	50	28	50	30.9	M12
114.440.020.035	40	ST1	20	11	35	15.9	M16
114.440.025.040	40	ST2	25	14	40	20.9	M16
114.440.032.040	40	ST3	32	18	40	20.9	M16
114.440.039.043	40	ST4	39	22	43	23.9	M16
114.440.050.043	40	ST5	50	28	43	23.9	M16
114.440.064.059	40	ST6+	64	36	59	39.9	M16
114.450.020.045	50	ST1	20	11	45	25.9	M24
114.450.025.050	50	ST2	25	14	50	30.9	M24
114.450.032.050	50	ST3	32	18	50	30.9	M24
114.450.039.053	50	ST4	39	22	53	33.9	M24
114.450.050.053	50	ST5	50	28	53	33.9	M24
114.450.064.069	50	ST6+	64	36	69	49.9	M24
114.450.090.085	50	ST7+	90	46	85	65.9	M24

• ST+-Aufnahmen werden ohne Zug-
schraube und Gewinding ausgeliefert

• ST+-shanks are supplied without ten-
sion screw and threaded ring

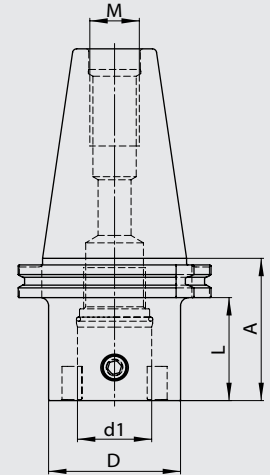

Bestell-Nr. / Order number	ISO	ST	D	d1	A	L	M
124.440.020.035	40	ST1	20	11	35	15.9	M16
124.440.025.040	40	ST2	25	14	40	20.9	M16
124.440.032.040	40	ST3	32	18	40	20.9	M16
124.440.039.043	40	ST4	39	22	43	23.9	M16
124.440.050.043	40	ST5	50	28	43	23.9	M16
124.440.064.059	40	ST6	64	36	59	39.9	M16
124.450.020.045	50	ST1	20	11	45	25.9	M24
124.450.025.050	50	ST2	25	14	50	30.9	M24
124.450.032.050	50	ST3	32	18	50	30.9	M24
124.450.039.053	50	ST4	39	22	53	33.9	M24
124.450.050.053	50	ST5	50	28	53	33.9	M24
124.450.064.069	50	ST6	64	36	69	49.9	M24

• Kühlmittelzufuhr über den Bund

• coolant supply through the tool
flange

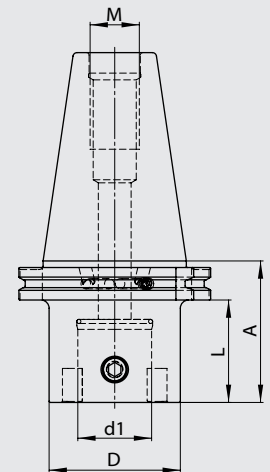

Bestell-Nr. / Order number	ISO	ST	D	d1	A	L	M
SP4.ST5.K01.043	40	ST5	50	28	41	25	M16
SP4.ST6.K01.059	40	ST6	64	36	59	43	M16
SP5.ST5.K01.053	50	ST5	50	28	51	35	M16
SP5.ST6.K01.069	50	ST6	64	36	69	53	M16
SP5.ST6.K01.100	50	ST6+	64	36	100	84	M24
SP5.ST7.K01.100	50	ST7+	90	46	100	84	M24

• Kühlmittelzufuhr über den Bund

• coolant supply through the tool
flange

• ST+-Aufnahmen werden ohne Zug-
schraube und Gewinding ausgeliefert

• ST+-shanks are supplied without ten-
sion screw and threaded ring

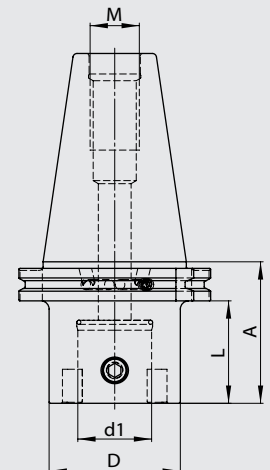

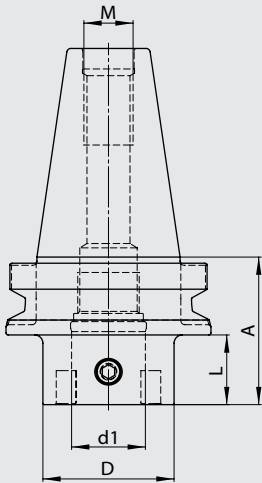

Bestell-Nr. / Order number	BT	ST	D	d1	A	L	M
134.530.050.038	30	ST5	50	28	38	16	M12
134.540.020.042	40	ST1	20	11	42	15	M16
134.540.025.042	40	ST2	25	14	42	15	M16
134.540.032.044	40	ST3	32	18	44	17	M16
134.540.039.048	40	ST4	39	22	48	21	M16
134.540.050.055	40	ST5	50	28	55	28	M16
134.540.064.046	40	ST6+	64	36	46	19	M16
134.550.020.063	50	ST1	20	11	63	25	M24
134.550.025.063	50	ST2	25	14	63	25	M24
134.550.032.065	50	ST3	32	18	65	27	M24
134.550.039.069	50	ST4	39	22	69	31	M24
134.550.050.072	50	ST5	50	28	72	34	M24
134.550.064.072	50	ST6+	64	36	72	34	M24
134.550.090.086	50	ST7+	90	46	86	48	M24



• ST+-Aufnahmen werden ohne Zug-
schraube und Gewinding ausgeliefert

• ST+-shanks are supplied without ten-
sion screw and threaded ring

Aufnahmen MAS-BT «B»

Master shanks to MAS-BT «B»

134.6xx

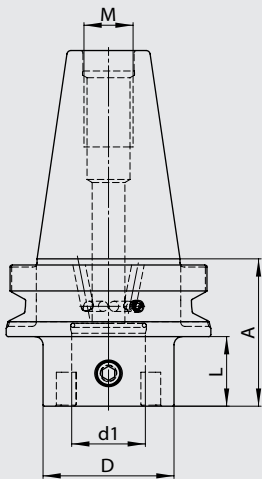

Bestell-Nr. / Order number	BT	ST	D	d1	A	L	M
134.640.020.042	40	ST1	20	11	42	15	M16
134.640.025.042	40	ST2	25	14	42	15	M16
134.640.032.044	40	ST3	32	18	44	17	M16
134.640.039.048	40	ST4	39	22	48	21	M16
134.640.050.055	40	ST5	50	28	55	28	M16
134.640.064.046	40	ST6	64	36	46	19	M16
134.650.020.063	50	ST1	20	11	63	25	M24
134.650.025.063	50	ST2	25	14	63	25	M24
134.650.032.065	50	ST3	32	18	65	27	M24
134.650.039.069	50	ST4	39	22	69	31	M24
134.650.050.072	50	ST5	50	28	72	34	M24
134.650.064.072	50	ST6	64	36	72	34	M24



• Kühlmittelzufuhr über den Bund

• coolant supply through the tool
flange

Aufnahmen MAS-BT «B»
mit Plananlage

Master shanks to MAS-BT «B»
with face contact

BP

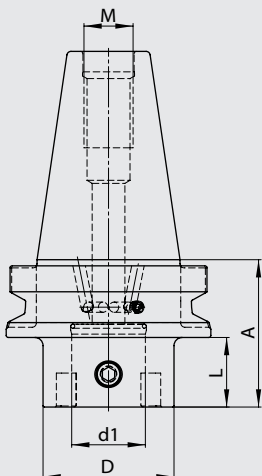

Bestell-Nr. / Order number	BT	ST	D	d1	A	L	M
BP4.ST5.K01.055	40	ST5	50	28	55	30	M16
BP4.ST6.K01.046	40	ST6	64	36	46	21	M16
BP5.ST5.K01.072	50	ST5	50	28	72	37	M24
BP5.ST6.K01.072	50	ST6	64	36	72	37	M24



• Kühlmittelzufuhr über den Bund

• coolant supply through the tool
flange

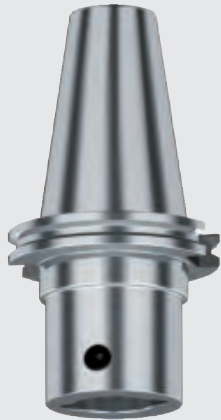

Bestell-Nr. / Order number	CAT	ST	D	d1	A	L	UNC
104.340.020.051	40	ST1	20	11	51	16	5/8"-11
104.340.025.056	40	ST2	25	14	56	21	5/8"-11
104.340.032.056	40	ST3	32	18	56	21	5/8"-11
104.340.039.059	40	ST4	39	22	59	24	5/8"-11
104.340.050.059	40	ST5	50	28	59	24	5/8"-11
104.340.064.075	40	ST6+	64	36	75	40	5/8"-11
104.350.020.061	50	ST1	20	11	61	26	1"-8
104.350.025.066	50	ST2	25	14	66	31	1"-8
104.350.032.066	50	ST3	32	18	66	31	1"-8
104.350.039.069	50	ST4	39	22	69	34	1"-8
104.350.050.069	50	ST5	50	28	69	34	1"-8
104.350.064.085	50	ST6+	64	36	85	50	1"-8
104.350.090.085	50	ST7+	90	46	85	50	1"-8

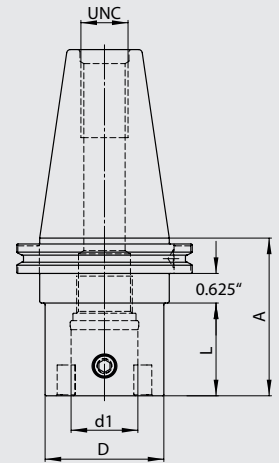

- ST+-Aufnahmen werden ohne Zugschraube und Gewinding ausgeliefert
- ST+-shanks are supplied without tension screw and threaded ring

PK

Adapter mit Gewinde

Thread adapter



Bestell-Nr. / Order number	ST	D	d1	M	A
PK4.ST1.K01.020	ST1	20	11	M10	20
PK5.ST2.K01.030	ST2	25	14	M12	30
PK6.ST3.K01.030	ST3	32	18	M16	30

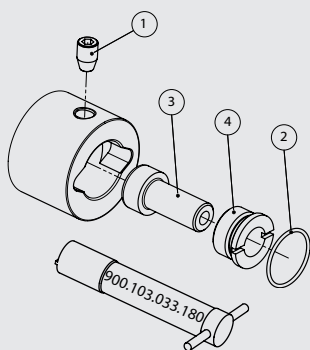
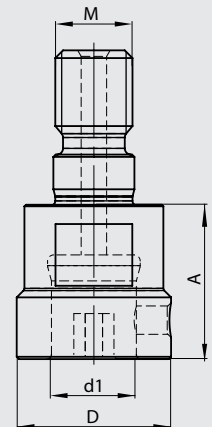

Ersatzteile / Zubehör

Spare parts / Accessories

114/124/134/154

Für ST For ST	Bestell-Nr. / Order number	Bestell-Nr. / Order number	Bestell-Nr. / Order number	Bestell-Nr. / Order number
	Klemmschraube / Clamping screw ①	O-Ring / O-ring ②	Zugschraube / Tension screw ③	Gewinding / Threaded ring ④
ST1	900.100.004.005	900.101.008.002		
ST2	900.100.005.006	900.101.011.002		
ST3	900.100.006.008	900.101.015.002		
ST4	900.100.008.011	900.101.019.002		
ST5	900.100.010.012	900.101.025.002		
ST6	900.100.012.018	900.101.032.002		
ST6+	900.100.012.018	900.101.032.002	900.102.018.040	900.103.030.020
ST7+	900.100.020.029	900.101.043.002	900.102.024.045	900.103.040.020

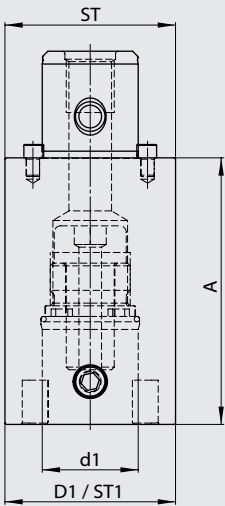

Bestell-Nr. / Order number	ST	ST1	D1	d1	A
164.020.020.020	ST1	ST1	20	11	20
164.020.020.030	ST1	ST1	20	11	30
164.025.025.030	ST2	ST2	25	14	30
164.025.025.045	ST2	ST2	25	14	45
164.032.032.030	ST3	ST3	32	18	30
164.032.032.045	ST3	ST3	32	18	45
164.039.039.040	ST4	ST4	39	22	40
164.039.039.060	ST4	ST4	39	22	60
164.050.050.060	ST5	ST5	50	28	60
164.050.050.090	ST5	ST5	50	28	90
164.064.064.060	ST6+	ST6	64	36	60
164.064.064.100	ST6+	ST6+	64	36	100
164.090.090.100	ST7+	ST7+	90	46	100
164.090.090.160	ST7+	ST7+	90	46	160



• ST+-Verlängerungen werden ohne Zug-
schraube und Gewindingerung ausgeliefert

• ST+-extensions are supplied without
tension screw and threaded ring

Ersatzteile / Zubehör

Spare parts / Accessories

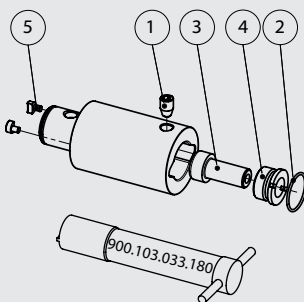

Für ST For ST	Bestell-Nr. / Order number	Bestell-Nr. / Order number	Bestell-Nr. / Order number	Bestell-Nr. / Order number	Bestell-Nr. / Order number
	Klemmschraube / Clamping screw ①	O-Ring / O-ring ②	Zugschraube / Tension screw ③	Gewindingerung / Threaded ring ④	Mitnehmer / Drive lug ⑤
ST1	900.100.004.005	900.101.008.002			900.102.020.000
ST2	900.100.005.006	900.101.011.002			900.102.025.000
ST3	900.100.006.008	900.101.015.002			900.102.032.000
ST4	900.100.008.011	900.101.019.002			900.102.039.000
ST5	900.100.010.012	900.101.025.002			900.102.050.000
ST6	900.100.012.018	900.101.032.002			900.102.064.000
ST6+	900.100.012.018	900.101.032.002	900.102.018.040	900.103.030.020	900.102.064.000
ST7+	900.100.020.029	900.101.043.002	900.102.024.045	900.103.040.020	900.102.090.000



Bestell-Nr. / Order number	ST	D	ST1	D1	D2	L	L1	L2
184.025.020.036	ST2	25	ST1	20	23	36	25	60.5
184.032.020.040	ST3	32	ST1	20	23	40.5	28	63.5
184.032.025.034	ST3	32	ST2	25	29	34.5	20	60
184.039.020.057	ST4	39	ST1	20	23	57.5	42	77.5
184.039.025.051	ST4	39	ST2	25	29	51.5	37	77
184.039.032.047	ST4	39	ST3	32	38	47	35	82
184.050.020.057	ST5	50	ST1	20	23	57.5	38.5	74
184.050.025.051	ST5	50	ST2	25	29	51.5	33.5	73.5
184.050.032.047	ST5	50	ST3	32	38	47.0	30.5	77.5
184.050.039.040	ST5	50	ST4	39	48	40.0	25.5	82.5
184.064.020.066	ST6+	64	ST1	20	23	66.5	45.5	81
184.064.020.101	ST6+	64	ST1	20	23	101.5	80.5	116
184.064.020.119	ST6+	64	ST1	20	23	119.5	100.5	136
184.064.020.139	ST6+	64	ST1	20	23	139.5	120.5	156
184.064.025.060	ST6+	64	ST2	25	29	60.5	40.5	80.5
184.064.025.095	ST6+	64	ST2	25	29	95.5	75.5	115.5
184.064.025.135	ST6+	64	ST2	25	29	135.0	115	155
184.064.025.175	ST6+	64	ST2	25	29	175.0	155	195
184.064.032.056	ST6+	64	ST3	32	38	56.0	37.5	84.5
184.064.032.091	ST6+	64	ST3	32	38	91.0	72	119
184.064.032.158	ST6+	64	ST3	32	38	158.0	139	186
184.064.032.198	ST6+	64	ST3	32	38	198.0	179	226
184.064.039.049	ST6+	64	ST4	39	48	49.0	32	89
184.064.039.084	ST6+	64	ST4	39	48	84.0	66.5	123.5
184.064.039.129	ST6+	64	ST4	39	48	129.0	111.5	168.5
184.064.039.218	ST6+	64	ST4	39	48	218.0	200.5	257.5
184.064.050.039	ST6+	64	ST5	50	60	39.0	24	104
184.064.050.074	ST6+	64	ST5	50	60	74.0	58.5	138.5
184.064.050.119	ST6+	64	ST5	50	60	119.0	103.5	183.5
184.064.050.234	ST6+	64	ST5	50	60	234.0	218	298
184.090.064.076	ST7+	90	ST6+	64	75	76	60	160

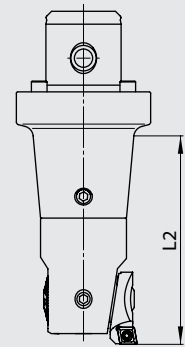
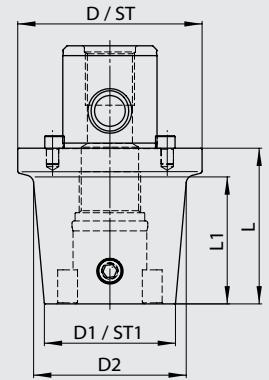

- Länge L2 bezeichnet die maximale Ausdrehtiefe mit Zweischneider- oder Feinbohrkopf
- length L2 stands for the maximal boring depth with twin cutter or fine boring head
- ST+-Reduktionen werden ohne Zugschraube und Gewinding ausgeliefert
- ST+-reductions are supplied without tension screw and threaded ring

Ersatzteile / Zubehör

Spare parts / Accessories

184

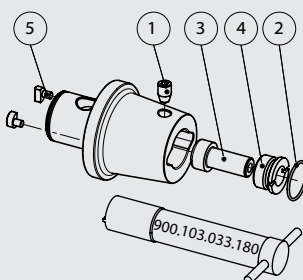

Für ST For ST	Bestell-Nr. / Order number	Bestell-Nr. / Order number	Bestell-Nr. / Order number	Bestell-Nr. / Order number	Bestell-Nr. / Order number
	Klemmschraube / Clamping screw ①	O-Ring / O-ring ②	Zugschraube / Tension screw ③	Gewinding / Threaded ring ④	Mitnehmer / Drive lug ⑤
ST1	900.100.004.005	900.101.008.002			900.102.020.000
ST2	900.100.005.006	900.101.011.002			900.102.025.000
ST3	900.100.006.008	900.101.015.002			900.102.032.000
ST4	900.100.008.011	900.101.019.002			900.102.039.000
ST5	900.100.010.012	900.101.025.002			900.102.050.000
ST6+	900.100.012.018	900.101.032.002	900.102.018.040	900.103.030.020	900.102.064.000
ST7+					900.102.090.000

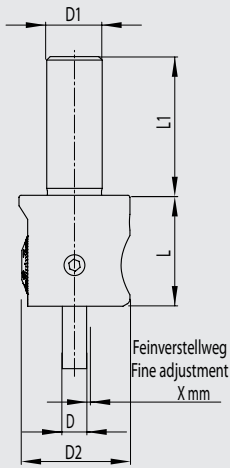

- Durchmessereinstellung mit geringstem Umkehrspiel
- Zustellgenauigkeit von 0.002mm über Nonius im Durchmesser
- mit Innenkühlung
- diametrical adjustment with maximal reduced reversal backlash
- 0.002mm diametrical adjustment by nonius
- with inner coolant supply

Bestell-Nr. / Order number	D	D1	D2	X	L	L1
<i>ANALOG</i>						
204.010.025.025	4	10	25	1.5	25	25
204.016.032.032	7	16	32	2.5	32	40

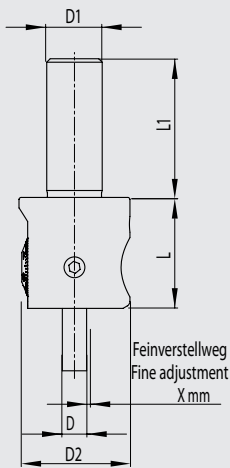

- Einstellgenauigkeit 0.001mm im Durchmesser
- direktes Wegmeßsystem (kein Umkehrspiel)
- keine Batterie und Auswerteelektronik im Werkzeug verbaut
- sehr einfache Bedienung
- digital und analog einsetzbar
- 0.001 accuracy in diameter
- direct measurement system (no backlash)
- no battery and electronic evaluation unit inside the tool
- very easy operation
- for digital and analog use

Bestell-Nr. / Order number	D	D1	D2	X	L	L1
<i>DIGITAL</i>						
206.010.025.025	4	10	25	1.5	25	25
206.016.032.032	7	16	32	2.5	32	40

- Anzeigeeinheit muss separat bestellt werden siehe Seite 6 (309.028.024.077).
- Display unit must be ordered separately see page 6 (309.028.024.077).

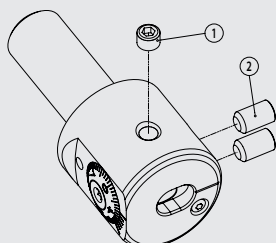

Für Ausdrehkopf For boring head	Bestell-Nr. / Order number	Bestell-Nr. / Order number
	Klemmschraube/ Clamping screw ①	Befestigungsschraube / Fastening screw ②
204/206.010.025.025	900.204.005.004	900.204.004.008
204/206.016.032.032	900.204.006.005	900.204.006.010

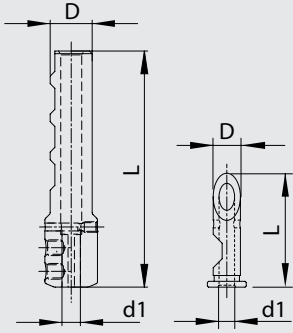

Bestell-Nr. / Order number	D	d1	L
224.007.004.030	7	4	(30)
224.016.004.090	16	4	90
224.016.007.090	16	7	90

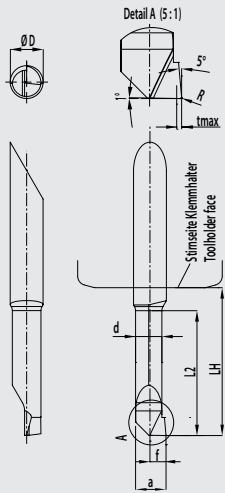

Bestell-Nr. / Order number	ØD	L2	Ød min	Ød max	R	a	d	f	LH	t max
255.004.003.013	4.0	1.2	0.3	0.7	-	0.25	0.15	0.15	11.0	0.03
255.004.006.013	4.0	2.5	0.6	1.1	-	0.55	0.46	0.30	11.0	0.05
255.004.010.013	4.0	4.0	1.0	2.3	0.05	0.95	0.65	0.50	11.0	0.1
255.004.022.013	4.0	6.0	2.2	3.3	0.05	2.00	1.55	1.10	11.0	0.2
255.004.032.013	4.0	10.2	3.2	4.3	0.05	3.00	2.55	1.60	11.0	0.2
255.004.039.018	4.0	15.2	3.9	(7.1)	0.05	3.70	3.45	1.95	16.0	0.3
255.007.052.023	7.0	20.3	5.2	6.3	0.05	5.00	4.25	2.60	21.0	0.5
255.007.062.023	7.0	20.3	6.2	7.3	0.05	6.00	5.25	3.10	21.0	0.5
255.007.069.028	7.0	25.4	6.9	(12.1)	0.20	6.70	6.25	3.45	26.0	0.5

• Schnittwerte (Start) f 0.02 mm/U

• Cutting parameters (Start) f 0.02 mm/rev

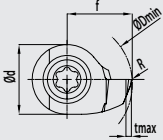

Bestell-Nr. / Order number	Ød min	Ød max	R	f	Ød	tmax	Code
283.007.069.004	6.9	8.1	0.2	3.45	4.8	1.0	D07
283.007.079.004	7.9	9.1	0.2	3.95	4.8	1.0	D07
283.007.089.004	8.9	10.1	0.2	4.45	4.8	1.0	D07
283.010.099.004	9.9	12.1	0.2	4.95	7	1.0	D10
283.010.119.004	11.9	14.1	0.2	5.95	7	1.0	D10
283.010.139.004	13.9	19.1	0.2	6.95	7	1.0	D10

• Schnittwerte (Start) f 0.02 mm/U

• Cutting parameters (Start) f 0.02 mm/rev

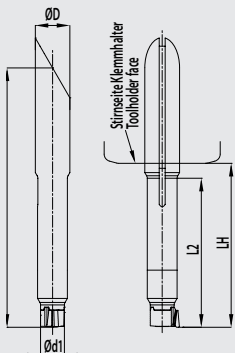

Bestell-Nr. / Order number	ØD h6	L2	Ø d1	L1	LH	Schraube / screw ^①	Torx	Code
282.007.007.033	7.0	30	4.8	56	31	M2x7.5 (900.254.020.007)	T7	D07
282.007.010.038	7.0	35	7.0	61	36	M3x9.0 (900.254.030.009)	T9	D10

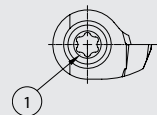

Ausdrehköpfe ø3-88.1

Fine boring heads ø3-88.1

204/208

- für Ausdrehstähle mit Schaftdurchmesser 16mm
- DurchmesserEinstellung mit geringstem Umkehrspiel
- Zustellgenauigkeit von 0.002mm über Nonius im Durchmesser
- mit Innenkühlung
- Ausdrehstähle durchschiebbar
- for boring bars with a shank diameter of 16mm
- diametrical adjustment with maximal reduced reversal backlash
- 0.002mm diametrical adjustment by nonius
- with inner coolant supply
- boring bars go through head

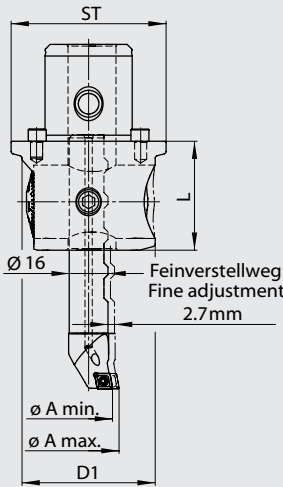

Bestell-Nr. / Order number	System	D1	ø A min.	ø A max.	L (A)	L1
ST modular ANALOG						
204.050.025.045	ST5	55	3	88.1	45	-
204.064.025.045	ST6	55	3	88.1	45	-
DIN 69893 HSK 63 A						
208.806.055.095	HSK 63 A	55	3	88.1	95	69
DIN 69871 AD 40						
208.440.055.090	ISO 40	55	3	88.1	90	70
MAS BT 40						
208.540.055.090	BT40	55	3	88.1	90	63

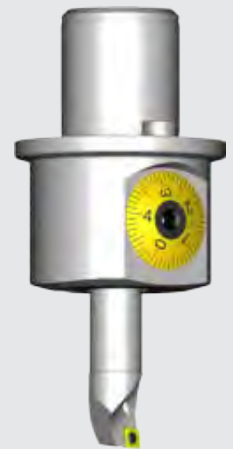

- die Ausdrehdurchmesser ø A min. - A max. werden mit Ausdrehstäben der Serien 254 bis 294 erreicht
- boring diameter ø A min. - A max. are only available with boring bars from series 254 to 294

Ausdrehköpfe ø3-88.1 DIGITAL

Fine boring heads ø3-88.1 DIGITAL

206

- für Ausdrehstähle mit Schaftdurchmesser 16mm
- Einstellgenauigkeit 0.001mm im Durchmesser
- direktes Wegmeßsystem (kein Umkehrspiel)
- keine Batterie und Auswerteelektronik im Werkzeug verbaut
- sehr einfache Bedienung
- digital und analog einsetzbar
- mit Innenkühlung
- Ausdrehstähle durchschiebbar
- for boring bars with a shank diameter of 16mm
- 0.001 accuracy in diameter
- direct measurement system (no backlash)
- no battery and electronic evaluation unit inside the tool
- very easy operation
- for digital and analog use
- with inner coolant supply
- boring bars go through head

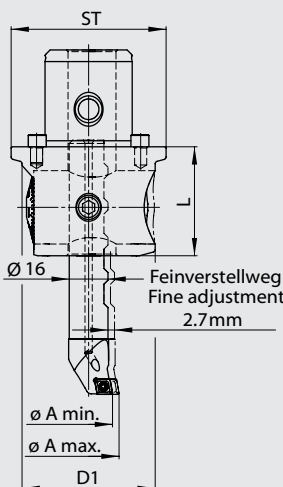

Bestell-Nr. / Order number	System	D1	ø A min.	ø A max.	L (A)	L1
ST modular DIGITAL						
206.050.025.045	ST5	55	3	88.1	45	-
206.064.025.045	ST6	55	3	88.1	45	-

- die Ausdrehdurchmesser ø A min. - A max. werden mit Ausdrehstäben der Serien 254 bis 294 erreicht
- Anzeigeeinheit muss separat bestellt werden siehe Seite 6 (309.028.024.077).
- boring diameter ø A min. - A max. are only available with boring bars from series 254 to 294
- Display unit must be ordered separately see page 6 (309.028.024.077).



ECO LINE



- erweiterbar von $\varnothing 3$ bis $\varnothing 88.1$
- Schnittstelle ER32 DIN6499
- can be upgraded from $\varnothing 3$ up to $\varnothing 88.1$
- connection ER32 DIN 6499

Bestell-Nr. / Order number	$\varnothing D$ / System	$\varnothing A$ min.	$\varnothing A$ max.	L (A)	L1
SMART ER32					
211.032.055.060	55 / ER32	9.75	30.1	60	-

- Werkzeug in einem Spannzangenfutter spannen.
- Clamp tool in a collet chuck.

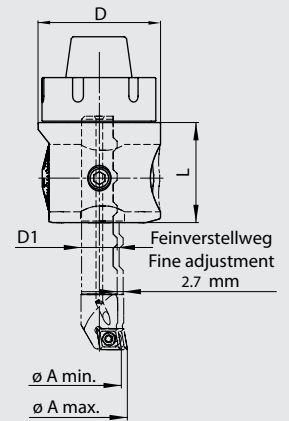

Ausdrehköpfe $\varnothing 3-88.1$
DIGITAL

Fine boring heads $\varnothing 3-88.1$
DIGITAL

PSC FBHO



- für Ausdrehstähle mit Schaftdurchmesser 16mm
- Einstellgenauigkeit 0.001mm im Durchmesser
- direktes Wegmeßsystem (kein Umkehrspiel)
- keine Batterie und Auswerteelektronik im Werkzeug verbaut
- sehr einfache Bedienung
- digital und analog einsetzbar
- mit Innenkühlung
- for boring bars with a shank diameter of 16mm
- 0.001 accuracy in diameter
- direct measurement system (no backlash)
- no battery and electronic evaluation unit inside the tool
- very easy operation
- for digital and analog use
- with inner coolant supply

Bestell-Nr. / Order number	System	D1	$\varnothing A$ min.	$\varnothing A$ max.	L (A)	L1
PSC DIGITAL						
PSC40-FBHO-DE-1665	PSC40	55	3	88.1	65	-
PSC50-FBHO-DE-1670	PSC50	55	3	88.1	70	-
PSC63-FBHO-DE-1690	PSC63	55	3	88.1	90	-

- die Ausdrehdurchmesser $\varnothing A$ min. - A max. werden mit Ausdrehstählen der Serien 254 bis 294 erreicht
- boring diameter $\varnothing A$ min. - A max. are only available with boring bars from series 254 to 294



- Anzeigeeinheit muss separat bestellt werden siehe Seite 6 (C09.028.024.077).
- Display unit must be ordered separately see page 6 (C09.028.024.077).

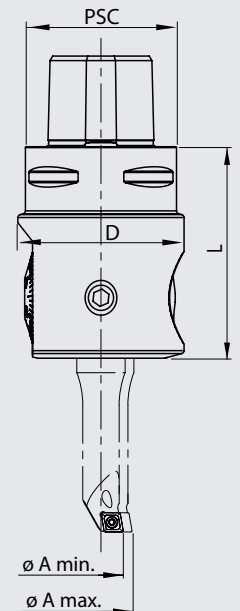

Ausdrehkopf ø3-152.1

Fine boring head ø3-152.1

ECO LINE 205

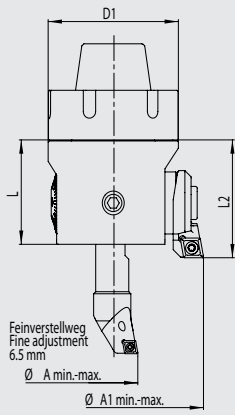

- Schnittstelle ER40 DIN6499
- Zustellgenauigkeit 0.01mm resp. über Nonius 0.002mm im Durchmesser
- erweiterbar von ø3 bis ø152.1

- connection ER40 DIN 6499
- 0.01mm diametrical adjustment resp. 0.002mm by nonius
- can be upgraded from ø3 up to ø152.1

Bestell-Nr. / Order number	Ø D/ System	Ø A min.	Ø A max.	L (A)	L2
VARIO ER40					
205.040.003.152	63 / ER40	9.75	152.1	50.5	57

- die Ausdrehdurchmesser ø A min. - A max. werden mit Ausdrehstäben der Serien 254 bis 294 erreicht

- boring diameter ø A min. - A max. are only available with boring bars from series 254 to 294



Zubehör

Accessories

Wendeplattenhalter / Insert holder CC . . 09 T3 . .	ø 105.75 - 119.0 (ø 132.0)	314.726.002.009
Wendeplattenhalter / Insert holder CC . . 09 T3 . .	ø 125.75 - 139.0 (ø 152.0)	314.726.003.009
Distanzstück / Adapter F = 6.5 mm	ø 114.0 / ø 132.0 / ø 152.0	900.803.001.006



Ausdrehkopf ø3-152.1

Fine boring head ø3-152.1

205

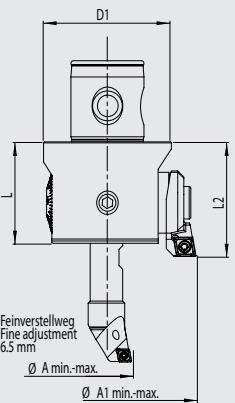

- für Ausdrehstäbe mit Schaftdurchmesser 16mm
- DurchmesserEinstellung mit geringstem Umkehrspiel
- Zustellgenauigkeit von 0.01mm resp. über Nonius 0.002mm im Durchmesser
- mit Innenkühlung
- Ausdrehstäbe durchschiebbar

- for boring bars with a shank diameter of 16mm
- diametrical adjustment with maximal reduced reversal backlash
- 0.01mm diametrical adjustment resp. 0.002mm by nonius
- with inner coolant supply
- boring bars go through head

Bestell-Nr. / Order number	Ø D/ System	Ø A min.	Ø A max.	L (A)	L2
VARIO ST6					
205.064.025.050	ST6	9.75	152.1	50.5	57

- die Ausdrehdurchmesser ø A min. - A max. werden mit Ausdrehstäben der Serien 254 bis 294 erreicht

- boring diameter ø A min. - A max. are only available with boring bars from series 254 to 294



Zubehör

Accessories

Wendeplattenhalter / Insert holder CC . . 09 T3 . .	ø 105.75 - 119.0 (ø 132.0)	314.726.002.009
Wendeplattenhalter / Insert holder CC . . 09 T3 . .	ø 125.75 - 139.0 (ø 152.0)	314.726.003.009
Distanzstück / Adapter F = 6.5 mm	ø 114.0 / ø 132.0 / ø 152.0	900.803.001.006

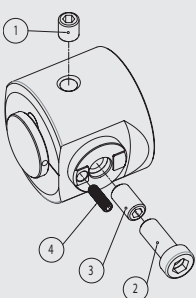
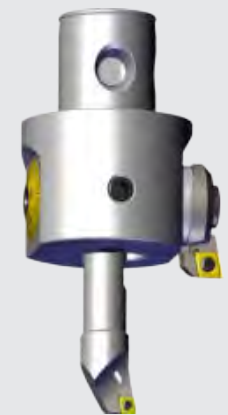

Ersatzteile / Zubehör

Spare parts / Accessories

205

Für Feinbohrkopf For fine boring head	Bestell-Nr. / Order number	Bestell-Nr. / Order number	Bestell-Nr. / Order number	Bestell-Nr. / Order number
	Klemmschraube / Clamping screw ①	Schraube / Screw ②	Schraube / Screw ③	Schraube / Screw ④
205.040.003.152	900.205.010.012	900.205.010.025	900.205.010.018	900.205.003.014
205.064.025.050	900.205.010.012	900.205.010.025	900.205.010.018	900.205.003.014

Ausdrehkopf ø3-320

Fine boring head ø3-320

- für Ausdrehstähle mit Schaftdurchmesser 16mm und Feinbohrbrücken
 - DurchmesserEinstellung mit geringstem Umkehrspiel
 - Zustellgenauigkeit von 0.002mm über Nonius im Durchmesser
 - mit Innenkühlung
 - Ausdrehstähle durchschiebbar
- for boring bars with a shank diameter of 16mm and fine boring bridges
 - diametrical adjustment with maximal reduced reversal backlash
 - 0.002mm diametrical adjustment by nonius
 - with inner coolant supply
 - boring bars go through head



Bestell-Nr. / Order number	System	D1	ø A min.-max.	ø A1 min.-max.	L (A)	L1	L2
ST6 modular							
210.064.025.065	ST6	63	3 - 88.1	86 - 320	67	-	95
DIN 69893 HSK 63 A							
210.806.063.095	HSK 63 A	63	3 - 88.1	86 - 320	96	72	125
DIN 69871 AD 40							
210.440.063.090	ISO 40	63	3 - 88.1	86 - 320	91	81	120
MAS BT 40							
210.540.063.090	BT40	63	3 - 88.1	86 - 320	91	81	120

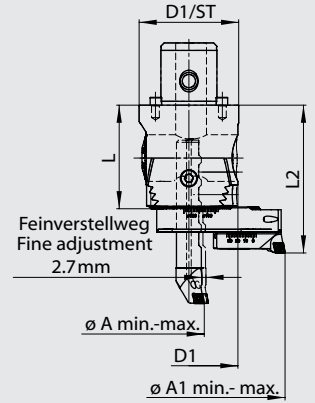

- die Ausdrehdurchmesser ø A min.-max. werden mit Ausdrehstählen der Serien 254 bis 294 erreicht
 - die Ausdrehdurchmesser ø A1 min.-max. werden mit Feinbohrbrücken der Serie 212 erreicht
- boring diameters ø A min.-max. are only available with boring bars from series 254 to 294
 - boring diameters ø A min.-max. are only available with fine boring bridges from serie 212

Feinbohrbrücken ø86-320

Fine boring bridges ø86-320

Aluminium-Brücken

Aluminium bridges

- mit Innenkühlung

- with inner coolant supply



Bestell-Nr. / Order number	D	ø A min.	ø A max.
212.086.164.080	80	86	164
212.162.320.158	158	162	320

Wendepplattenhalter

Insert holders

- mit Innenkühlung

- with inner coolant supply



Bestell-Nr. / Order number	Wendepplatte / Insert	ø A min.	ø A max.
256.048.006.014	CC .. 06 02 ..	86	320
256.048.009.014	CC .. 09 T3 ..	86	320

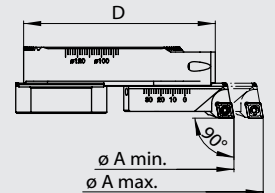

Gegengewicht

Counter weight

- für hohe Drehzahlen

- for high revolution speed



Bestell-Nr. / Order number
212.038.045.012

Ersatzteile / Zubehör

Spare parts / Accessories

204/206/208/210

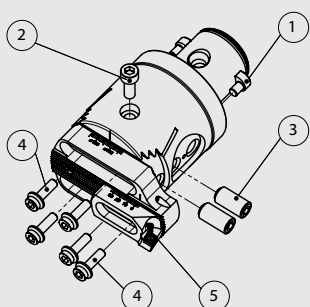

Für Ausdrehkopf / For boring head	Bestell-Nr. / Order number ①	Bestell-Nr. / Order number ②	Bestell-Nr. / Order number ③	Bestell-Nr. / Order number ④
	Mitnehmer / Drive lug	Klemmschraube / Clamping screw	Befestigungsschraube / Fastening screw	Befestigungsschraube / Fastening screw
	210.064.025.065	900.102.064.000	900.210.006.016	900.210.010.020
	204.050.025.045	900.102.050.000	900.204.010.008	900.204.010.016
	204/206.064.025.045	900.102.064.000	900.204.010.008	900.204.010.016
Für Wp-Halter / For insert holder	Bestell-Nr. / Order number ⑤	Bestell-Nr. / Order number		
	Torx-Schraube / Torx screw	Torx-Schlüssel / Torx driver		
	256.xxx.006.xxx	900.254.025.006	900.254.007.000	
	256.xxx.009.xxx	900.254.040.009	900.254.009.000	

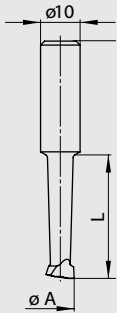

Bestell-Nr. / Order number	$\varnothing A$ min.	$\varnothing A$ max.	L	HM Sorte / Carbide quality
264.003.010.020	3.0	8.0	20	K10
264.003.020.020	3.0	8.0	20	P20
264.004.010.023	4.0	9.0	23	K10
264.004.020.023	4.0	9.0	23	P20
264.005.010.025	5.0	10.0	25	K10
264.005.020.025	5.0	10.0	25	P20
264.006.010.028	6.0	11.0	28	K10
264.006.020.028	6.0	11.0	28	P20
264.007.010.031	7.0	12.0	31	K10
264.007.020.031	7.0	12.0	31	P20
264.009.010.034	9.0	14.0	34	K10
264.009.020.034	9.0	14.0	34	P20
264.010.010.037	10.0	15.0	37	K10
264.010.020.037	10.0	15.0	37	P20
264.012.010.040	12.0	17.0	40	K10
264.012.020.040	12.0	17.0	40	P20
264.014.010.043	14.0	19.0	43	K10
264.014.020.043	14.0	19.0	43	P20



- die Ausdrehdurchmesser $\varnothing A$ min. - A max. werden mit Ausdrehköpfen der Serien 204 bis 210 erreicht
- Hartmetall Sorte K10 für Guss, Aluminium usw.
- Hartmetall Sorte P20 für Stahl, Chromnickelstahl usw.
- boring diameters $\varnothing A$ min. - A max. are only available with fine boring heads from series 204 to 210
- carbide quality K10 for cast iron, aluminium etc.
- carbide quality P20 for steel, chrome nickel steel etc.

**Ausdrehstähle
mit Hartmetallschaft**

**Boring bars
with solid carbide shank**

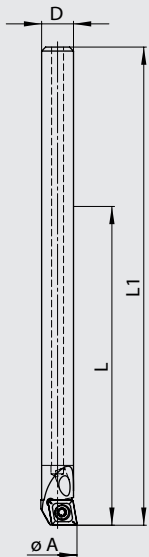

Bestell-Nr. / Order number	$\varnothing A$ min.	$\varnothing A$ max.	D	L	L1	Wendeplatte / Insert
274.006.002.080	5.8	11.2	5	50	85	WC .. 02 01 ..
274.008.002.100	7.8	13.2	6	60	95	WC .. 02 01 ..
274.010.006.120	9.8	15.0	8	80	120	CC .. 06 02 ..
274.014.006.140	13.8	19.0	10	100	140	CC .. 06 02 ..
274.018.009.170	17.8	23.0	12	120	170	CC .. 09 T3 ..
274.022.009.210	21.8	27.0	16	160	210	CC .. 09 T3 ..



- Länge L bezeichnet die maximale Ausdrehlänge
- die Ausdrehdurchmesser $\varnothing A$ min. - A max. werden mit Ausdrehköpfen der Serien 204 bis 210 erreicht
- length L stands for the maximal boring depth
- boring diameters $\varnothing A$ min. - A max. are only available with fine boring heads from series 204 to 210

Ersatzteile / Zubehör

Spare parts / Accessories

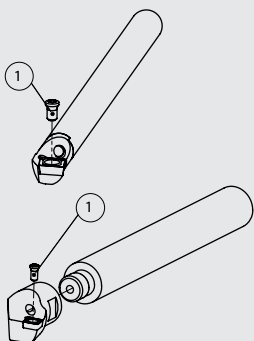

Für Ausdrehstahl For boring bar	Bestell-Nr. / Order number	Bestell-Nr. / Order number
	Torx-Schraube / Torx screw	Torx-Schlüssel / Torx driver
274.xxx.002.xxx	900.254.020.004	900.254.006.000
274.010.006.120	900.254.025.005	900.254.007.000
274.xxx.006.xxx	900.254.025.006	900.254.007.000
274.xxx.009.xxx	900.254.040.009	900.254.009.000
Für Kopf For head		
294.009-012.006.xxx	900.254.025.005	900.254.007.000
294.013-035.006.xxx	900.254.025.006	900.254.007.000

**Hartmetall Ausdrehstähle
mit Schraubverbindung**
**Solid carbide boring bars
with thread connection**

- zum Ausdrehen von langen Bohrungen
- sehr gute Dämpfungseigenschaften durch Hartmetallschaft
- mit Innenkühlung
- to machine deep holes
- high end absorbability by solid carbide shank
- with inner coolant supply

Kopf / head Bestell-Nr. / Order number	ø A min.	ø A max.	D	L max.	L2	Wende- platte / Insert	für Schaft / for shank Bestell-Nr. / Order number
294.009.006.018	8.75	14.1	8	56	18	CC..06 02..	284.008.005.073
294.010.006.018	9.75	15.1	9	63	18	CC..06 02..	284.009.005.080
294.011.006.023	10.75	16.1	10	70	23	CC..06 02..	284.010.006.082
294.012.006.023	11.75	17.1	11	77	23	CC..06 02..	284.011.006.089
294.013.006.023	12.75	18.1	12	84	23	CC..06 02..	284.012.006.096
294.014.006.023	13.75	19.1	13	91	23	CC..06 02..	284.013.006.103
294.015.006.023	14.75	20.1	14	98	23	CC..06 02..	284.014.006.110
294.016.006.023	15.75	21.1	14	98	23	CC..06 02..	284.014.006.110
294.017.006.027	16.75	22.1	16	112	27	CC..06 02..	284.016.010.120
294.018.006.027	17.75	23.1	16	112	27	CC..06 02..	284.016.010.120
294.020.006.027	19.75	25.1	16	112	27	CC..06 02..	284.016.010.120
294.022.006.027	21.75	27.1	16	112	27	CC..06 02..	284.016.010.120
294.025.006.027	24.75	30.1	16	112	27	CC..06 02..	284.016.010.120
294.028.006.027	27.75	33.1	16	112	27	CC..06 02..	284.016.010.120
294.032.006.027	31.75	37.1	16	112	27	CC..06 02..	284.016.010.120
294.035.006.027	34.75	40.1	16	112	27	CC..06 02..	284.016.010.120

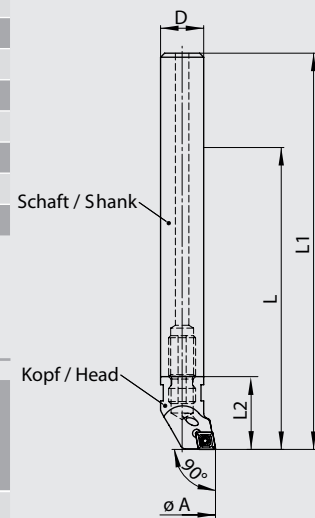
Hartmetallschaft
Solid carbide shank

Schaft / shank Bestell-Nr. / Order number	D	L1	für Kopf / for head Bestell-Nr. / Order number
284.008.005.073	8	91	294.009.006.018
284.009.005.080	9	98	294.010.006.018
284.010.006.082	10	105	294.011.006.023
284.011.006.089	11	112	294.012.006.023
284.012.006.096	12	119	294.013.006.023
284.013.006.103	13	126	294.014.006.023
284.014.006.110	14	133	294.015/016.006.023
284.016.010.120	16	147	294.017/018/020/022/025//028/032/035.006.027

Reduktionshülsen
Reduction sleeves

Bestell-Nr. / Order number	D	d1	L
224.016.004.037	16	4	37
224.016.005.037	16	5	37
224.016.006.037	16	6	37
224.016.008.037	16	8	37
224.016.009.037	16	9	37
224.016.010.037	16	10	37
224.016.011.037	16	11	37
224.016.012.037	16	12	37
224.016.013.037	16	13	37
224.016.014.037	16	14	37

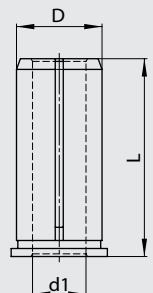

Ausdrehstähle ø9.75-30.1

Boring bars ø9.75-30.1

254

- mit Innenkühlung
- werden die Ausdrehstähle zentrisch gespannt (Weldonfutter), kann mit ø A min. ausgedreht werden

- with inner coolant supply
- if the boring bars are clamped centrally (weldon adapter), the minimum diameter (ø A min.) is provided

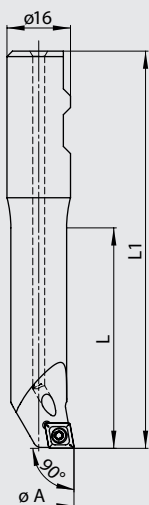

Bestell-Nr. / Order number	ø A min.	ø A max.	L	L1	Wendeplatte / Insert
254.010.006.075	9.75	15.1	30	75	CC .. 06 02 ..
254.012.006.080	11.75	17.1	37	80	CC .. 06 02 ..
254.014.006.085	13.75	19.1	43	85	CC .. 06 02 ..
254.015.006.090	14.75	20.1	51	90	CC .. 06 02 ..
254.016.006.095	15.75	21.1	57	95	CC .. 06 02 ..
254.018.006.100	17.75	23.1	67	100	CC .. 06 02 ..
254.020.006.105	19.75	25.1	72	105	CC .. 06 02 ..
254.020.009.105	19.75	25.1	72	105	CC .. 09 T3 ..
254.022.009.110	21.75	27.1	77	110	CC .. 09 T3 ..
254.025.006.115	24.75	30.1	82	115	CC .. 06 02 ..
254.025.009.115	24.75	30.1	82	115	CC .. 09 T3 ..
254.028.009.115	27.75	33.1	82	115	CC .. 09 T3 ..
254.030.006.115	29.75	35.1	82	115	CC .. 06 02 ..
254.032.009.115	31.75	37.1	82	115	CC .. 09 T3 ..
254.035.006.115	34.75	40.1	82	115	CC .. 06 02 ..
254.035.009.115	34.75	40.1	82	115	CC .. 09 T3 ..
254.039.009.115	38.75	44.1	82	115	CC .. 09 T3 ..
254.043.009.115	42.75	48.1	82	115	CC .. 09 T3 ..

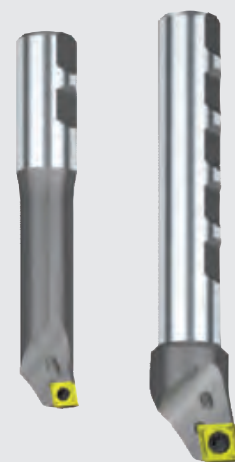

Ausdrehstähle ø9.75-30.1

Boring bars ø9.75-30.1

253

- mit Innenkühlung
- werden die Ausdrehstähle zentrisch gespannt (Weldonfutter), kann mit ø A min. ausgedreht werden

- with inner coolant supply
- if the boring bars are clamped centrally (weldon adapter), the minimum diameter (ø A min.) is provided

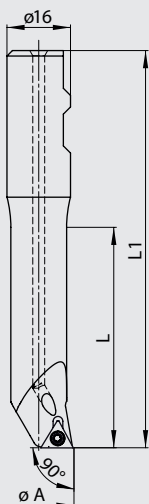

Bestell-Nr. / Order number	ø A min.	ø A max.	L	L1	Wendeplatte / Insert
253.010.T06.075	9.75	15.1	30	75	TB .. 06 01 ..
253.012.T06.080	11.75	17.1	37	80	TB .. 06 01 ..
253.014.T09.085	13.75	19.1	43	85	TP .. 09 02 ..
253.015.T09.090	14.75	20.1	51	90	TP .. 09 02 ..
253.016.T09.095	15.75	21.1	57	95	TP .. 09 02 ..
253.018.T09.100	17.75	23.1	67	100	TP .. 09 02 ..
253.020.T11.105	19.75	25.1	72	105	TP .. 11 03 ..
253.025.T11.115	24.75	30.1	82	115	TP .. 11 03 ..

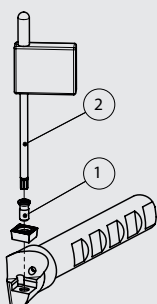

Ersatzteile / Zubehör

Spare parts / Accessories

254

Für Ausdrehstahl For boring bar	Bestell-Nr. / Order number	Bestell-Nr. / Order number
	Torx-Schraube / Torx screw (1)	Torx-Schlüssel / Torx driver (2)
254.010.006.075	900.254.025.005	900.254.007.000
254.xxx.006.xxx	900.254.025.006	900.254.007.000
254.xxx.009.xxx	900.254.040.009	900.254.009.000



Hartmetallschaft

- sehr gute Dämpfungseigenschaften
- mit Innenkühlung

Carbide shank

- high end absorbability
- with inner coolant supply

Bestell-Nr. / Order number	D	L2	für Kopf / for head
284.016.010.120	16	120	256.130.048.033 256.148.088.031

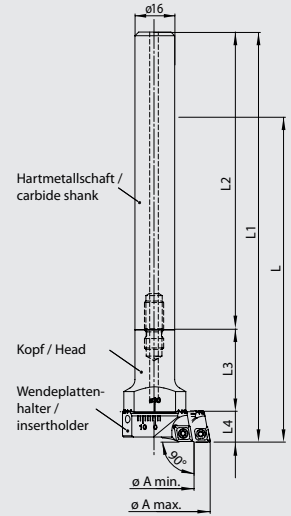

Kopf

- mit Innenkühlung

Head

- with inner coolant supply

Bestell-Nr. / Order number	ø A min.	ø A max.	L	L1	L3	für Wendeplattenhalter / for insert holder
256.030.048.033	29.75	48.1	135	165	33	256.030.006.012
256.048.088.031	47.75	88.1	135	165	31	256.048.xxx.014



Stahlschäfte

- mit Innenkühlung

Steel shanks

- with inner coolant supply

Bestell-Nr. / Order number	ø A min.	ø A max.	L	L1	für Wendeplattenhalter / for insert holder
256.030.048.115	29.75	48.1	85	115	256.030.006.012
256.048.088.115	47.75	88.1	85	115	256.048.xxx.014

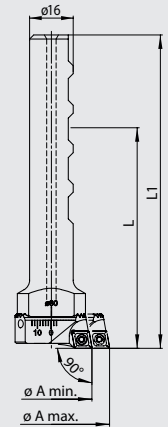

Wendeplattenhalter

- mit Innenkühlung

Insert holders

- with inner coolant supply

Bestell-Nr. / Order number	ø A min.	ø A max.	L4	Wendeplatte / Insert
256.030.006.012	29.75	48.1	12	CC .. 06 02 ..
256.048.006.014	47.75	88.1	14	CC .. 06 02 ..
256.048.009.014	47.75	88.1	14	CC .. 09 T3 ..



- Schäfte und Wendeplattenhalter müssen separat bestellt werden

- shanks and insert holder must be ordered separately

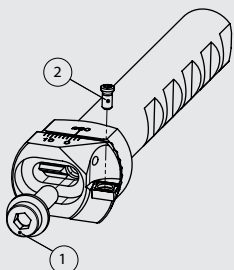

Ersatzteile / Zubehör

Spare parts / Accessories

Für Schaft For shank	Bestell-Nr. / Order number	Für Wp-Halter For insert holder	Bestell-Nr. / Order number	Bestell-Nr. / Order number
	Befestigungsschraube / Fastening screw (1)		Torx-Schraube / Torx screw (2)	Torx-Schlüssel / Torx driver
256.030.048.115	900.256.005.016	256.xxx.006.xxx	900.254.025.006	900.254.007.000
256.048.088.115	900.256.005.016	256.xxx.009.xxx	900.254.040.009	900.254.009.000

- für die Verwendung in Ausdrehköpfen der Serien 204 bis 210
- mit Innenkühlung

- for use in fine boring heads from series 204 to 210
- with inner coolant supply

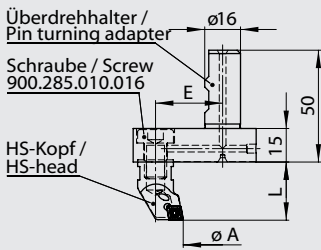

Überdrehhalter / Pin turning adapter Bestell-Nr. / Order number	HS-Kopf / HS-head Bestell-Nr. / Order number	ø A min.	ø A max.	E	L	Wende- platte / Insert
285.020.010.050	294.035.006.027	5.3	10.6	20	27	CC..06 02..
285.020.010.050	294.032.006.027	8.3	13.6	20	27	CC..06 02..
285.020.010.050	294.028.006.027	12.3	17.6	20	27	CC..06 02..
285.020.010.050	294.025.006.027	15.3	20.6	20	27	CC..06 02..
285.020.010.050	294.022.006.027	18.3	23.6	20	27	CC..06 02..
285.020.010.050	294.020.006.027	20.3	25.6	20	27	CC..06 02..
285.020.010.050	294.018.006.027	22.3	27.6	20	27	CC..06 02..
285.020.010.050	294.017.006.027	23.3	28.6	20	27	CC..06 02..
285.030.010.050	294.035.006.027	25.3	30.6	30	27	CC..06 02..
285.030.010.050	294.032.006.027	28.3	33.6	30	27	CC..06 02..
285.030.010.050	294.028.006.027	32.3	37.6	30	27	CC..06 02..
285.030.010.050	294.025.006.027	35.3	40.6	30	27	CC..06 02..
285.030.010.050	294.022.006.027	38.3	43.6	30	27	CC..06 02..
285.030.010.050	294.020.006.027	40.3	45.6	30	27	CC..06 02..
285.030.010.050	294.018.006.027	42.3	47.6	30	27	CC..06 02..
285.030.010.050	294.017.006.027	43.3	48.6	30	27	CC..06 02..

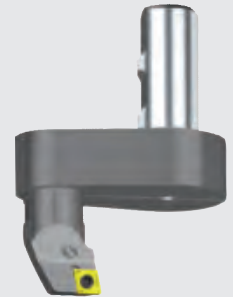

- die maximale Überdrehlänge L kann mit der Verlängerung 286.016.016.032 oder 286.016.016.064 verlängert werden
- Überdrehhalter und Kopf müssen separat bestellt werden
- **Achtung: Linkslauf**

- the maximal turning length L can be increased by extension 286.016.016.032 or 286.016.016.064
- pin turning adapter and head must be ordered separately
- **Caution: anticlockwise rotation**

HS-Schaftverlängerungen

HS-shank extensions

- zur Verlängerung von HS-Schäften und Überdrehhalter
- mit Innenkühlung
- aus gehärtetem Stahl

- to extend HS-shanks and pin turning adapter
- with inner coolant supply
- made of hardened steel

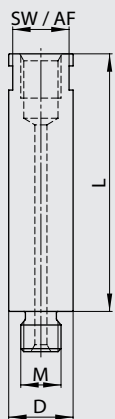

Bestell-Nr. / Order number	D	L	M	SW / AF
286.016.016.032	16	32	M10	14
286.016.016.064	16	64	M10	14

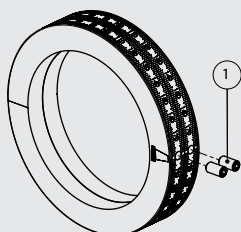
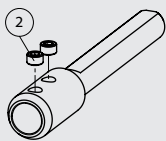

Ersatzteile / Zubehör

Spare parts / Accessories

Für Auswuchtring For balancing ring	Bestell-Nr. / Order number	Für Ausdrehstahl-Verlängerung For boring bar extension	Bestell-Nr. / Order number
	Klemmschraube / Clamp screw (1)		Spannschraube / Clamp screw (2)
216.xxx.xxx.016	900.216.004.008	234.016.010.128	900.234.006.003
			900.234.008.005

Einstellvorrichtung

Setting Jig



- Orientierung der Werkzeugschneide
- Einstellung der Auskräglänge der Bohrstange
- Grobeinstellung des Ausdrehdurchmessers

- alignment of the cutting edge
- adjustment of the boring bar projection length
- coarse diameter adjustment

Bestell-Nr. / Order number	D	L	für Ausdrehkopf/ for fine boring head
200.055.055.197	55	197	204 /208
200.063.063.197	63	197	206
200.163.063.207	63	207	210

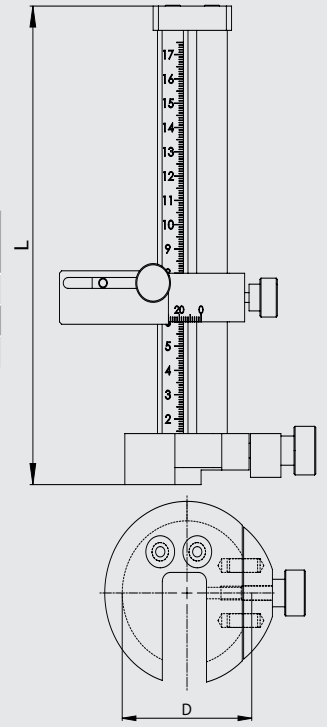
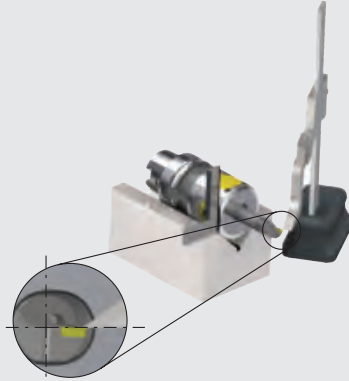

Universal-Auswuchtringe

Universal balancing rings

- zum Auswuchten verstellbarer Werkzeuge, z.B. Ausdrehköpfe der Serien 204 - 206
- für die Ausdrehköpfe der Serie 204 und 206 (mit den Ausdrehstäben der Serie 254,274,284,294) sind Einstelltabelle verfügbar, womit die Unwucht über 90% reduziert wird

- to balance adjustable tools, e.g. fine boring heads from series 204-206
- balancing charts for fine boring heads from serie 204 and 206 (with boring bars from serie 254,274,284,294) are available in order to reduce unbalance by 90%



Bestell-Nr. / Order number	D	d1	L
216.050.070.016	70	50	16
216.055.075.016	75	55	16
216.063.084.016	84	63	16
216.064.084.016	84	64	16

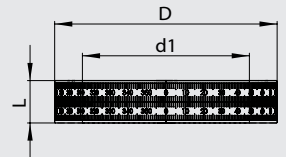

Ausdrehstahl-Verlängerungen

Boring bar extensions



Bestell-Nr. / Order number	D	d1	D2	L	L1
234.016.010.128	16	10	16	128	-
234.016.016.148	16	16	24	148	44

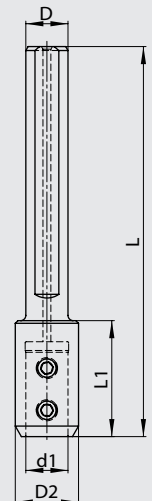

Schaft / shank Bestell-Nr. / Order number	D	L1	für Feinbohrkopf / for fine boring head
284.014.006.110	14	110	300.014.015.040
284.016.010.120	16	120	300.016.017.040
284.018.010.140	18	140	300.019.020.040



Stahlschaft

Steel shank

Schaft / shank Bestell-Nr. / Order number	D	L1	für Feinbohrkopf / for fine boring head
282.014.006.060	14	60	300.014.015.040
282.016.010.070	16	70	300.016.017.040
282.018.010.080	18	80	300.019.020.040

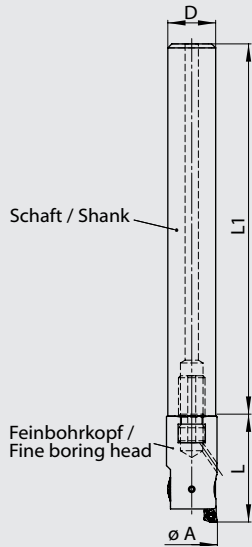

High-Speed Feinbohrköpfe

High-Speed fine boring heads

- Durchmessereinstellung mit geringstem Umkehrspiel
- Zustellgenauigkeit von 0.002mm über Nonius im Durchmesser
- mit Innenkühlung
- diametrical adjustment with maximal reduced reversal backlash
- 0.002mm diametrical adjustment by nonius
- with inner coolant supply

Feinbohrkopf / Fine boring head Bestell-Nr. / Order number	D	ø A min.	ø A max.	L	für Wendepaltenhalter / For insert holder (Wendepalte / Insert)
300.014.015.040	14	14.7	17.1	40	302.005.017.002 (WC..02 01..)
300.016.017.040	16	16.7	20.1	40	302.005.017.002 (WC..02 01..)
300.019.020.040	18	19.7	24.1	40	302.005.017.002 (WC..02 01..)

- Feinbohrkopf, Schaft und Wendepaltenhalter müssen separat bestellt werden
- fine boring head, shank and insert holder must be ordered separately

Ersatzteile / Zubehör

Spare parts / Accessories

300/301/304/305

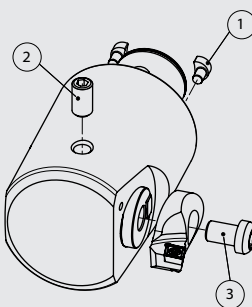

Für Feinbohrkopf For fine boring head	Bestell-Nr. / Order number	Bestell-Nr. / Order number	Bestell-Nr. / Order number
	Mitnehmer / Drive lug ①	Klemmschraube / Clamping screw ②	Befestigungsschraube / Fastening screw ③
300.014.015.040		900.881.280.140	900.882.280.140
300.016.017.040		900.881.280.160	900.882.280.160
300.019.020.040		900.881.280.180	900.288.280.180
300/301.020.024.041		900.304.004.003	900.314.004.006
300/301.025.031.045		900.304.005.004	900.314.005.008
300/301.032.040.051		900.304.006.005	900.314.006.010
304/305.020.024.035	900.102.020.000	900.304.004.003	900.314.004.006
304/305.025.031.040	900.102.025.000	900.304.005.004	900.314.005.008
304/305.032.040.047	900.102.032.000	900.304.006.005	900.314.006.010
304/305.039.051.057	900.102.039.000	900.304.008.006	900.314.008.012
304/305.050.067.080	900.102.050.000	900.304.010.010	900.314.010.016
304/305.064.087.100	900.102.064.000	900.304.010.018	900.314.010.016
304/305.090.116.130	900.102.090.000	900.304.010.030	900.314.010.016

Feinbohrköpfe zum Einschrauben

Fine boring heads with thread connection



- **Typ 300 (analog)** Zustellgenauigkeit von 0.002mm über Nonius im Durchmesser
- **Typ 301 (digital)** Einstellgenauigkeit 0.001mm im Durchmesser direktes Wegmeßsystem (kein Umkehrspiel)
- mit Innenkühlung

- **Type 300 (analog)** 0.002mm diametrical adjustment by nonius
- **Type 301 (digital)** 0.001 accuracy in diameter
- direct measurement system (no backlash)
- with inner coolant supply

Bestell-Nr. / Order number	$\varnothing A$ min.	$\varnothing A$ max.	d	L	Wendeplatten- halter / Insert holder
300/301.020.024.041	23.9	31.1	20	41	314.011.024.006
300/301.025.031.045	30.9	40.1	25	45	314.013.031.006
300/301.032.040.051	39.9	51.1	32	51	314.017.040.006

- Wendeplattenhalter müssen separat bestellt werden
- Anzeigeeinheit muss separat bestellt werden siehe Seite 6 (309.028.024.077).

- insert holders must be ordered separately
- Display unit must be ordered separately see page 6 (309.028.024.077).

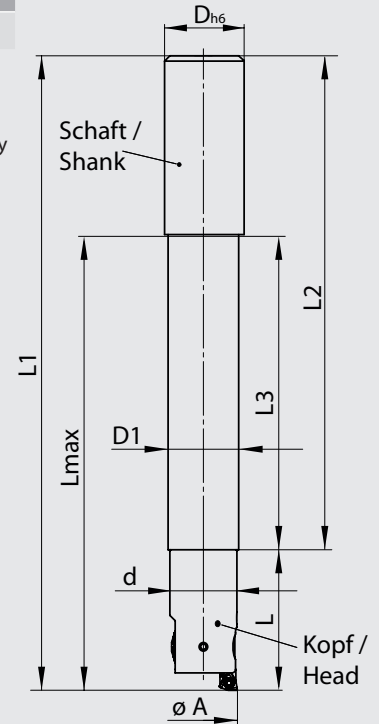

Schwingungsgedämpfte Vollhartmetallschäfte

Damped solid carbide shanks



- Produktivitätsgewinn dank der unterdrückten Schwingungen können die Schnittdaten beträchtlich erhöht werden
- Verbesserte Oberflächengüte
- Verbesserte Prozesssicherheit
- Verbesserte Spanabfuhr
- Reduzierte Kosten pro Bauteil
- Für Bohrungstiefen bis 12xD

- productivity improvement: thanks to reduced vibrations, the cutting conditions can be improved remarkable
- better surface quality
- improved process stability
- better chip evacuation
- reduced cost per part
- for boring length up to 12xD

Bestell-Nr. / Order number	D	D1	L max	L1	L2	L3	für Einschraubkopf / for screwable head
284.025.023.170	25	23	146	211	170	105	30x/400.020.024.041
284.025.023.220	25	23	196	261	220	155	30x/400.020.024.041
284.025.023.265	25	23	241	306	265	200	30x/400.020.024.041
284.032.029.220	32	29	200	265	220	155	30x/400.025.031.045
284.032.029.260	32	29	240	305	260	195	30x/400.025.031.045
284.032.029.310	32	29	290	355	310	245	30x/400.025.031.045
284.032.032.217	32	32	203	268	217	152	30x/400.032.040.051
284.032.032.287	32	32	273	338	287	222	30x/400.032.040.051
284.032.032.357	32	32	343	408	357	292	30x/400.032.040.051



Feinbohrköpfe Ø23.9-40.1

Fine boring heads Ø23.9-40.1

ECO LINE Uxx_F

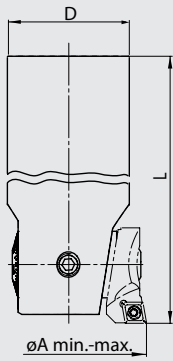

- Durchmessereinstellung mit geringstem Umkehrspiel
- Zustellgenauigkeit von 0.01mm resp. über Nonius 0.002mm im Durchmesser
- mit Innenkühlung

- diameter setting with minimal reversal backlash
- 0.01mm diametrical adjustment resp. 0.002mm by nonius
- with inner coolant supply

Bestell-Nr. / Order number	Ø D/ System	Ø A min.	Ø A max.	L	Wendeplattenhalter / Insert holder
U20_F20.K21.150	20	23.9	31.1	150	314.011.024.006 (CC.. 06 02 ..)
U25_F25.K21.170	25	30.9	40.1	170	314.013.031.006 (CC.. 06 02 ..)

- Werkzeug in einem Spannzangen- oder Hydrodehnfutter spannen.
- **inklusive Wendeplattenhalter**

- Clamp tool in a collet or hydraulic chuck.
- **insert holder included**



ECO LINE

Feinbohrköpfe Ø39.9-87.1

Fine boring heads Ø39.9-87.1

ECO LINE Exx_F

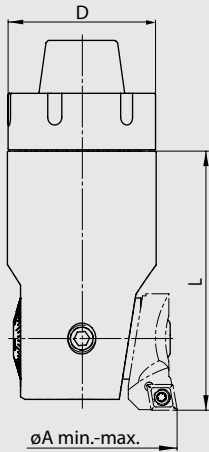

- Durchmessereinstellung mit geringstem Umkehrspiel
- Zustellgenauigkeit von 0.01mm resp. über Nonius 0.002mm im Durchmesser
- mit Innenkühlung

- diameter setting with minimal reversal backlash
- 0.01mm diametrical adjustment resp. 0.002mm by nonius
- with inner coolant supply

Bestell-Nr. / Order number	Ø D/ System	Ø A min.	Ø A max.	L	Wendeplattenhalter / Insert holder
E25_F32.K21.065	32 / ER25	39.9	51.1	65	314.017.040.006 (CC.. 06 02 ..)
E32_F42.K21.075	42 / ER32	50.9	67.1	75	314.022.051.006 (CC.. 06 02 ..)
E40_F55.K21.085	55 / ER40	66.9	87.1	85	314.030.067.009 (CC.. 09 T3 ..)

- Werkzeug in einem Spannzangenfutter spannen.
- **inklusive Wendeplattenhalter**

- Clamp tool in a collet chuck.
- **insert holder included**



ECO LINE

Feinbohrköpfe

Fine boring heads

304

- Durchmessereinstellung mit geringstem Umkehrspiel
- Zustellgenauigkeit von 0.01mm resp. über Nonius 0.002mm im Durchmesser
- mit Innenkühlung

- diametrical adjustment nearly without reversal backlash
- 0.01mm diametrical adjustment resp. 0.002mm by nonius
- with inner coolant supply

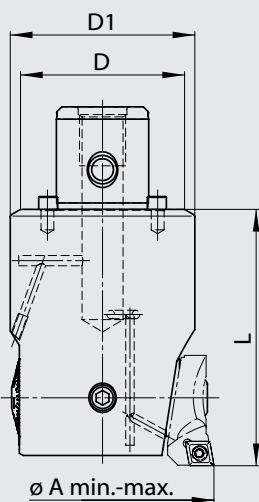

Bestell-Nr. / Order number	ø A min.	ø A max.	ST	D	D1	L	Wendeplattenhalter / Insert holder
304.020.024.035	23.9	31.1	ST1	20	20	35.5	314.011.024.006
	29.9	37.1					314.011.030.006
304.025.031.040	30.9	40.1	ST2	25	25	40	314.013.031.006
	37.9	47.1					314.013.038.006
304.032.040.047	39.9	51.1	ST3	32	32	47	314.017.040.006
	47.9	59.1					314.017.048.006
304.039.051.057	50.9	67.1	ST4	39	42	57	314.022.051.006
	64.9	81.1					314.022.065.006
304.050.067.080	66.9	87.1	ST5	50	55	80	314.030.067.009
	66.9	87.1					314.030.067.006
	84.9	105.1					314.030.085.006/9
304.064.087.100	86.9	116.1	ST6+	64	72	100	314.030.067.009
	86.9	116.1					314.030.067.006
	104.9	134.1					314.030.085.006/9
304.090.116.130	115.9	153.1	ST7+	90	94	130	314.030.067.009
	115.9	153.1					314.030.067.006
	133.9	171.1					314.030.085.006/9
	153.9	191.1					314.726.003.009
	165.9*	203.1*					

- Wendeplattenhalter müssen separat bestellt werden
- * Hinweis: Dieser Ausdrehbereich wird erreicht mit dem Wendeplattenhalter 314.726.003.009 in Kombination mit dem Distanzstück 900.803.001.006 (S.25).

- insert holders must be ordered separately
- * Note: For this diameter range the insert holder 314.726.003.009 and the adapter 900.803.001.006 is required (page 25).



Feinbohrköpfe DIGITAL

Fine boring heads DIGITAL

- Einstellgenauigkeit 0.001mm im Durchmesser
- direktes Wegmeßsystem (kein Umkehrspiel)
- keine Batterie und Auswerteelektronik im Werkzeug verbaut
- sehr einfache Bedienung
- digital und analog einsetzbar
- mit Innenkühlung

- 0.001 accuracy in diameter
- direct measurement system (no backlash)
- no battery and electronic evaluation unit inside the tool
- very easy operation
- for digital and analog use
- with inner coolant supply



Bestell-Nr. / Order number	ø A min.	ø A max.	ST	D	D1	L	Wendeplattenhalter / Insert holder
305.020.024.035	23.9	31.1	ST1	20	20	35.5	314.011.024.006
	29.9	37.1					314.011.030.006
305.025.031.040	30.9	40.1	ST2	25	25	40	314.013.031.006
	37.9	47.1					314.013.038.006
305.032.040.047	39.9	51.1	ST3	32	32	47	314.017.040.006
	47.9	59.1					314.017.048.006
305.039.051.057	50.9	67.1	ST4	39	42	57	314.022.051.006
	64.9	81.1					314.022.065.006
305.050.067.080	66.9	87.1	ST5	50	55	80	314.030.067.009
	66.9	87.1					314.030.067.006
305.064.087.100	84.9	105.1	ST6+	64	72	100	314.030.085.006/9
	86.9	116.1					314.030.067.009
305.090.116.130	86.9	116.1	ST7+	90	94	130	314.030.067.006
	104.9	134.1					314.030.085.006/9
305.090.116.130	115.9	153.1	ST7+	90	94	130	314.030.067.009
	115.9	153.1					314.030.067.006
	133.9	171.1					314.030.085.006/9
	153.9	191.1					314.726.003.009
	165.9*	203.1*					

- * Hinweis: Dieser Ausdrehbereich wird erreicht mit dem Wendeplattenhalter 314.726.003.009 in Kombination mit dem Distanzstück 900.803.001.006 (S.25)
- Anzeigeeinheit muss separat bestellt werden siehe Seite 6 (309.028.024.077).

- * Note: For this diameter range the insert holder 314.726.003.009 and the adapter 900.803.001.006 is required (page 25).
- Display unit must be ordered separately see page 6 (309.028.024.077).

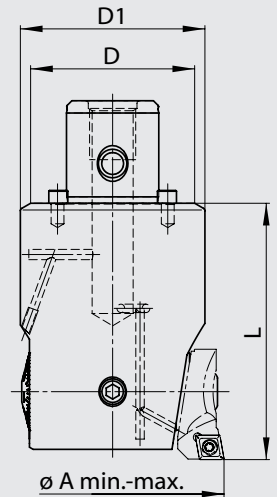

PSC FBHS

Feinbohrköpfe Ø23.9-153.1 DIGITAL

Fine boring heads Ø23.9-153.1 DIGITAL

- Einstellgenauigkeit 0.001mm im Durchmesser
- direktes Wegmeßsystem (kein Umkehrspiel)
- keine Batterie und Auswerteelektronik im Werkzeug verbaut
- sehr einfache Bedienung
- digital und analog einsetzbar
- mit Innenkühlung

- 0.001 accuracy in diameter
- direct measurement system (no backlash)
- no battery and electronic evaluation unit inside the tool
- very easy operation
- for digital and analog use
- with inner coolant supply



Bestell-Nr. / Order number	PSC / D	Ø A min.	Ø A max.	L	Wendeplattenhalter / Insert holder
PSC32-FBHS-DE-24	PSC 32 / 20	23.9	31.1	80	314.011.024.006 (CC.. 06 02 ..)
PSC32-FBHS-DE-31	PSC 32 / 25	30.9	40.1	90	314.013.031.006 (CC.. 06 02 ..)
PSC40-FBHS-DE-40	PSC 40 / 32	39.9	51.1	90	314.017.040.006 (CC.. 06 02 ..)
PSC50-FBHS-DE-51	PSC 50 / 42	50.9	67.1	90	314.022.051.006 (CC.. 06 02 ..)
PSC50-FBHS-DE-67	PSC 50 / 55	65.9	87.1	100	314.30.067.009 (CC.. 09 T3 ..)
PSC63-FBHS-DE-87	PSC 63 / 72	86.9	116.1	120	314.30.067.009 (CC.. 09 T3 ..)
PSC63-FBHS-DE-116	PSC 63 / 94	114.9	153.1	150	314.30.067.009 (CC.. 09 T3 ..)

- Wendeplattenhalter müssen separat bestellt werden
- Anzeigeeinheit muss separat bestellt werden siehe Seite 6 (309.028.024.077).

- insert holders must be ordered separately
- Display unit must be ordered separately see page 6 (309.028.024.077).

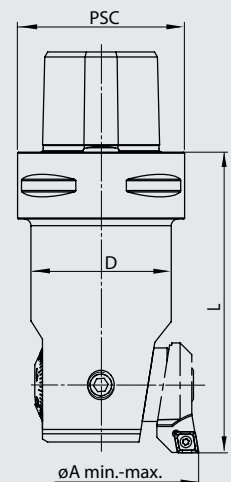

Wendeplattenhalter 90°

Insert holders 90°

• für die Verwendung in Feinbohrköpfen der Serie 304/305 und 590

• for use in fine boring heads from serie 304/305 and 590

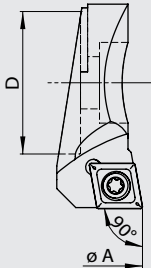

Bestell-Nr. / Order number	ø A min.	ø A max.	D	Wendeplatte / Insert	Feinbohrkopf / fine boring head
314.011.024.006	23.9	31.1	11	CC .. 06 02 ..	304/305.020.024.035
314.011.030.006	29.9	37.1	11	CC .. 06 02 ..	304/305.020.024.035
314.013.031.006	30.9	40.1	13	CC .. 06 02 ..	304/305.025.031.040
314.013.038.006	37.9	47.1	13	CC .. 06 02 ..	304/305.025.031.040
314.017.040.006	39.9	51.1	17	CC .. 06 02 ..	304/305.032.040.047
314.017.048.006	47.9	59.1	17	CC .. 06 02 ..	304/305.032.040.047
314.022.051.006	50.9	67.1	22	CC .. 06 02 ..	304/305.039.051.057
314.022.065.006	64.9	81.1	22	CC .. 06 02 ..	304/305.039.051.057
314.030.067.006	66.9	87.1	30	CC .. 06 02 ..	304/305.050.067.080
314.030.067.009	66.9	87.1	30	CC .. 09 T3 ..	304/305.050.067.080
314.030.085.006	84.9	105.1	30	CC .. 06 02 ..	304/305.050.067.080
314.030.085.009	84.9	105.1	30	CC .. 09 T3 ..	304/305.050.067.080
314.030.067.006	86.9	116.1	30	CC .. 06 02 ..	304/305.064.087.100
314.030.067.009	86.9	116.1	30	CC .. 09 T3 ..	304/305.064.087.100
314.030.085.006	104.9	134.1	30	CC .. 06 02 ..	304/305.064.087.100
314.030.085.009	104.9	134.1	30	CC .. 09 T3 ..	304/305.064.087.100
314.030.067.006	115.9	153.1	30	CC .. 06 02 ..	304/305.090.116.130
314.030.067.009	115.9	153.1	30	CC .. 09 T3 ..	304/305.090.116.130
314.030.085.006	133.9	171.1	30	CC .. 06 02 ..	304/305.090.116.130
314.030.085.009	133.9	171.1	30	CC .. 09 T3 ..	304/305.090.116.130
314.726.003.009	153.9	191.1	30	CC .. 09 T3 ..	304/305.090.116.130



Wendeplattenhalter 95°

Insert holders 95°

• für die Verwendung in Feinbohrköpfen der Serie 304/305 und 590

• for use in fine boring heads from serie 304/305 and 590

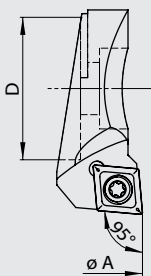

Bestell-Nr. / Order number	ø A min.	ø A max.	D	Wendeplatte / Insert	Feinbohrkopf / fine boring head
315.011.024.006	23.9	31.1	11	CC .. 06 02 ..	304/305.020.024.035
315.013.031.006	30.9	40.1	13	CC .. 06 02 ..	304/305.025.031.040
315.017.040.006	39.9	51.1	17	CC .. 06 02 ..	304/305.032.040.047
315.022.051.006	50.9	67.1	22	CC .. 06 02 ..	304/305.039.051.057
315.030.067.009	66.9	87.1	30	CC .. 09 T3 ..	304/305.050.067.080
315.030.067.009	86.9	116.1	30	CC .. 09 T3 ..	304/305.064.087.100
315.030.067.009	115.9	153.1	30	CC .. 09 T3 ..	304/305.090.116.130

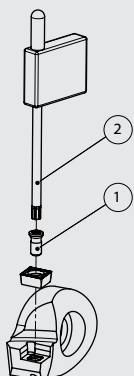

Ersatzteile / Zubehör

Spare parts / Accessories

302/314/315

Für Wendeplattenhalter For insert holder	Bestell-Nr. / Order number	Bestell-Nr. / Order number
	Torx-Schraube / Torx screw ①	Torx-Schlüssel / Torx driver ②
302.005.017.002	900.254.020.004	900.254.006.000
314/315.xxx.xxx.006	900.254.025.006	900.254.007.000
314/315.xxx.xxx.009	900.254.040.009	900.254.009.000

- für die Verwendung in Feinbohrköpfen der Serie 304/305 und 590/591

- for use in fine boring heads from serie 304/305 and 590/591



Bestell-Nr. / Order number	ø A min.	ø A max.	D	Wendeplatte / Insert	Feinbohrkopf / fine boring head
317.011.024.T07	23.9	31.1	11	TP .. 07 01 ..	304/305.020.024.035
317.011.030.T07	29.9	37.1	11	TP .. 07 01 ..	304/305.020.024.035
317.013.031.T07	30.9	40.1	13	TP .. 07 01 ..	304/305.025.031.040
317.013.038.T07	37.9	47.1	13	TP .. 07 01 ..	304/305.025.031.040
317.017.040.T07	39.9	51.1	17	TP .. 07 01 ..	304/305.032.040.047
317.017.048.T07	47.9	59.1	17	TP .. 07 01 ..	304/305.032.040.047
317.022.051.T07	50.9	67.1	22	TP .. 07 01 ..	304/305.039.051.057
317.022.065.T07	64.9	81.1	22	TP .. 07 01 ..	304/305.039.051.057
317.030.067.T11	66.9	87.1	30	TP .. 11 02 ..	304/305.050.067.080
317.030.085.T11	84.9	105.1	30	TP .. 11 02 ..	304/305.050.067.080
317.030.067.T11	86.9	116.1	30	TP .. 11 02 ..	304/305.064.087.100
317.030.085.T11	104.9	134.1	30	TP .. 11 02 ..	304/305.064.087.100
317.030.067.T11	115.9	153.1	30	TP .. 11 02 ..	304/305.090.116.130
317.030.085.T11	133.9	171.1	30	TP .. 11 02 ..	304/305.090.116.130
317.726.003.T11	153.9	191.1	30	TP .. 11 02 ..	304/305.090.116.130

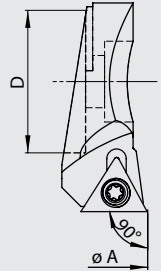

- für die Verwendung in Feinbohrköpfen der Serie 304/305 und 590/591

- for use in fine boring heads from serie 304/305 and 590/591



Bestell-Nr. / Order number	ø A min.	ø A max.	D	Wendeplatte / Insert	Feinbohrkopf / fine boring head
316.011.024.T06	23.9	31.1	11	TB .. 06 01 ..	304/305.020.024.035
316.013.031.T09	30.9	40.1	13	TP .. 09 02 ..	304/305.025.031.040
316.017.040.T09	39.9	51.1	17	TP .. 09 02 ..	304/305.032.040.047
316.022.051.T11	50.9	67.1	22	TP .. 11 03 ..	304/305.039.051.057
316.030.067.T11	66.9	87.1	30	TP .. 11 03 ..	304/305.050.067.080
316.030.085.T11	84.9	105.1	30	TP .. 11 03 ..	304/305.050.067.080
316.030.067.T11	86.9	116.1	30	TP .. 11 03 ..	304/305.064.087.100
316.030.085.T11	104.9	134.1	30	TP .. 11 03 ..	304/305.064.087.100
316.030.067.T11	115.9	153.1	30	TP .. 11 03 ..	304/305.090.116.130
316.030.085.T11	133.9	171.1	30	TP .. 11 03 ..	304/305.090.116.130

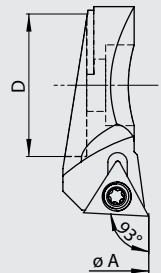

- für die Verwendung in Feinbohrköpfen der Serie 304
- damit können die Wendeplattenhalter der Serie 314 und 315 rückwärts montiert werden

- for use in fine boring heads from serie 304
- the insert holders from serie 314 and 315 will be fitted backwards on the adapter

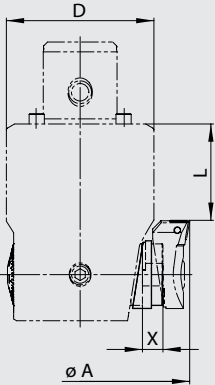

Bestell-Nr. / Order number	∅ A min.	∅ A max.	D	L	X	Feinbohrkopf / fine boring head
324.011.065.008	37	44	20	8.5	6.5	304.020.024.035
324.011.080.008	40	51	20	8.5	8.0	304.020.024.035
324.013.065.007	44	53	25	7.6	6.5	304.025.031.040
324.013.100.007	51	60	25	7.6	10.0	304.025.031.040
324.017.065.013	53	64	32	13.3	6.5	304.032.040.047
324.017.100.013	60	71	32	13.3	10.0	304.032.040.047
324.022.065.016	64	80	42	16.2	6.5	304.039.051.057
324.022.120.016	75	91	42	16.2	12.0	304.039.051.057
324.030.100.027	87	107	55	27.0	10.0	304.050.067.080
324.030.100.027	107	136	72	47.0	10.0	304.064.087.100
324.030.100.027	136	173	90	77.0	10.0	304.090.116.130



- Befestigungsschrauben werden mitgeliefert
- **Achtung: Linkslauf**

- fastening screws will be delivered with adapters
- **Caution: counterclockwise rotation**

**Einfahren
Enter into the bore**

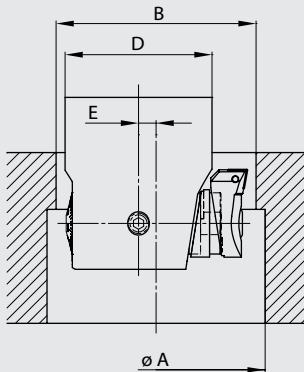

- **Minstdurchmesser der Eintrittsbohrung**
 $B = \frac{D + A}{2} - 1^*$
 - **Mindestversatz zum Einfahren**
 $E = \frac{A - B}{2} + 0.5^*$
- *Sicherheitsabstand

- **minimum entry bore diameter**
 $B = \frac{D + A}{2} - 1^*$
 - **minimum off centre to enter into the bore**
 $E = \frac{A - B}{2} + 0.5^*$
- *safety distance

**Rückwärtsbearbeitung
Back boring**

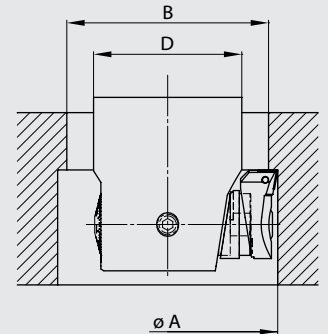

Ersatzteile / Zubehör

Spare parts / Accessories

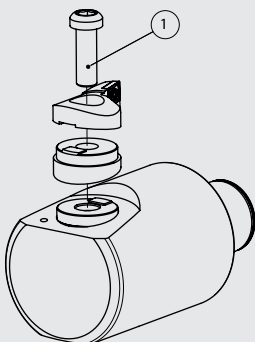

Für Umkehradapter For reversal adapter	Bestell-Nr. / Order number
	Befestigungsschraube / Fastening screw ①
324.011.065.008	900.324.004.012
324.011.080.008	900.324.004.013
324.013.065.007	900.324.005.014
324.013.100.007	900.324.005.016
324.017.065.013	900.324.006.015
324.017.100.013	900.324.006.020
324.022.065.016	900.324.008.020
324.022.120.016	900.324.008.025
324.030.100.027	900.324.010.030

- Durchmessereinstellung mit geringstem Umkehrspiel
- Zustellgenauigkeit von 0.01mm im Durchmesser
- mit Innenkühlung

- diametrical adjustment with maximal reduced reversal backlash
- 0.01mm diametrical adjustment
- with inner coolant supply



Bestell-Nr. / Order number	ø A min.	ø A max.	ST	D	D1	L
344.064.086.112	86	402	ST6+	64	80	112

- Wendeplattenhalter der Serie 354 müssen separat bestellt werden

- insert holders from serie 354 must be ordered separately

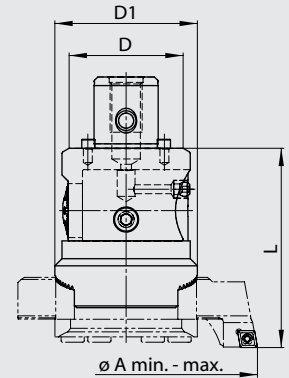

Wendeplattenhalter inkl. Druckplatte und Abstützung

Insert holders incl. clamp plate and support block



Bestell-Nr. / Order number	ø A min.	ø A max.	Wendeplatte / Insert
354.086.138.009	86	138	CC.. 09 T3..
354.086.138.012	86	138	CC.. 12 04..
354.136.220.009	136	220	CC.. 09 T3..
354.136.220.012	136	220	CC.. 12 04..
354.188.302.009	188	302	CC.. 09 T3..
354.242.402.009	242	402	CC.. 09 T3..

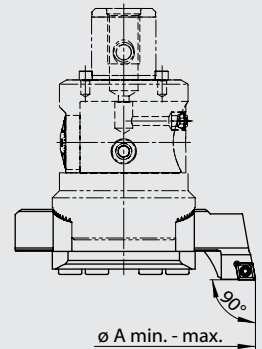

Ersatzteile / Zubehör

Spare parts / Accessories

344/354

Für Feinbohrkopf For fine boring head	Bestell-Nr. / Order number	Bestell-Nr. / Order number	Bestell-Nr. / Order number	Bestell-Nr. / Order number	Bestell-Nr. / Order number
	Mitnehmer / Drive lug ^①	Klemmschraube / Clamping screw ^②	Befestigungsschraube / Fastening screw ^③		
344.064.086.112	900.102.064.000	900.344.008.065	900.344.008.044		
Für Wendeplatten- haltersatz For insert holder set	Bestell-Nr. / Order number	Bestell-Nr. / Order number	Bestell-Nr. / Order number	Bestell-Nr. / Order number	Bestell-Nr. / Order number
	Wendeplattenhal- ter / Insert holder ^④	Abstützung / Support block ^⑤	Druckplatte / Clamp plate ^⑥	Torx-Schraube / Torx screw ^⑦	Torx-Schlüssel / Torx driver
354.086.138.009	900.354.086.009	900.345.020.086	900.345.010.086	900.254.040.009	900.254.009.000
354.086.138.012	900.354.086.012	900.345.020.086	900.345.010.086	900.254.050.010	900.254.012.000
354.136.220.009	900.354.136.009	900.345.020.136	900.345.010.136	900.254.040.009	900.254.009.000
354.136.220.012	900.354.136.012	900.345.020.136	900.345.010.136	900.254.050.010	900.254.012.000
354.188.302.009	900.354.188.009	900.345.020.136	900.345.010.136	900.254.040.009	900.254.009.000
354.242.402.009	900.354.242.009	900.345.020.136	900.345.010.136	900.254.040.009	900.254.009.000

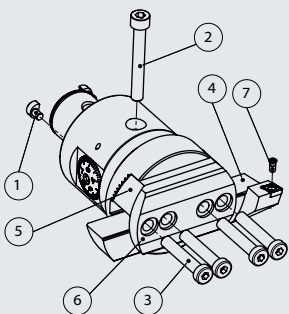

• mit Innenkühlung

• with inner coolant supply

Bestell-Nr. / Order number	ø A min.	ø A max.	d	L	Wendeplatten- halter / Insert holder
400.020.024.041	23.5	31.1	20	41	414.020.024.006 424.020.024.006 434.020.024.006 437.020.024.006
400.025.031.045	29.5	40.1	25	45	414.025.031.006 424.025.031.006 434.025.031.006 437.025.031.006
400.032.040.051	39.5	51.1	32	51	414.032.040.009 424.032.040.009 434.032.040.009 437.032.040.009



• Wendeplattenhalter müssen separat
bestellt werden

• insert holders must be ordered sepa-
rately

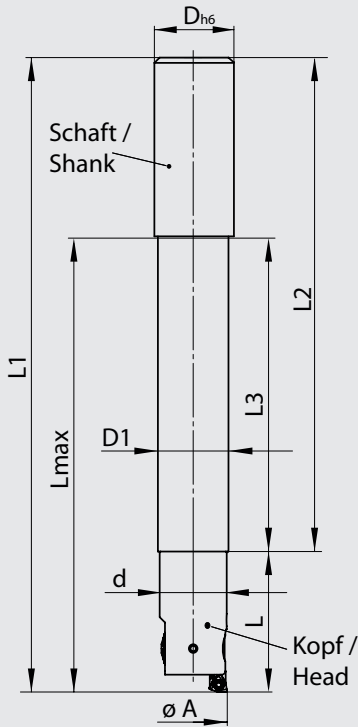

**Schwingungsgedämpfte
Vollhartmetallschäfte**

**Damped
solid carbide shanks**

- Produktivitätsgewinn dank der unterdrückten Schwingungen können die Schnittdaten beträchtlich erhöht werden
- Verbesserte Oberflächengüte
- Verbesserte Prozesssicherheit
- Verbesserte Spanabfuhr
- Reduzierte Kosten pro Bauteil
- Für Bohrungstiefen bis 12xD

- productivity improvement: thanks to reduced vibrations, the cutting conditions can be improved remarkable
- better surface quality
- improved process stability
- better chip evacuation
- reduced cost per part
- for boring length up to 12xD



Bestell-Nr. / Order number	D	D1	L max	L1	L2	L3	für Einschraubkopf / for screwable head
284.025.023.170	25	23	146	211	170	105	30x/400.020.024.041
284.025.023.220	25	23	196	261	220	155	30x/400.020.024.041
284.025.023.265	25	23	241	306	265	200	30x/400.020.024.041
284.032.029.220	32	29	200	265	220	155	30x/400.025.031.045
284.032.029.260	32	29	240	305	260	195	30x/400.025.031.045
284.032.029.310	32	29	290	355	310	245	30x/400.025.031.045
284.032.032.217	32	32	203	268	217	152	30x/400.032.040.051
284.032.032.287	32	32	273	338	287	222	30x/400.032.040.051
284.032.032.357	32	32	343	408	357	292	30x/400.032.040.051



Zweischneiderköpfe
Ø23.5-40.1Twin cutter boring heads
Ø23.5-40.1

ECO LINE



- mit Innenkühlung

- with inner coolant supply

Bestell-Nr. / Order number	ø A min.	ø A max.	Ø D/ System	L	Wendeplattenhalter / Insert holder
U20_Z20.K23.150	23.5	31.1	20	150	414.020.024.006 (CC.. 06 02 ..)
U25_Z25.K23.170	29.5	40.1	25	170	414.025.031.006 (CC.. 06 02 ..)

- Werkzeug in einem Spannzangen- oder Hydrodehnfutter spannen.
- **inklusive Wendeplattenhalter**

- Clamp tool in a collet or hydraulic chuck.
- **insert holder included**

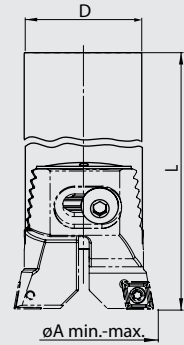
Zweischneiderköpfe
Ø65.5-87.1Twin cutter boring heads
Ø65.5-87.1

ECO LINE



- mit Innenkühlung

- with inner coolant supply

Bestell-Nr. / Order number	ø A min.	ø A max.	Ø D/ System	L	Wendeplattenhalter / Insert holder
E25_Z32.K23.065	39.5	50.1	32 / ER25	65	414.032.040.009 (CC.. 09 T3 ..)
E32_Z42.K23.075	49.5	67.1	42 / ER32	75	414.039.051.009 (CC.. 09 T3 ..)
E40_Z55.K23.085	65.5	87.1	55 / ER40	85	414.050.067.012 (CC.. 12 04 ..)

- Werkzeug in einem Spannzangenfutter spannen.
- **inklusive Wendeplattenhalter**

- Clamp tool in a collet chuck.
- **insert holder included**

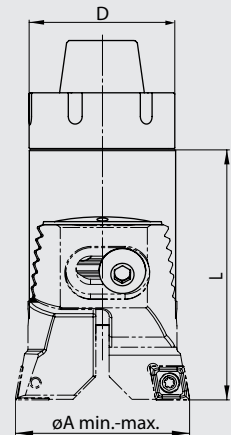

• mit Innenkühlung

• with inner coolant supply

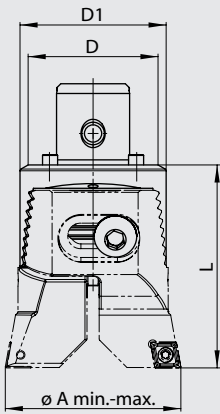

Bestell-Nr. / Order number	ø A min.	ø A max.	ST	D	D1	L	Wendeplattenhalter / Insert holder
404.020.024.035	23.5	31.1	ST1	20	20	35.5	414.020.024.006 424.020.024.006 434.020.024.006 437.020.024.006
404.025.031.040	29.5	40.1	ST2	25	25	40	414.025.031.006 424.025.031.006 434.025.031.006 437.025.031.006
404.032.040.047	39.5	51.1	ST3	32	32	47	414.032.040.009 424.032.040.009 434.032.040.009 437.032.040.009
404.039.051.057	49.5	67.1	ST4	39	42	57	414.039.051.009 424.039.051.009 434.039.051.009 437.039.051.009
404.050.067.080	65.5	87.1	ST5	50	55	80	414.050.067.012/112 424.050.067.012/112 434.050.067.012 437.050.067.012
404.064.087.100	86.5	116.1	ST6+	64	72	100	414.064.087.012/116 424.064.087.012/116 434.064.087.012 437.064.087.012
404.090.115.130	114.5	153.1	ST7+	90	94	130	414.090.115.012/116 424.090.115.116 434.090.115.012 437.090.115.012



• Wendeplattenhalter müssen separat bestellt werden

• insert holders must be ordered separately

Wendeplattenhalter 90°

Insert holders 90°

• für die Verwendung in Zweischneiderköpfen der Serie 404

• for use in twin cutter boring heads from serie 404

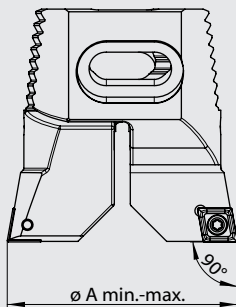

Bestell-Nr. / Order number	ø A min.	ø A max.	Wendeplatte / Insert	Zweischneiderkopf / twin cutter boring head
414.020.024.006	23.5	31.1	CC . .06 02 . .	404.020.024.035
414.025.031.006	29.5	40.1	CC . .06 02 . .	404.025.031.040
414.032.040.009	39.5	51.1	CC . .09 T3 . .	404.032.040.047
414.039.051.009	49.5	67.1	CC . .09 T3 . .	404.039.051.057
414.050.067.012	65.5	87.1	CC . .12 04 . .	404.050.067.080
414.050.067.112	65.5	87.5	CN . .12 04 . .	404.050.067.080
414.064.087.012	86.5	116.1	CC . .12 04 . .	404.064.087.100
414.064.087.116	86.5	116.1	CN . .16 06 . .	404.064.087.100
414.090.115.012	114.5	153.1	CC . .12 04 . .	404.090.115.130
414.090.115.116	114.5	153.1	CN . .16 06 . .	404.090.115.130



• Wendeplattenhalter werden paarweise geliefert

• insert holders will be supplied in pairs

Synchro-Wendeplattenhalter 90° Synchronised insert holders 90°

- für die Verwendung in Zweisechneiderköpfen der Serie 404
- mit der Synchrospindel können beide Wendeplattenhalter gleichzeitig symmetrisch eingestellt werden
- for use in twin cutter boring heads from serie 404
- with synchro spindle both insert holders can be adjusted synchronously and symmetrically



Bestell-Nr. / Order number	ø A min.	ø A max.	Wendeplatte / Insert	Zweisechneiderkopf / twin cutter boring head
434.020.024.006	23.5	31.1	CC .06 02 ..	404.020.024.035
434.025.031.006	29.5	40.1	CC .06 02 ..	404.025.031.040
434.032.040.009	39.5	51.1	CC .09 T3 ..	404.032.040.047
434.039.051.009	49.5	67.1	CC .09 T3 ..	404.039.051.057
434.050.067.012	65.5	87.1	CC .12 04 ..	404.050.067.080
434.064.087.012	86.5	116.1	CC .12 04 ..	404.064.087.100
434.090.115.012	114.5	153.1	CC .12 04 ..	404.090.115.130

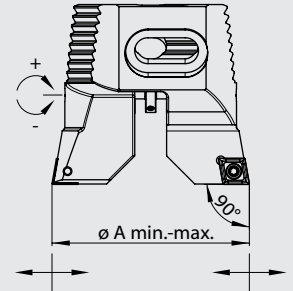

- Wendeplattenhalter werden paarweise geliefert
- insert holders will be supplied in pairs

Wendeplattenhalter 70° Insert holders 70°

- für die Verwendung in Zweisechneiderköpfen der Serie 404
- for use in twin cutter boring heads from serie 404



Bestell-Nr. / Order number	ø A min.	ø A max.	Wendeplatte / Insert	Zweisechneiderkopf / twin cutter boring head
424.020.024.006	23.5	31.1	CC .06 02 ..	404.020.024.035
424.025.031.006	29.5	40.1	CC .06 02 ..	404.025.031.040
424.032.040.009	39.5	51.1	CC .09 T3 ..	404.032.040.047
424.039.051.009	49.5	67.1	CC .09 T3 ..	404.039.051.057
424.050.067.012	65.5	87.1	CC .12 04 ..	404.050.067.080
424.050.067.112	65.5	87.1	CN .12 04 ..	404.050.067.080
424.064.087.012	86.5	116.1	CC .12 04 ..	404.064.087.100
424.064.087.116	86.5	116.1	CN .16 06 ..	404.064.087.100
424.090.115.116	114.5	153.1	CN .16 06 ..	404.090.115.130

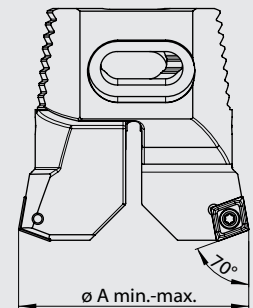

- Wendeplattenhalter werden paarweise geliefert
- insert holders will be supplied in pairs

Wendeplattenhalter 90° axial 0.4mm zurückgesetzt Insert holders 90° axial 0.4mm staggered

- für die Verwendung in Zweisechneiderköpfen der Serie 404
- zur Schnittaufteilung bei grosser Spantiefe
- for use in twin cutter boring heads from serie 404
- for divided cut



Bestell-Nr. / Order number	ø A min.	ø A max.	Wendeplatte / Insert	Zweisechneiderkopf / twin cutter boring head
437.020.024.006	23.5	31.1	CC .06 02 ..	404.020.024.035
437.025.031.006	29.5	40.1	CC .06 02 ..	404.025.031.040
437.032.040.009	39.5	51.1	CC .09 T3 ..	404.032.040.047
437.039.051.009	49.5	67.1	CC .09 T3 ..	404.039.051.057
437.050.067.012	65.5	87.1	CC .12 04 ..	404.050.067.080
437.064.087.012	86.5	116.1	CC .12 04 ..	404.064.087.100
437.090.115.012	114.5	153.1	CC .12 04 ..	404.090.115.130

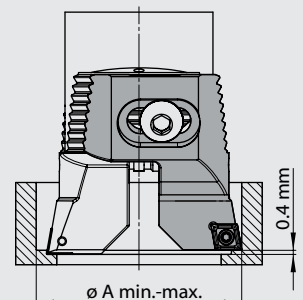

- Wendeplattenhalter werden paarweise geliefert
- insert holders will be supplied in pairs

• mit Innenkühlung

• with inner coolant supply

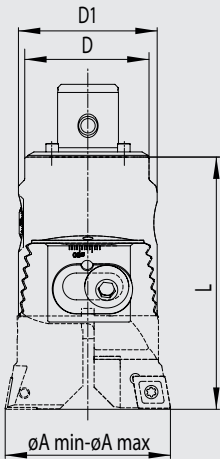

Bestell-Nr. / Order number	$\varnothing A$ min.	$\varnothing A$ max.	ST	D	D1	L	Wendeplatte / Insert
464.025.031.055	29.5	40.1	ST2	25	25	55	474.025.031.006
464.032.040.065	39.5	50.5	ST3	32	32	65	474.032.040.009
464.039.051.082	49.5	66.5	ST4	39	42	82	474.039.051.009
464.050.067.100	65.5	87.5	ST5	50	55	100	474.050.067.012
464.064.087.125	86.5	115.5	ST6+	64	72	125	474.064.087.012

• Wendeplattenhalter müssen separat
bestellt werden

• insert holders must be ordered sepa-
rately



• für die Verwendung in Zweischneider-
köpfen der Serie 464

• for use in twin cutter boring heads
from serie 464

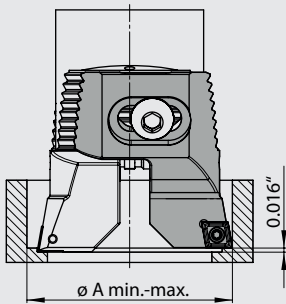

Bestell-Nr. / Order number	$\varnothing A$ min.	$\varnothing A$ max.	Insert	Zweischneiderkopf / twin cutter boring head
474.025.031.006	29.5	40.1	CC . .06 02 . .	464.025.031.055
474.032.040.009	39.5	51.1	CC . .09 T3 . .	464.032.040.065
474.039.051.009	49.5	67.1	CC . .09 T3 . .	464.039.051.082
474.050.067.012	65.5	87.1	CC . .12 04 . .	464.050.067.100
474.064.087.012	86.5	116.1	CC . .12 04 . .	464.064.087.125



- Einfache, kostengünstige Ausführung
- Brücke wird auf einen Fräsdorn Ø32 gespannt
- Modular aufgebaut und verlängerbar für grosse Zapfenlängen
- mit innerer Kühlmittelzuführung
- Auch zum Ausdrehen von Bohrungen geeignet

- simple and cost effective solution
- bridge is assembled on a milling arbor Ø32
- modular construction, extendable for long work pieces
- with inner coolant supply
- suitable for boring operations

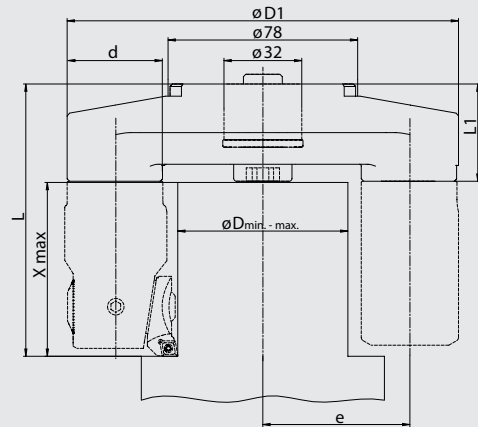

Bestell-Nr./ Order number	ø D min.	ø D max.	d	e	D1	L1	X* max	L*
561.032.032.099	15.9	27.1	32	33.5	99	40	46.5 (76.5)	86.5 (116.5)
561.032.032.110	26.9	38.1	32	39.0	110	40	46.5 (76.5)	86.5 (116.5)
561.039.032.145	37.9	54.1	39	52.5	145	40	56.5 (96.5)	96.5 (136.5)
561.039.032.161	53.9	70.1	39	60.5	161	40	56.5 (96.5)	96.5 (136.5)
561.050.032.207	69.9	90.1	50	78.5	207	45	79.5 (139.5)	124.5 (184.5)
561.050.032.227	89.9	110.1	50	88.5	227	45	79.5 (139.5)	124.5 (184.5)

- *) Die Werte in Klammern zeigen die Werkzeuglänge und max. Zapfenlänge unter Verwendung der entsprechenden Verlängerungen.
- Gegengewicht und Spanschraube im Lieferumfang enthalten. Feinbohrkopf oder Zweischneiderkopf muss separat bestellt werden

- *) The values in brackets indicate the tool length and the max. pin length with the use of the corresponding extensions.
- Counter weight and clamping screw included. Fine boring head or twin cutter must be ordered separately.

Werkzeugauswahl

Tool selection



- Schlichten

- Finishing

Werkzeughalter / Toolholder	Feinbohrkopf / Fine boring head	Plattenhalter / Insert holder	ø D min.	ø D max.	Gegengewicht / Counter weight
561.032.032.099	304.032.040.047	314.017.040.006	15.9	27.1	595.032.032.038
561.032.032.110	304.032.040.047	314.017.040.006	26.9	38.1	595.032.032.038
561.039.032.145	304.039.051.057	314.022.051.006	37.9	54.1	595.039.042.053
561.039.032.161	304.039.051.057	314.022.051.006	53.9	70.1	595.039.042.053
561.050.032.207	304.050.067.080	314.030.067.009	69.9	90.1	595.050.055.071
561.050.032.227	304.050.067.080	314.030.067.009	89.9	110.1	595.050.055.071

Werkzeugauswahl

Tool selection



- Schruppen

- Roughing

Werkzeughalter / Toolholder	Schruppkopf / Roughing head	Plattenhalter / Insert holder	ø D min.	ø D max.
561.032.032.099	404.032.040.047	414.032.040.009	15.9	27.1
561.032.032.110	404.032.040.047	414.032.040.009	26.9	38.1
561.039.032.145	404.039.051.057	414.039.051.009	37.9	54.1
561.039.032.161	404.039.051.057	414.039.051.009	53.9	70.1
561.050.032.207	404.050.067.080	414.050.067.012/112	69.9	90.1
561.050.032.227	404.050.067.080	414.050.067.012/112	89.9	110.1

Zapfenbearbeitung

Pin turning

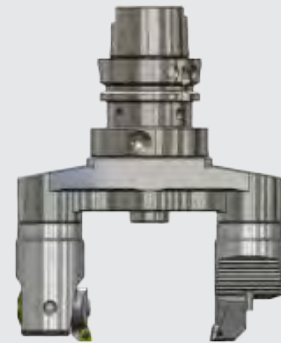
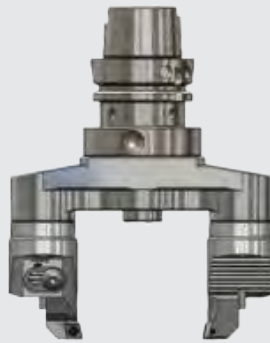
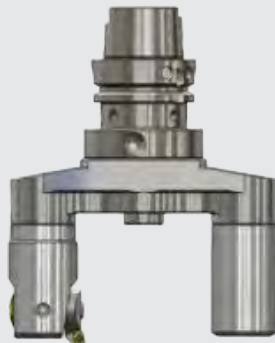

- **Achtung:** Spindel linksdrehend!
Vc max. 450 m/min

- **Attention:** Counter clockwise spindle rotation
Vc max. 450 m/min

Ersatzteile / Zubehör

Spare parts / Accessories

404/464

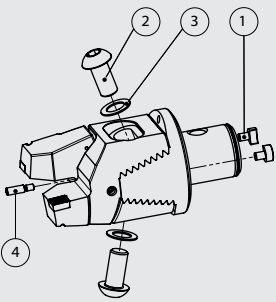

Für Zweischneider-kopf For twin cutter boring head	Bestell-Nr. / Order number	Bestell-Nr. / Order number	Bestell-Nr. / Order number	Bestell-Nr. / Order number
	Mitnehmer / Drive lug (1)	Befestigungsschraube / Fastening screw (2)	Federring / Spring washer (3)	Anschlag / Stopper (4)
404.020.024.035	900.102.020.000	900.404.004.008	900.405.004.000	900.406.025.008
404/464.025.031.040	900.102.025.000	900.404.005.012	900.405.005.000	900.406.025.008
404/464.032.040.047	900.102.032.000	900.404.006.016	900.405.006.000	900.406.030.012
404/464.039.051.057	900.102.039.000	900.404.008.020	900.405.008.000	900.406.030.014
404/464.050.067.080	900.102.050.000	900.404.010.025	900.405.010.000	900.406.040.020
404/464.064.087.100	900.102.064.000	900.404.012.025	900.405.012.000	900.406.060.020
404.090.116.130	900.102.090.000	900.404.016.035	900.405.016.000	900.406.060.020

Ersatzteile / Zubehör

Spare parts / Accessories

414/424/437/474

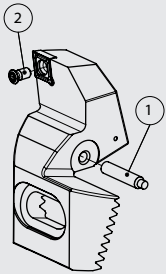

Für Wendeplattenhalter For insert holder	Bestell-Nr. / Order number	Bestell-Nr. / Order number	Bestell-Nr. / Order number
	Einstellschraube / Adjustment screw (1)	Torx-Schraube / Torx screw (2)	Torx-Schlüssel / Torx driver
414/424/437.020.024.006	900.414.004.007	900.254.025.006	900.254.007.000
414/424/437/474.025.031.006	900.414.004.010	900.254.025.006	900.254.007.000
414/424/437/474.032.040.009	900.414.004.013	900.254.040.009	900.254.009.000
414/424/437/474.039.051.009	900.414.006.014	900.254.040.009	900.254.009.000
414/424/437/474.050.067.xxx	900.415.006.020	900.254.050.010	900.254.012.000
414/424/437/474.064.087.xxx	900.415.006.030	900.254.050.010	900.254.012.000
414/424/437/474.090.115.xxx	900.415.006.040	900.254.050.010	900.254.012.000

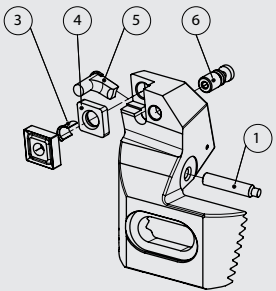

Für Wendeplattenhalter For insert holder	Bestell-Nr. / Order number	Bestell-Nr. / Order number	Bestell-Nr. / Order number	Bestell-Nr. / Order number
	Rohrstift / Hollow pin (3)	Zwischenlage / Tip pad (4)	Kniehebel / Lever (5)	Schraube zu Kniehebel / Lever screw (6)
414/424.050.067.112	900.416.012.000	900.417.012.000	900.418.012.000	900.419.012.000
414/424.064.087.116	900.416.016.000	900.417.016.000	900.418.016.000	900.419.016.000
414/424.090.115.116	900.416.016.000	900.417.016.000	900.418.016.000	900.419.016.000

Ersatzteile / Zubehör

Spare parts / Accessories

434

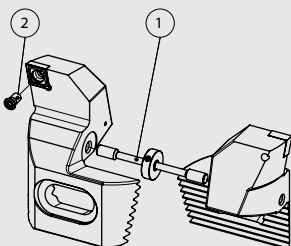

Für Wendeplattenhalter For insert holder	Bestell-Nr. / Order number	Bestell-Nr. / Order number	Bestell-Nr. / Order number
	Einstellschraube / Adjustment screw (1)	Torx-Schraube / Torx screw (2)	Torx-Schlüssel / Torx driver
434.020.024.006	900.434.004.018	900.254.025.006	900.254.007.000
434.025.031.006	900.434.004.023	900.254.025.006	900.254.007.000
434.032.040.009	900.434.004.030	900.254.040.009	900.254.009.000
434.039.051.009	900.434.006.040	900.254.040.009	900.254.009.000
434.050.067.012	900.434.006.052	900.254.050.010	900.254.012.000
434.064.087.012	900.434.006.068	900.254.050.010	900.254.012.000
434.090.115.012	900.434.006.090	900.254.050.010	900.254.012.000

• mit Innenkühlung

• with inner coolant supply

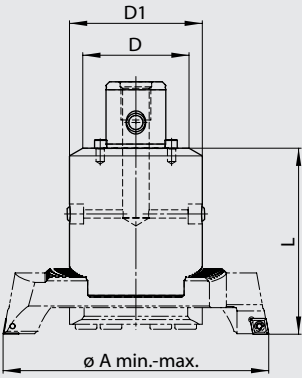

Bestell-Nr. / Order number	ø A min.	ø A max.	ST	D	D1	L
444.064.086.112	68	402	ST6+	64	80	112

• Wendeplattenhalter der Serie 454 müs-
sen separat bestellt werden

• insert holders from serie 454 must be
ordered separately



**Wendeplattenhalterpaare
inkl. Druckplatte**

**Insert holder pairs
incl. clamp plate**

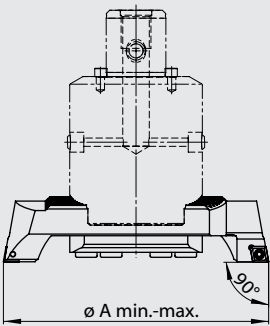

Bestell-Nr. / Order number	ø A min.	ø A max.	Wendeplatte / Insert
454.086.138.009	86	138	CC.. 09 T3 ..
454.086.138.012	86	138	CC.. 12 04 ..
454.136.220.009	136	220	CC.. 09 T3 ..
454.136.220.012	136	220	CC.. 12 04 ..
454.188.302.009	188	302	CC.. 09 T3 ..
454.242.402.009	242	402	CC.. 09 T3 ..



Ersatzteile / Zubehör

Spare parts / Accessories

Für Zweischneiderkopf For twin cutter boring head	Bestell-Nr. / Order number	Bestell-Nr. / Order number	Bestell-Nr. / Order number	Bestell-Nr. / Order number
	Mitnehmer / Drive lug ^①	Befestigungsschraube / Fastening screw ^②		
444.064.086.112	900.102.064.000	900.344.008.044		
Für Wendeplatten- haltersatz For insert holder set	Bestell-Nr. / Order number	Bestell-Nr. / Order number	Bestell-Nr. / Order number	Bestell-Nr. / Order number
	Wendeplattenhal- ter / Insert holder ^③	Druckplatte / Clamp plate ^④	Torx-Schraube / Torx screw ^⑤	Torx-Schlüssel / Torx driver
454.086.138.009	900.354.086.009	900.345.010.086	900.254.040.009	900.254.009.000
454.086.138.012	900.354.086.012	900.345.010.086	900.254.050.010	900.254.012.000
454.136.220.009	900.354.136.009	900.345.010.136	900.254.040.009	900.254.009.000
454.136.220.012	900.354.136.012	900.345.010.136	900.254.050.010	900.254.012.000
454.188.302.009	900.354.188.009	900.345.010.136	900.254.040.009	900.254.009.000
454.242.402.009	900.354.242.009	900.345.010.136	900.254.040.009	900.254.009.000

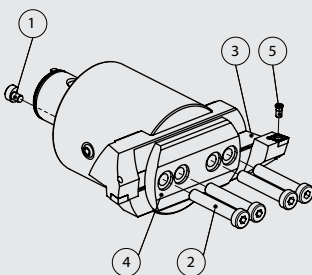

Feinbohrbrückenwerkzeuge Ø85.5-650.1

Fine boring bridges tools Ø85.5-650.1

- DurchmesserEinstellung mit geringstem Umkehrspiel
- Zustellgenauigkeit von 0.01mm im Durchmesser
- mit Innenkühlung
- diameter setting with minimal reversal backlash
- 0.01 mm diametrical adjustment
- with inner coolant supply



Bestell-Nr. / Order number	Ø D / System	Ø A min.	Ø A max.	L	Feinbohraufsatz / Fine bore adapter
D32_F01.085.098	78 / D32	85.5	140.1	98	F01_WCA.B11.050 (CC.. 06 02 ..)
D32_F02.139.098	78 / D32	139.5	220.1	98	F02_WCA.B11.050 (CC.. 06 02 ..)
D32_F02.219.098	78 / D32	219.5	310.1	98	F02_WCA.B11.050 (CC.. 06 02 ..)
D40_F02.309.108	88 / D40	309.5	395.1	108	F02_WCA.B11.050 (CC.. 06 02 ..)
D40_F02.394.108	88 / D40	394.5	480.1	108	F02_WCA.B11.050 (CC.. 06 02 ..)
D60_F02.479.118	128 / D60	479.5	565.1	118	F02_WCA.B11.050 (CC.. 06 02 ..)
D60_F02.564.118	128 / D60	564.5	650.1	118	F02_WCA.B11.050 (CC.. 06 02 ..)

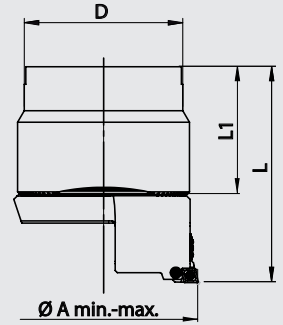

- Werkzeug in einer Fräsdorn- oder Messerkopfaufnahme spannen.
- **inklusive Feinbohraufsatz (F01/F02)**
- Clamp tool in a shell mill holder.
- **Fine boring adapter included (F01/ F02)**

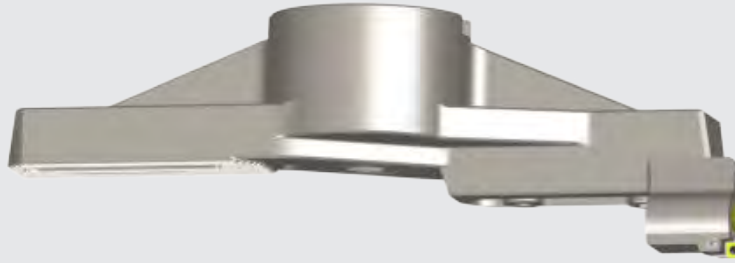

ECO LINE

Zweischneiderbrückenwerk- zeuge Ø85.5-650.1

Twin cutter bridge tools Ø85.5

- mit Innenkühlung
- with inner coolant supply

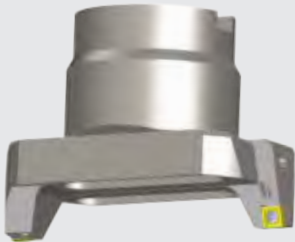

Bestell-Nr. / Order number	Ø D / System	Ø A min.	Ø A max.	L	Wendeplattenhalter / Insert holder
D32_Z01.085.098	78 / D32	85.5	140.1	98	Z01_WCC.B11.050 (CC.. 12 04 ..)
D32_Z02.139.098	78 / D32	139.5	220.1	98	Z02_WCC.B11.050 (CC.. 12 04 ..)
D32_Z02.219.098	78 / D32	219.5	310.1	98	Z02_WCC.B11.050 (CC.. 12 04 ..)
D40_Z02.309.108	88 / D40	309.5	395.1	108	Z02_WCC.B11.050 (CC.. 12 04 ..)
D40_Z02.394.108	88 / D40	394.5	480.1	108	Z02_WCC.B11.050 (CC.. 12 04 ..)
D60_Z02.479.118	128 / D60	479.5	565.1	118	Z02_WCC.B11.050 (CC.. 12 04 ..)
D60_Z02.564.118	128 / D60	564.5	650.1	118	Z02_WCC.B11.050 (CC.. 12 04 ..)

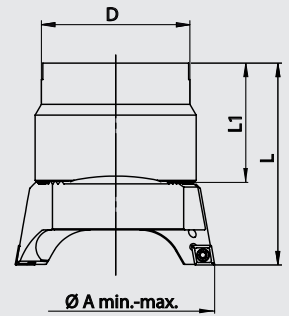

- Werkzeug in einer Fräsdorn- oder Messerkopfaufnahme spannen.
- **inklusive Wendeplattenhalter (Z01/Z02)**
- Clamp tool in a shell mill holder.
- **insert holder included (Z01/Z02)**

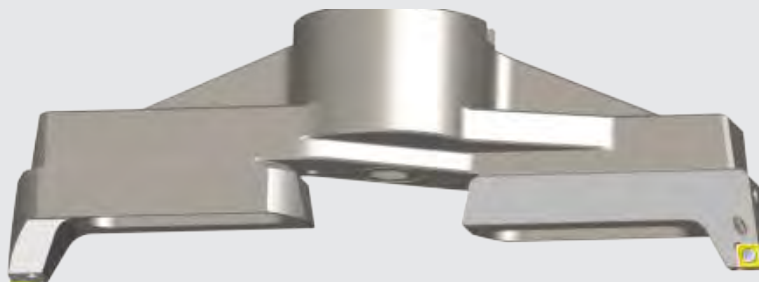

ECO LINE

Aufnahmen mit Konsole

Master shanks with bridge adapter

504 / 514 / 534 / 544

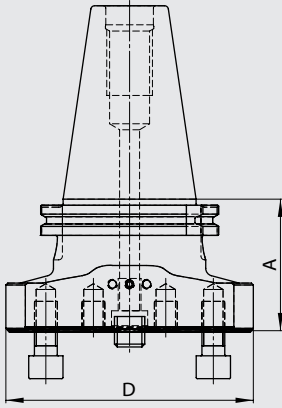

• ANSI B5.50

Bestell-Nr. / Order number	CAT	D	A
504.340.130.069	40	130	69.1
504.350.130.069	50	130	69.1

• DIN 69871 A/D

Bestell-Nr. / Order number	ISO	D	A
514.440.130.069	40	130	69.1
514.450.130.069	50	130	69.1

• MAS BT 403

Bestell-Nr. / Order number	BT	D	A
534.540.130.077	40	130	77
534.550.130.088	50	130	88

• DIN 69893 HSK A

Bestell-Nr. / Order number	HSK A	D	A
544.806.130.075	63	130	77
544.810.130.075	100	130	88

• Kühlmittelset muss separat bestellt werden 900.500.028.015

• ANSI B5.50

• DIN 69871 A/D

• MAS BT 403

• DIN 69893 HSK A

• cooling set must be ordered separately 900.500.028.015

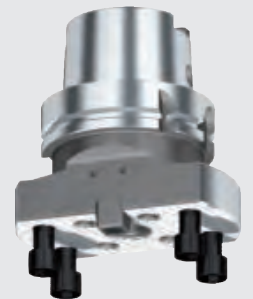
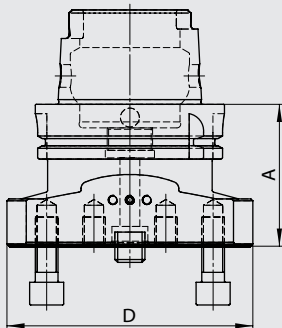

Zwischenkonsolen

Bridge adapters

554

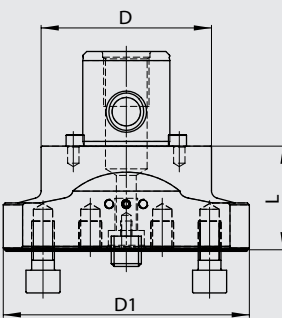

Bestell-Nr. / Order number	ST	D	D1	L
554.064.130.055	ST6+	64	130	55
554.090.130.055	ST7+	90	130	55

• Kühlmittelset muss separat bestellt werden 900.500.028.015

• cooling set must be ordered separately 900.500.028.015

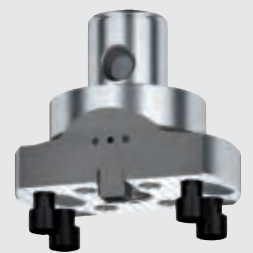

Ersatzteile / Zubehör

Spare parts / Accessories

504/514/534/544/554

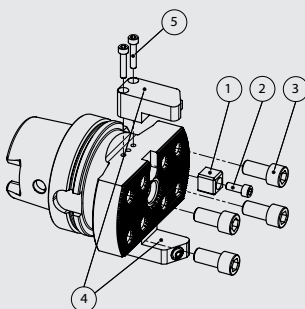

Für Konsole For bridge adapter	Bestell-Nr. / Order number	Bestell-Nr. / Order number	Bestell-Nr. / Order number
	Mitnehmerstein / Drive lug ①	Schraube / Screw ②	Befestigungsschraube / Fastening screw ③
504-554	900.514.016.016	900.515.006.015	900.516.012.025
	Kühlmittelset / Cooling set ④	Befestigungsschraube / Fastening screw ⑤	
504-554	900.500.028.015	900.500.005.025	

- für die Verwendung auf Konsolen der Serien 504 bis 554

- for use on bridge adapters from series 504 to 554



Bestell-Nr. / Order number	D	L	Ausrehdurchmesser / Boring diameter
560.130.130.030	130	30	150 – 205
560.130.180.030	180	30	200 – 255
560.130.230.035	230	35	250 – 305
560.130.280.035	280	35	300 – 355
560.130.330.040	330	40	350 – 405
560.130.380.040	380	40	400 – 455
560.130.430.040	430	40	450 – 505
560.130.480.040	480	40	500 – 555
560.130.530.050	530	50	550 – 605
560.130.580.050	580	50	600 – 655

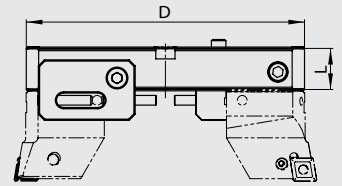

Einstellplatte / Adjustment plate Bestell-Nr. / Order number	Für Verlängerungskonsole / For extensions bridge	D
900.561.080.012	560.130.180.030	10 - 65
900.561.080.012	560.130.230.035	60 - 115
900.561.080.012	560.130.280.035	110 - 165
900.561.080.012	560.130.330.040	160 - 215
900.561.080.012	560.130.380.040	210 - 265
900.561.080.012	560.130.430.040	260 - 315
900.561.080.012	560.130.480.040	310 - 365
900.561.080.012	560.130.530.050	360 - 415
900.561.080.012	560.130.580.050	410 - 465

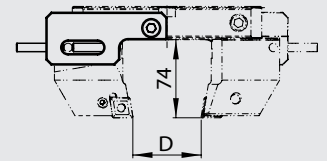

Ersatzteile / Zubehör

Spare parts / Accessories

560/562/564

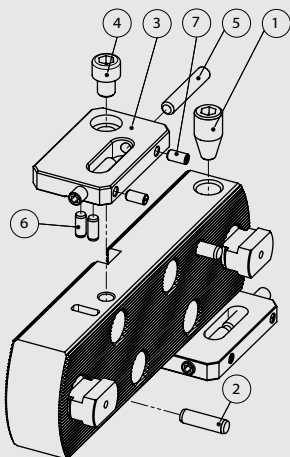

Für Verlängerungskonsole / Schieber	Bestell-Nr. / Order number	Bestell-Nr. / Order number	Bestell-Nr. / Order number	Bestell-Nr. / Order number
For extension bridge / Slider	Klemmschr. / Clamping screw ①	Stift / Pin ②		Feststellschraube / Tightening screw ⑦
560 / 564	900.560.016.030	900.560.008.028		900.560.006.012
Für Verlängerungskonsole / Schieber	Bestell-Nr. / Order number	Bestell-Nr. / Order number	Bestell-Nr. / Order number	Bestell-Nr. / Order number
For extension bridge / Slider	Einstellplatte / Adjustment plate ③	Schraube / Screw ④	Einstellschraube / Adjustment screw ⑤	Stift / Pin ⑥
560.130.130/230.030	900.560.080.012	900.560.110.012	900.560.008.045	900.560.006.014
560.130.180/280-580.xxx	900.560.080.012	900.560.110.018	900.560.008.045	900.560.006.014
564.000.xxx.048	900.560.080.012	900.560.110.018	900.560.008.045	900.560.006.014
Für Basis For basis	Bestell-Nr. / Order number	Bestell-Nr. / Order number		Bestell-Nr. / Order number
	Zentrierbuchse / Centering sleeve	Schraube m. U-Scheibe / Screw w. washer		Unterlage / Mat
562.060.xxx.080	900.562.018.012	900.562.012.080		900.562.138.005

Wendeplattenhalter 90°

Insert holder 90°

570

- für die Verwendung auf Verlängerungskonsolen der Serien 560 und 564

- for use on extension bridges from series 560 and 564

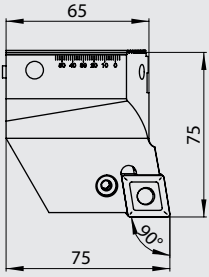

Bestell-Nr. / Order number	Wendeplatte / Insert
570.070.009.075	CC .. 09 T3 ..
570.070.012.075	CN .. 12 04 ..
570.070.019.075	CN .. 19 06 ..



- Wendeplattenhalter werden paarweise geliefert

- insert holders will be supplied in pairs

Wendeplattenhalter 90° axial 1.0mm zurückgesetzt

Insert holder 90° axial 1.0mm staggered

575

- für die Verwendung auf Verlängerungskonsolen der Serien 560 und 564

- for use on extension bridges from series 560 and 564



Bestell-Nr. / Order number	Wendeplatte / Insert
575.070.009.074	CC .. 09 T3 ..
575.070.012.074	CN .. 12 04 ..
575.070.019.074	CN .. 19 06 ..



- Wendeplattenhalter werden paarweise geliefert

- insert holders will be supplied in pairs

Wendeplattenhalter 70°

Insert holder 70°

580

- für die Verwendung auf Verlängerungskonsolen der Serien 560 und 564

- for use on extension bridges from series 560 and 564

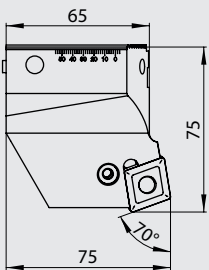

Bestell-Nr. / Order number	Wendeplatte / Insert
580.070.019.075	CN .. 19 06 ..



- Wendeplattenhalter werden paarweise geliefert

- insert holders will be supplied in pairs

Ersatzteile / Zubehör

Spare parts / Accessories

570/575/580

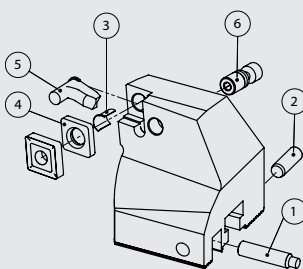

Für Wendeplattenhalter	Bestell-Nr. / Order number	Bestell-Nr. / Order number	Bestell-Nr. / Order number	Bestell-Nr. / Order number
For insert holder	Einstellschraube / Adjustment screw	Stift / Pin	Torx-Schraube / Torx screw	Torx-Schlüssel / Torx driver
570/575.070.009.075/074	900.570.008.035	900.570.008.024	900.254.040.009	900.254.009.000
570/575.070.012.075/074	900.570.008.035	900.570.008.024		
570/575.070.019.075/074	900.570.008.035	900.570.008.024		
580.070.019.075	900.570.008.035	900.570.008.024		
Für Wendeplattenhalter	Bestell-Nr. / Order number	Bestell-Nr. / Order number	Bestell-Nr. / Order number	Bestell-Nr. / Order number
For insert holder	Rohrstift / Hollow pin	Zwischenlage / Tip pad	Kniehebel / Lever	Schraube zu Kniehebel / Lever screw
570.070.012.075	900.416.012.000	900.417.012.000	900.418.012.000	900.419.012.000
570.070.019.075	900.416.019.000	900.417.019.000	900.418.019.000	900.419.019.000
580.070.019.075	900.416.019.000	900.417.019.000	900.418.019.000	900.419.019.000



- für die Verwendung auf Verlängerungskonsolen der Serien 560 und 564
- DurchmesserEinstellung mit geringstem Umkehrspiel
- Zustellgenauigkeit von 0.002mm über Nonius im Durchmesser

- for use on extension bridges from series 560 and 564
- diametrical adjustment with maximal reduced reversal backlash
- 0.002mm diametrical adjustment by nonius

Bestell-Nr. / Order number	Wendeplattenhalter
590.070.030.075	314.030.067.006 314.030.067.009

- Wendeplattenhalter müssen separat bestellt werden

- insert holder must be ordered separately

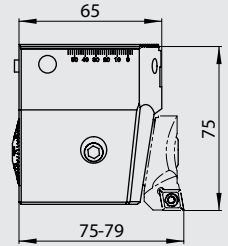

- für die Verwendung auf Verlängerungskonsolen der Serien 560 und 564
- Einstellgenauigkeit 0.001mm im Durchmesser
- direktes Wegmeßsystem (kein Umkehrspiel)
- keine Batterie und Auswerteelektronik im Werkzeug verbaut
- sehr einfache Bedienung
- digital und analog einsetzbar

- for use on extension bridges from series 560 and 564
- 0.001 accuracy in diameter
- direct measurement system (no backlash)
- no battery and electronic evaluation unit inside the tool
- very easy operation
- for digital and analog use

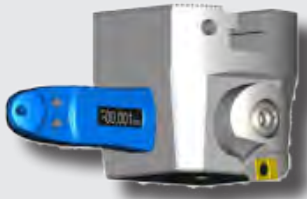

Bestell-Nr. / Order number	Wendeplattenhalter
591.070.030.075	314.030.067.006 314.030.067.009

- Wendeplattenhalter müssen separat bestellt werden
- Anzeigeeinheit muss separat bestellt werden siehe Seite 6 (309.028.024.077).

- insert holder must be ordered separately
- Display unit must be ordered separately see page 6 (309.028.024.077).

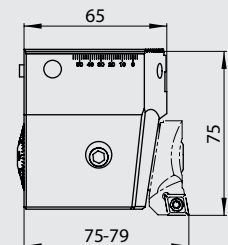

- zur Verwendung mit Feinbohrkopf der Serie 590/591

- for use with fine boring head from serie 590/591

Bestell-Nr. / Order number
594.070.065.072

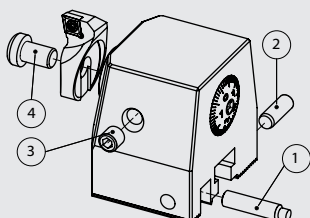
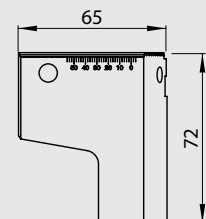

Ersatzteile / Zubehör

Spare parts / Accessories

590/591/594

Für Feinbohrkopf For fine boring head	Bestell-Nr. / Order number	①	Bestell-Nr. / Order number	②	Bestell-Nr. / Order number	③	Bestell-Nr. / Order number	④
	Einstellschraube / Adjustment screw		Stift / Pin		Klemmschraube / Clamping screw		Befestigungsschraube / Fastening screw	
590/591.070.030.075	900.570.008.035		900.570.008.024		900.590.010.020		900.314.010.016	
594.070.065.072	900.570.008.035		900.570.008.024					

Verlängerungskonsolen
ø650-2205

Extension bridges
ø650-2205

562/564

- für die Verwendung auf Aufnahme-
dorn ø60 / ø129 DIN 6357
- Basis aus Aluminium
- fragen Sie uns an für optimierte Kom-
plettlösungen

- for use on holding arbor ø60 / ø129
- basis made of aluminium
- please get in touch with us for
customized solutions

Basis / Basis Bestell-Nr. / Order number	Schieber / Slider Bestell-Nr. / Order number	D	L	Ausdrehdurchmesser / Boring diameter
562.060.063.080	564.000.310.048	630	128	650 – 1105
562.060.108.080	564.000.360.048	1080	128	1100 - 1655
562.060.163.080	564.000.360.048	1630	128	1650 – 2205

- Schieber müssen separat bestellt wer-
den und werden paarweise geliefert
- Ersatzteile siehe Seite 49

- sliders must be ordered separately
and will be supplied in pairs
- spare parts see page 49

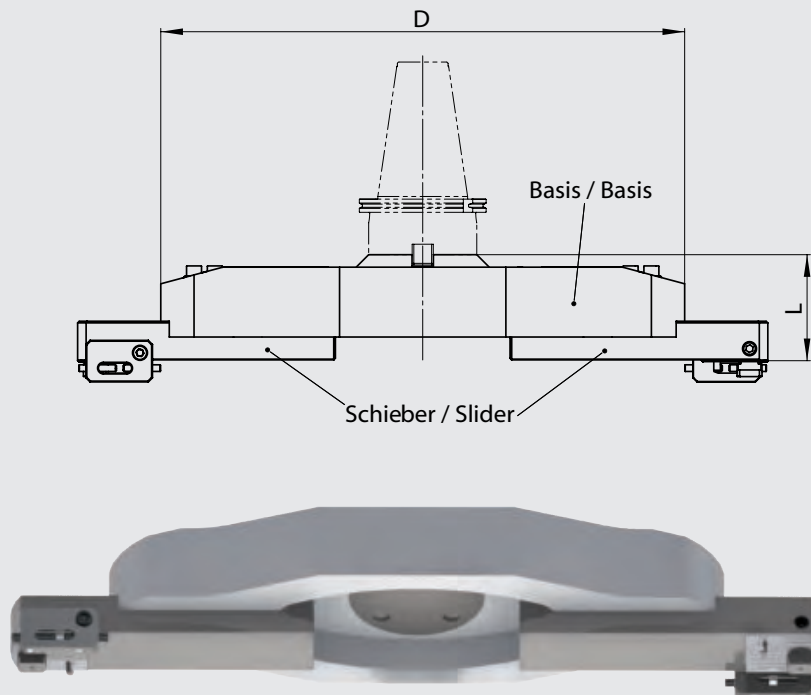

Aufnahmedorn für
Verlängerungskonsolen

Holding arbor for
extension bridges

558

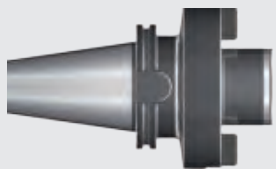

Bestell-Nr. / Order number	SK	d	A	L1	D
558.450.060.070	SK 50	60	70	40	128

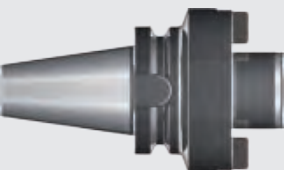

Bestell-Nr. / Order number	BT	d	A	L1	D
558.550.060.080	BT 50	60	80	40	128



Bestell-Nr. / Order number	HSK-A	d	A	L1	D
558.810.060.070	HSK-A 100	60	70	40	128

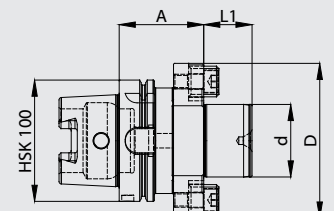
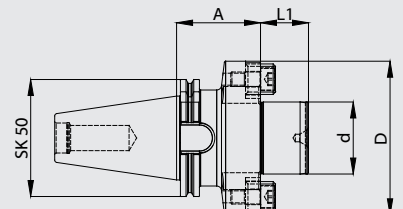



Bestell-Nr. / Order number	ST	D	D1	D2	L1	L
704.064.006.045	ST6+	64	6	25	30	45
704.064.008.045	ST6+	64	8	28	30	45
704.064.010.045	ST6+	64	10	35	30	45
704.064.012.050	ST6+	64	12	42	35	50
704.064.014.050	ST6+	64	14	44	35	50
704.064.016.050	ST6+	64	16	48	35	50
704.064.018.050	ST6+	64	18	50	35	50
704.064.020.055	ST6+	64	20	52	40	55
704.064.025.065	ST6+	64	25	64	50	65

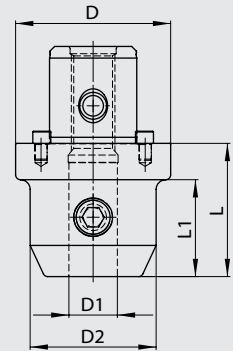

Bestell-Nr. / Order number	ST	D	L	Spannzange / Collet	Spannbereich / Clamping range	D1
724.025.016.035	ST2	25	35	ER 16	0.5-10	22
724.064.025.047	ST6+	64	47	ER 25	1 -16	42
724.064.032.053	ST6+	64	53	ER 32	1 -20	50
724.064.040.065	ST6+	64	65	ER 40	1 -26	63

- Spannmuttern sind im Lieferumfang enthalten
- Schlüssel und Spannzangen müssen separat bestellt werden (siehe Preisliste)

- collet chucks will be supplied with clamping nuts
- keys and collets must be ordered separately (see price list)

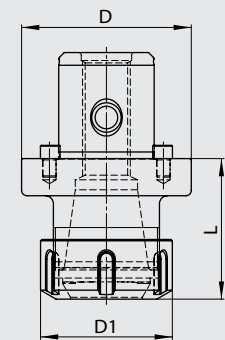

Ersatzteile / Zubehör

Spare parts / Accessories

704/724

Für Fräse n spann- futter	Bestell-Nr. / Order number	Für Spannzan- genfutter	Bestell-Nr. / Order number	Bestell-Nr. / Order number
For end mill adapter	Spannschraube / Clamping screw	For collet chuck adapter	Spannmutter / Clamping nut	Schlüssel / Key
704.064.006.045	900.704.006.010	724.025.016.035	900.724.016.001	900.724.016.010
704.064.008.045	900.704.008.010	724.064.025.047	900.724.025.001	900.724.025.010
704.064.010.045	900.704.010.012	724.064.032.053	900.724.032.001	900.724.032.010
704.064.012.050	900.704.012.016	724.064.040.065	900.724.040.001	900.724.040.010
704.064.014.050	900.704.012.016			
704.064.016.050	900.704.014.016			
704.064.018.050	900.704.014.016			
704.064.020.055	900.704.016.016			
704.064.025.065	900.704.018.020			

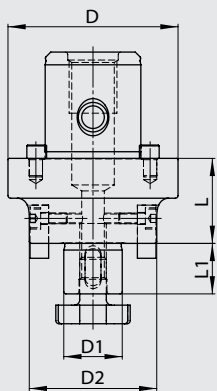

Bestell-Nr. / Order number	ST	D	D1	D2	L1	L
734.064.016.032	ST6+	64	16	39	17	32
734.064.022.032	ST6+	64	22	49	19	32
734.064.027.034	ST6+	64	27	58	21	34
734.064.032.038	ST6+	64	32	70	24	38
734.064.040.040	ST6+	64	40	80	27	40

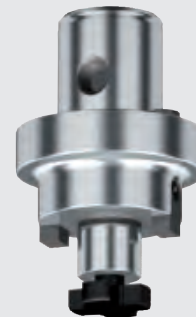

NC-Bohrfutter

NC-Drillchucks

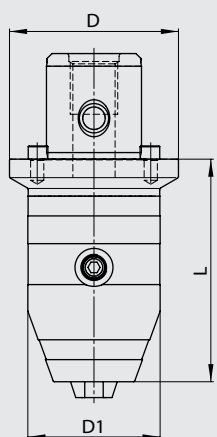

• mit Innenkühlung

• with inner coolant supply

Bestell-Nr. / Order number	ST	D	D1	L	Spannbereich / Clamping range
744.064.013.084	ST6+	64	44	84	1 - 13
744.064.016.084	ST6+	64	49	88	2.5 - 16

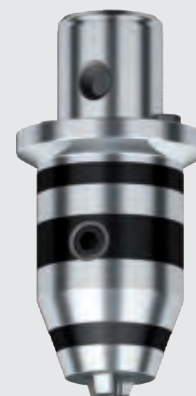

Rohlinge

Blank adapters

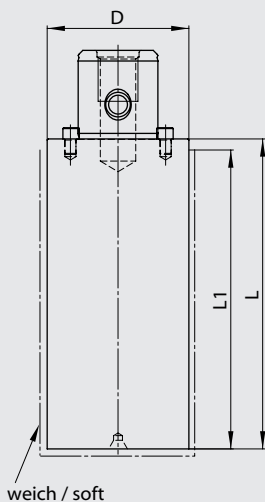

Bestell-Nr. / Order number	ST	D	L	L1
764.020.020.040	ST1	20	40	37
764.025.025.050	ST2	25	50	47
764.032.032.065	ST3	32	65	61
764.039.039.090	ST4	39	90	86
764.050.050.115	ST5	50	115	110
764.064.064.140	ST6+	64	140	135

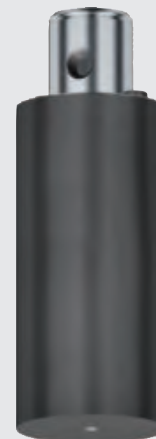





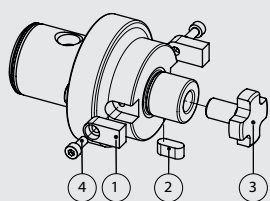









































Ersatzteile / Zubehör

Spare parts / Accessories



Für Aufsteckfräs- dorn	Bestell-Nr. / Order number	Bestell-Nr. / Order number	Bestell-Nr. / Order number	Bestell-Nr. / Order number
For milling arbor	Mitnehmerkeil / Drive lug ①	Passfeder / Splined key ②	Fräseranzugsschraube / Clamping screw ③	Schraube / Screw ④
734.064.016.020	900.734.008.019	900.735.004.012	900.736.008.012	900.737.003.008
734.064.022.020	900.734.010.020	900.735.006.014	900.736.010.016	900.737.004.010
734.064.027.020	900.734.012.023	900.735.007.016	900.736.012.018	900.737.004.010
734.064.032.028	900.734.014.027	900.735.008.018	900.736.016.022	900.737.006.016
734.064.040.028	900.734.016.030	900.735.010.020	900.736.020.030	900.737.006.018

Bestell-Nummer	Wendepplatte	Schneidstoff	Technische Informationen	Materialien	v [m/min]	f [mm/Z]
Order number	Insert	Cutting mat.	Technical information	Materials	v [m/min]	f [mm/r]
800.600.050.022	WCMT 020102	CTU 	Cermet-Wendepplatte (Titan-Carbid / Titan-Nitrid) für Feinbohrarbeiten mit hoher Schnittgeschwindigkeit und gleichmässigem Aufmass.	Stahl Grauguss Aluminium	50–300 50–300 bis 800	0.04 bis 0.10
			Titanium carbide / titanium nitride (Cermet) for fine bore machining with high cutting speed and regular cutting depth.	Steel Cast Iron Aluminium	50–300 50–300 to 800	0.04 to 0.10
800.600.060.022	WCGT 020102	 HUP 	Unbeschichtete Hartmetall-Wendepplatte , allseitig geschliffen mit grossem Spanwinkel für Feinbohrarbeiten. Die Wendepplatte eignet sich insbesondere bei kleinem Aufmass und langen Bohrungen.	Stahl Stahl rostfrei Grauguss Aluminium	50–250 30–200 50–300 bis 800	0.04 bis 0.10
			Uncoated Carbide insert, ground all around with large rake angle for fine bore cutting. The insert is particularly good for small cutting depth in deep bores.	Steel Stainless steel Cast iron Aluminium	50–250 30–200 50–300 to 800	0.04 to 0.10
800.600.070.022	WCGT 020102	 SFH 	Mehrfach beschichtete superfeinstkorn Hartmetall-Wendepplatte zur Bearbeitung von harten und gehärteten Werkstoffen bis 62 HRc . Die Wendepplatte eignet sich hervorragend für Feinbohrarbeiten in gehärtetem Stahl als Alternative zum K-Schleifen.	Stahl weich Stahl HRc 45 Stahl HRc 50 Stahl HRc 55 Stahl HRc 60 Stahl HRc 62	bis 300 80–250 80–200 50–150 30–100 20– 60	0.04 bis 0.20
800.600.070.024	WCGT 020104					
			Repeat coated extremely fine grain carbide insert for machining of hard and hardened steels up to 62 HRc . Very suitable for fine boring of precision bores in hardened steel as an alternative to Jig-grinding.	Steel soft Steel HRc 45 Steel HRc 50 Steel HRc 55 Steel HRc 60 Steel HRc 62	bis 300 80–250 80–200 50–150 30–100 20– 60	0.04 to 0.20
800.600.200.062	CCMT 060202	 CTU 	Cermet-Wendepplatte (Titan-Carbid / Titan-Nitrid) für niedrige bis hohe Schnittgeschwindigkeiten beim Schlichten mit gleichbleibendem Aufmass. Auch für leichte Schrupparbeiten einsetzbar. Bester Widerstand gegen Verschleiss und Schneidekantendeformation. Geeignet für Feinbohrarbeiten mit normalem Aufmass von 0.25 mm im Durchmesser.	Stahl Stahl rostfrei Grauguss Aluminium Buntmetall	50–300 30–250 50–300 bis 800 bis 500	0.08 bis 0.15
800.600.200.064	CCMT 060204					
800.600.200.092	CCMT 09T302					
800.600.200.094	CCMT 09T304					
800.600.200.098	CCMT 09T308					
800.600.200.128	CCMT 120408					
			Titanium carbide / titanium nitride (Cermet) for finishing with low to high cutting speeds with regular cutting depth. Also for light roughing. High resistance to wear and tip deformation. Suitable for fine boring with normal cutting depths from 0.25 mm in bored diameter.	Steel Stainless steel Cast iron Aluminium Copper alloys	50–300 30–250 50–300 to 800 to 500	0.08 to 0.15
800.600.850.062	CCGT 060202L	 ICH 	Hochwiderstandsfähig gegen Brüche durch die besondere Zusammensetzung des Basismaterial plus der speziellen TiCN-Beschichtung. Sehr hohe mechanische Stabilität und Verschleissbeständigkeit. Sehr gut geeignet für unterbrochenen Schnitt.	Stahl weich Stahl HRc 45 Stahl HRc 50 Stahl HRc 55 Stahl rostfrei Grauguss	bis 300 80–250 80–200 50–150 30–200 50–300	0.04 to 0.20
800.600.850.064	CCGT 060204L					
800.600.850.094	CCGT 09T304L					
			Excellent toughness and wear resistance due to the special composition of the base material plus the special TiCN coating. Very suitable for interrupted cuts	Steel soft Steel HRc 45 Steel HRc 50 Steel HRc 55 Stainless steel Cast iron	bis 300 80–250 80–200 50–150 30–200 50–300	0.04 to 0.20

Bestell-Nummer	Wendeplatte	Schneidstoff	Technische Informationen	Materialen	v [m/min]	f [mm/Z]
Order number	Insert	Cutting mat.	Technical information	Materials	v [m/min]	f [mm/r]
800.600.300.062	CCGT 060202L 	CTG 	Allseitig geschliffene, hochpositive Cermet-Wendeplatte (Titan-Carbid / Titan-Nitrid), für alle Feinbohrarbeiten. Die Wendeplatte eignet sich insbesondere bei kleinem Aufmass und langen Bohrungen. Durch den grossen Spanwinkel sind die Druck- und Schnittkräfte sehr gering.	Stahl Stahl rostfrei Grauguss Aluminium Buntmetall	50–300 30–250 50–250 bis 800 bis 500	0.06 bis 0.12
800.600.300.064	CCGT 060204L 					
800.600.300.092	CCGT 09T302L 					
800.600.300.094	CCGT 09T304L 					
		All ground, Cermet insert with highly positive rake angle for all fine bore machining. Very suitable for deep bores with small cutting depth. Low cutting and pressing forces due to large rake angle.		Steel Stainless steel Cast iron Aluminium Copper alloys	50–300 30–250 50–250 to 800 to 500	0.06 to 0.12
		800.600.800.062	CCGT 060202L 	SFH 	Mehrfach beschichtete superfeinstkorn Hartmetall-Wendeplatte zur Bearbeitung von harten und gehärteten Werkstoffen bis 62 HRC . Die Wendeplatte eignet sich hervorragend für Feinbohrarbeiten in gehärtetem Stahl als Alternative zum K-Schleifen.	Stahl weich Stahl HRC 45 Stahl HRC 50 Stahl HRC 55 Stahl HRC 60 Stahl HRC 62
800.600.800.064	CCGT 060204L 					
800.600.800.092	CCGT 09T302L 					
800.600.800.094	CCGT 09T304L 					
		Repeat coated extremely fine grain carbide insert for machining of hard and hardened steels up to 62 HRC . Very suitable for fine boring of precision bores in hardened steel as an alternative to Jig-grinding.		Steel soft Steel HRC 45 Steel HRC 50 Steel HRC 55 Steel HRC 60 Steel HRC 62	bis 300 80–250 80–200 50–150 30–100 20– 60	0.04 to 0.20
		800.600.400.064	CCMT 060204 	HBH  	Mehrfach beschichtete Hartmetall-Wendeplatte mit hoher Verschleissfestigkeit und grossem Widerstand gegen plastische Verformung. Generell geeignet für die Stahlbearbeitung mit mittleren bis hohen Schnittgeschwindigkeiten.	Stahl Stahl rostfrei Grauguss Sphäroguss Aluminium Buntmetall
800.600.400.094	CCMT 09T304 					
800.600.400.098	CCMT 09T308 					
800.600.401.128	CCMT 1204.08 					
800.600.400.128	CNMG 120408 					
800.600.400.168	CNMG 160608 					
800.600.400.169	CNMG 160612 					
800.600.400.198	CNMG 190612 					
800.600.400.199	CNMG 190616 					
		Repeat coated carbide insert with high wear and plastic deformation resistance. Generally used for machining of ferrous steels with middle to high cutting speeds.		Steel Stainless steel Cast iron Spheroidal cast iron Aluminium Copper alloys	20–280 30–250 50–250 50–180 to 800 to 500	0.10 to 0.40
		800.600.500.128	CNMM 120408 	HBZ 	Mehrfach beschichtete Hartmetall-Wendeplatte mit höchster Zähigkeit und Stabilität der Schneidekante. Geeignet für Stahlbearbeitung durch die positive Schneidegeometrie auch bei unterbrochenem Schnitt.	Stahl Stahl rostfrei Grauguss Sphäroguss Aluminium Buntmetall
800.600.500.168	CNMM 160608 					
800.600.500.169	CNMM 160612 					
800.600.500.198	CNMM 190612 					
800.600.500.199	CNMM 190616 					
		Repeat coated carbide insert, very tough with high stability cutting edge. Suitable for machining of ferrous steels also with interrupted cut due to its positive cutting geometry.		Steel Stainless steel Cast iron Spheroidal cast iron Aluminium Copper alloys	50–300 30–250 50–300 50–200 to 800 to 500	0.10 to 0.60



SWISS  TOOLS[®] Swiss Tool Systems AG
Wydenstrasse 28
CH-8575 Bürglen
Phone +41 (0)71 634 85 20
Fax +41 (0)71 634 85 29
www.swisstools.org