

# klamp™

Efficient workholding



Collet Chucks  
Mandrels  
Collets

---



**efficient** | i'fiʃ(ə) nt |

*adjective*

*(of a system or machine) achieving maximum productivity with minimum wasted effort or expense.*

**workholding** | wɜ:k'hōl-dɪŋ |

*noun*

*refers to any device that is used to secure a workpiece against the forces of machining.*

---



## Index of Klamp Products

**Collet Chucks QC & C Series****Page 3**

Quick Change Collet Chucks	QCRL Series	Page 4-7
Short Series Collet Chucks	CRS Series	Page 8-9
Long Series Collet Chucks	CRL Series	Page 10-11

**Spring Collets QC & C Series****Page 13**

D171E Spring Collets	Range – 2mm to 36mm	Page 14
D173E Spring Collets	Range – 2mm to 42mm	Page 15
D185E Spring Collets	Range – 3mm to 60mm	Page 16
D853 Spring Collets	Range – 2mm to 54mm	Page 17
D193E Spring Collets	Range – 12mm to 80mm	Page 18
Accessories	Collet Stops & Ejectors	Page 19

**Varibore Collets QC & C Series****Page 21**

Varibore Collets	Range – 1.58mm to 79.37mm	Page 22
Varibore Collets DIN 6343	Range – 4mm to 80mm	Page 23
Rubber Flex Collets	Range – 7mm to 65mm	Page 24-25

**Collet Chucks D Series****Page 27**

Pull Back Collet Chucks	DHP Series	Page 28-29
Fixed Length Collet Chucks	DKF Series	Page 30-31

**DC Collets D Series****Page 33**

DC42 Collets	Range – 4mm to 42mm	Page 34
DC52 Collets	Range – 4mm to 52mm	Page 35
DC65 Collets	Range – 4mm to 65mm	Page 36
DC80 Collets	Range – 7mm to 80mm	Page 37
DC100 Collets	Range – 16mm to 100mm	Page 38
Accessories	Collet Changing Device, Collet Stops & Ejectors	Page 39

**Collet Chucks Low Profile – Pull Back****Page 41**

5C & 16C Collet Chucks		Page 42-43
5C & 16C Collets	Range – 1mm-42mm	Page 44

**Expanding Mandrels KEM Series****Page 47**

Power actuated Expanding Mandrels for Lathes	KEM Series	Page 48-49
Manual Actuated Expanding Mandrels	KEM-MA Series	Page 50
Sleeve Options – Standard and Flush	Range – 12.4mm-82.7mm	Pages 51-53



# Collet Chucks

## QC & C Series

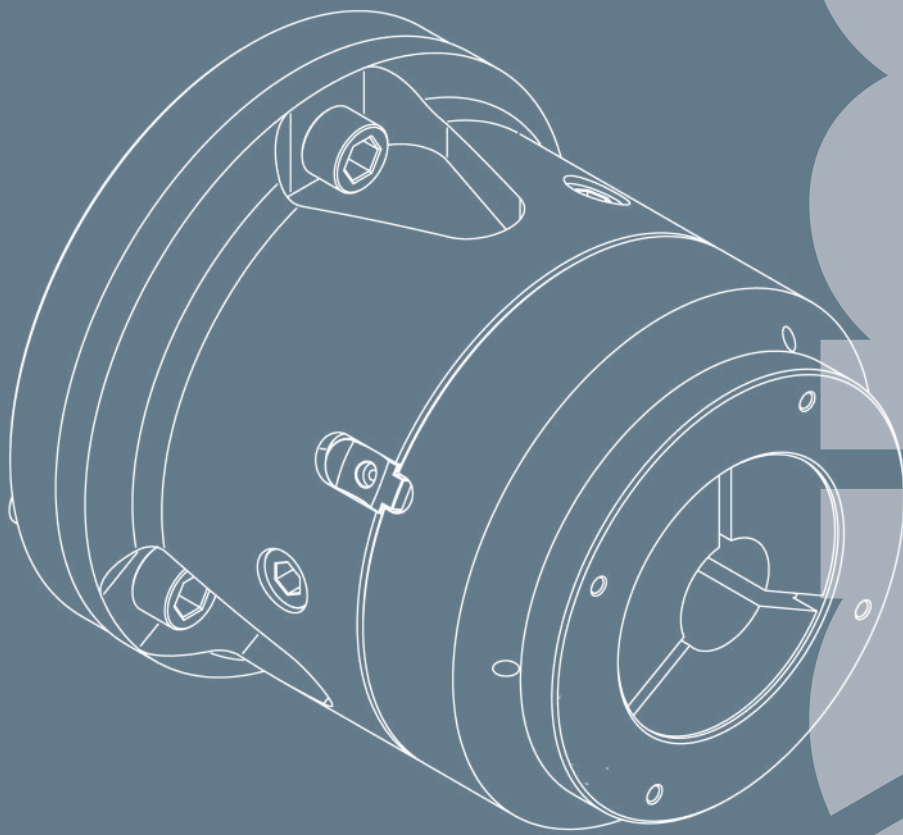

Collet Chuck  
QC & C Series

## Quick Change Series Power Collet Chuck for Bar Machining

### Two Different Systems:

#### Direct Mount System

- This system mounts directly to the lathe spindle to ensure a consistent mounting without the need for correction.
- Klamp QDCRL collet chucks are suitable for spring, varibore and rubberflex collets increasing its flexibility. Varibore and rubberflex collets allow rough, unfinished bar to be machined in the first operation and spring collets can be used for high accuracy in the second operation.
- Workpiece remains in a fixed position during actuation allowing for precise z-axis positioning. A tapered sleeve is pushed forward, compressing the collet and gripping the workpiece.
- All Klamp collet chucks are case hardened, optimising the rigidity, strength and durability.



#### Modular System

- As the direct mount system except with interchangeable adaptors enables the collet chuck to be moved from one machine spindle nose to another
- Cost-effective as only additional adaptors and connectors are required when changing different spindle/machine.
- The need for adjustment is minimal, meaning less machine downtime.



### Ultra-Fast 10 Second Collet Changes

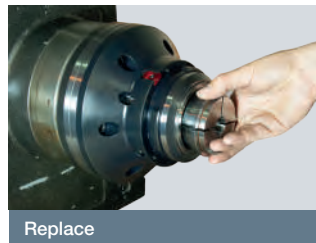

### 3 Different Collet Types Available

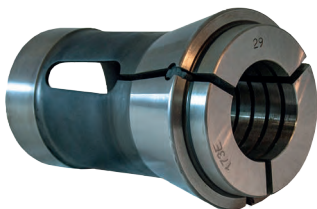

#### Spring Collets\*

Suited for second operation work, collets are size matched according to gripped diameters, enabling you to have a high gripping accuracy. Collets can be supplied as smooth or serrated as required.



#### Varibore Collets\*\*

Ideal for first operation work as they have a 2-3mm gripping range enabling you to handle rough bar. Supplied either as smooth, serrated or super grip.

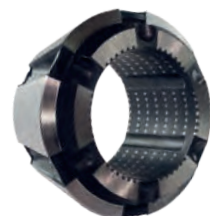

#### Rubberflex Collets\*\*\*

The same accuracy specification as spring collets. Elastic rubber-metal vulcanization allows a clamping range of +/- 1mm to the nominal diameter.



**Quick Change Series Power Collet Chuck for Bar Machining**

**Bar Seals Prevent Swarf & Coolant Ingress**



Remove bar seal from housing



Mark the diameter you require



Cut out the diameter



Reassemble and proceed

**Adjustable Collet Mounted Workstop for Spring Collets**



- Easy to use, installation time – less than one minute
- Available for D173E (Part No: **WS-D173E**) and D185E (Part No: **WS-D185E**) spring collet types
- Suitable for round, square and hexagon spring collets
- No deformation of collet shank
- No influence on clamping characteristics of collet or collet chuck



Insert collet work stopper



Lock stopper housing in position



Adjust stopper shaft position



Lock stopper shaft and install

**Application Advantages**

- Klamp collet chucks are designed to work with bar loaders and bar feeders by not interfering with the actions of the bar feeder or loader.
- All types of QCRL42, QCRL60 & QCRL80 have interchangeable match ground reduction sleeves to allow you to use a wider range of collets on one chuck.
- Wide adaptor plates for all models available upon request.
- Clamping/unclamping of chuck during spindle rotation is possible.
- Less deformation of thin-walled components during clamping.
- High operating reliability due to a minimum number of parts.
- High axial positioning accuracy of the components by means of push type collet system.

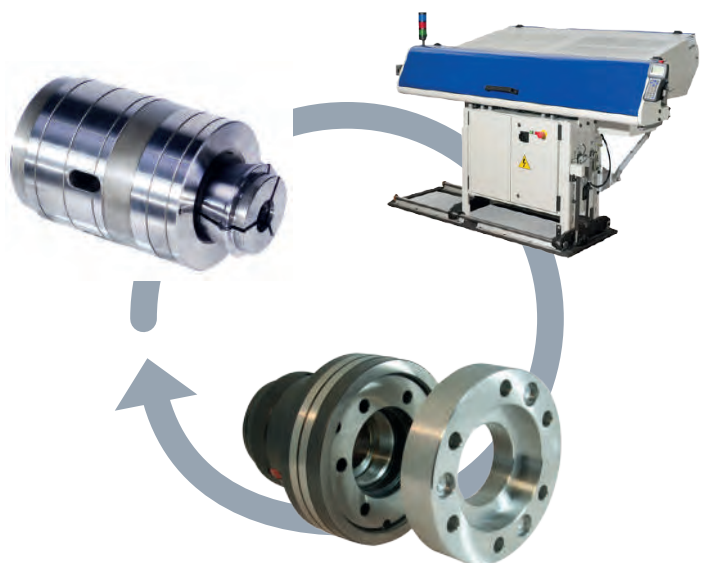

\* See pages 14-18 for more Spring Collet information.

\*\* See pages 22-23 for more Varibore Collet information.

\*\*\* DRFC673 Rubber-flex collets are only suitable for the CRL42 Collet chuck and are available in smooth and full grip versions (smooth version is only available for 11mm diameters and smaller). DRFC677 Rubber-flex collets are only suitable for the CRL60 Collet chuck and are available in smooth and full grip versions (smooth version is only available for 61mm diameters and larger). See pages 24-25 for more information.

## Quick Change Series Power Collet Chuck for Bar Machining

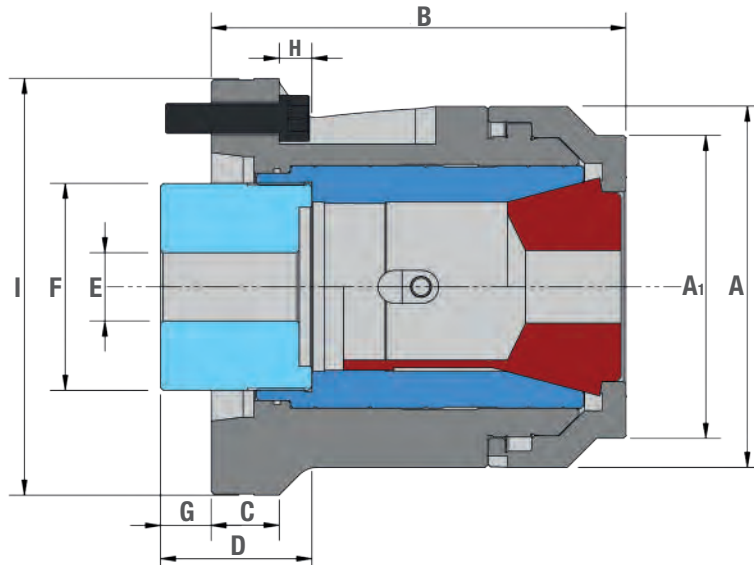

KLAMP Type	QDCRL42 DIN	QDCRL60 DIN	QCRS66 Inch		QCRS80 Inch		QCRL80 DIN		
Mounting	A5	A6	Z220	A8	Z220	A8	Z220	A8	
Part Number	QDCRL42A5	QDCRL60A6	QCRS66	QCRS66A8	QCRS80	QCRS80A8	QCRL80	QCRL80A8	
Spring Collet Type	D-173E	D-185E	-	-	-	-	D-193E		
Spring Collet Gripping Range	Minimum	2	3	-	-	-	12		
	Maximum	42	60	-	-	-	80		
Spring Collet Increments	0.5	0.5	-	-	-	-	0.5		
Varibore Collet Type	D-673	D-677	D-285		D-175		D-660		
Varibore Collet Gripping Range	Minimum	4	4	3	12		12		
	Maximum	42	60	66	80		80		
Varibore Collet Increments	2	2	3	3	3		3		
Rubberflex Collet Type	DRFC-673	DRFC-677	-	-	-	-	-		
Rubberflex Collet Gripping Range	Minimum	7*	19*	-	-	-	-		
	Maximum	45*	65*	-	-	-	-		
Rubberflex Collet Increments	2	2	-	-	-	-	-		
A	113	143	162		196		196		
A1	93	120	136		166		166		
B	136	164.5	146		164.5	162	216	209	
C	N / A	N / A	N / A		N / A		N / A		
D	60	60	80		80		80		
E Maximum	M58 x 2.0	M75 x 2.0	M90 x 2.0		M90 x 2.0		M90 x 2.0		
F	65	82	100		100		100		
G Maximum	23	20	5	25	37	20	33	16	
G Minimum	16	13	-5	15	25	8	25	8	
H	N / A	N / A	N / A		N / A		N / A		
I	135		230	220	230	220	230	220	
Sleeve stroke	7	7	10		12		8		
Max. input force	kN	25	30	38	45		45		
Max. Gripping Force	kN	55	60	84	78		78		
Max. Speed	min-1	7100	6300	4500	4500		4500		
Net Weight	kg	10	17	23.3	21.5	28.3	28.5	37	36
Matching Kitagawa Cylinders	S1246 SS1246	S1552 S1875	S1552 S1875		S2091 SS1881		S2091 SS1881		

## Quick Change Series Power Collet Chuck for Bar Machining

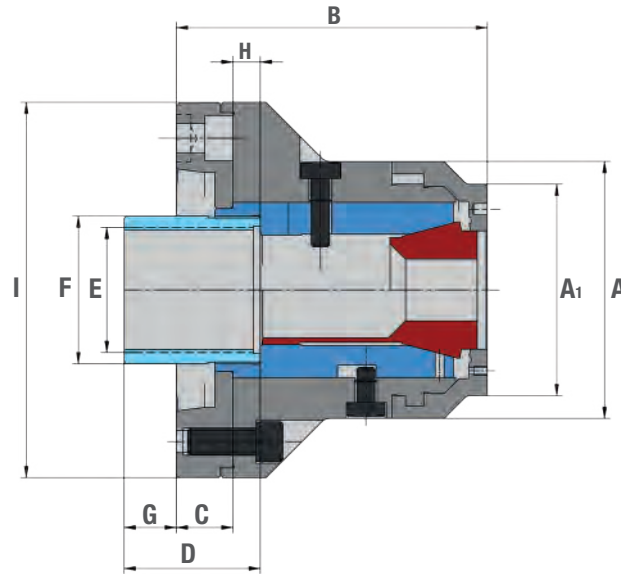

KLAMP Type	Q-CRL42 DIN			Q-CRL54 Inch				Q-CRL60 DIN				
	Z140	A5	A6	Z170	A5	A6	A8	Z170	A5	A6	A8	
Part Number	QCRL42	QCRL42A5	QCRL42A6	QCRL54	QCRL54A5	QCRL54A6	QCRL54A8	QCRL60	QCRL60A5	QCRL60A6	QCRL60A8	
Spring Collet Type	D173E			D853				D185E				
Spring Collet Gripping Range	Minimum	2			1.6				3			
	Maximum	42			54				60			
Spring collet increments	0.5			0.5				0.5				
Varibore Collet Type	D673			D-120				D-677				
Varibore Collet Gripping Range	Minimum	4			3				4			
	Maximum	42			53.9				60			
Varibore Collet Increments	2			3				2				
Rubberflex Collet Type	DRFC673			-				DRFC677				
Rubberflex Collet Gripping Range	Minimum	7			-				19*			
	Maximum	45			-				65*			
Rubberflex Collet Increments	2			-				2				
A	113			143				143				
A1	93			118				118				
B	137			175	184	169	169	171	180	165	165	
C	25			31.5	46.5	31.5	31.5	31.5	46.5	31.5	31.5	
D	60			60				60				
E Maximum	M58 x 1.5			M75 x 1.5				M75 x 1.5				
F	65			82				82				
G Maximum	17	23	23	15	25	21	21	14	-22	21	21	
G Minimum	10	16	16	5	15	11	11	7	-15	14	14	
H	12			8.3				8.3				
I	165			220				220				
Sleeve stroke	7			10				7				
Max. input force	kN	25			30				30			
Max. Gripping Force	kN	55			60				60			
Max. Speed	min <sup>-1</sup>	7100			6300				6300			
Net Weight	kg	14.5	14	13.5	28.3	32	28.3	26.3	28.3	32	28.3	26.3
Matching Kitagawa Cylinders	S1246 SS1246			S1552 S1875				S1552 S1875				

**Short Series Power Collet Chuck for Bar Machining**

**Short Body/Wide Range**

Varibore & rubber-flex collets allow for a compact body design maximising the lathe work envelope. Gripping capacities of the series range from 3 mm to 66mm

**High Speed**

Direct mount design ensures high concentricity suitable for higher speed operations.

**First Operation Collet Chuck**

Klamp CRS collet chucks are suitable for collets which have a large gripping range. Allowing the collet chuck to handle very rough and unfinished bar, preparing it for a high accuracy second operation.

**Fixed Length Collet**

Workpiece remains in a fixed position during actuation, allowing for precise z-axis positioning. A tapered sleeve is pushed forward, compressing the collet and gripping the workpiece.

**Problem Free Installation**

Klamp collet chucks are provided with mounting bolts and an optional custom-machined drawtube connector, allowing you to start using the Klamp collet chuck straight out of the box.

**Quick & Easy Mounting**

Klamp collet chucks mount directly to the lathe spindle or use a precision adaptor plate to ensure a consistent mounting without the need for correction. The precision fit of the Klamp collet chuck enhances the rigidity of the overall system. The need for adjustment is minimal, meaning less machine downtime.

**Long service life**

All Klamp collet chucks are case hardened, optimising the rigidity, strength and durability.



**Designed for Bar Pushers/ Barfeeders**



Fixed-length Klamp collet chucks are designed to work with bar loaders and bar feeders by not interfering with the process of the bar feeder action.

**2 Different Collet Types Available**



**Varibore Collets\*\***

Ideal for first operation work as they have a 2-3mm gripping range enabling you to handle rough bar. Supplied either as smooth, serrated or super grip.

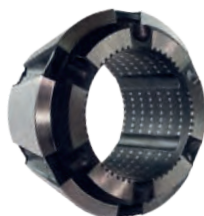

**Rubberflex Collets\*\*\***

The same accuracy specification as spring collets. Elastic rubber-metal vulcanization allows a clamping range of +/- 1mm to the nominal diameter.

## Short Series Power Collet Chuck for Bar Machining

Dia. 1

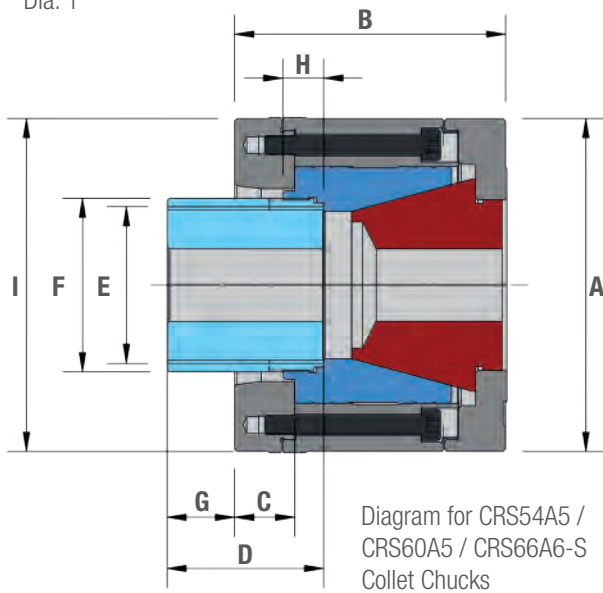

Dia. 2

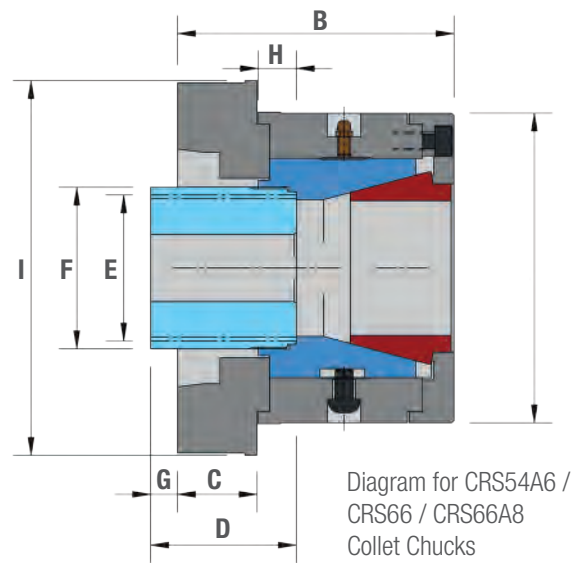

KLAMP Type		CRS54		CRS60	CRS66		
Mounting		A5	A6	A5	Z220	A6	A8
Part number		CRS54A5	CRS54A6	CRS60A5	CRS66	CRS66A6-S	CRS66A8
Varibore Collet Type		D-120		D-677	D-285		
Varibore Collet Gripping range*	Minimum	3		4	3.2		
	Maximum	53.9		60	66.6		
Varibore Collet Increments		3		2	3		
Rubberflex Collet Type		-		DRFC677	-		
Rubberflex Collet Gripping Range**	Minimum	-		19*	-		
	Maximum	-		65*	-		
Rubberflex Collet Increments		-		2	-		
A		138		138	150	165	150
B		113	127.4	107.5	134	131	140
C		25	41	25	24	N/A	30
D		65		65	80		
E Maximum		M65 x 1.5		M65 x 1.5	M80 x 2.0		
F		72		72	90		
G Maximum		28	12	28	27	29.5	21
G Minimum		18	2	21	17	19.5	11
H		17		17	24		
I		N/A	167	N/A	230	N/A	210
Sleeve stroke		10		7	10		
Max. input force	kN	30		30	38		
Max. Gripping Force	kN	60		60	84		
Max. Speed	min <sup>-1</sup>	6300		6300	4500		
Net Weight	kg	11	12.5	11	19		18
Matching Kitagawa Cylinders		S1552		S1552	S1875		

\* See pages 22-23 for more Varibore Collet information

\*\* DRFC677 Rubber-flex collets are only suitable for the CRS60 Collet chuck and are available in smooth and full grip versions (smooth version is only available for 61 mm diameters and larger).

## Long Series Power Collet Chuck for Bar Machining

### Long Body/Wide Range

High accuracy spring collets require a longer body design but Klamp collet chuck design ensures that all external dimensions have been optimised to provide maximum tool clearance. Gripping capacities of the series range from 1.6mm to 80mm

### High Speed

Direct mount design ensures high concentricity suitable for higher speed operations.

### First & Second Operation Collet Chuck

Klamp CRL collet chucks are suitable for spring, varibore and rubberflex collets increasing its flexibility. Varibore and rubberflex collets allow rough, unfinished bar to be machined in the first operation and spring collets can be used for high accuracy in the second operation.

### Fixed Length Collet

Workpiece remains in a fixed position during actuation allowing for precise z-axis positioning. A tapered sleeve is pushed forward, compressing the collet and gripping the workpiece.

### Problem Free Installation

Klamp collet chucks are provided with mounting bolts and an optional custom machined drawtube connector allowing you to start using the Klamp collet chuck straight out of the box.

### Adjustable Collets Mounted Workstop for Spring Collets



- Easy to use, installation time – less than one minute
- Available for D173E (Part No: **WS-D173E**) and D185E (Part No: **WS-D185E**) spring collet types
- Suitable for round, square and hexagon spring collets
- No deformation of collet shank
- No influence on clamping characteristics of collet or collet chuck

### 3 Different Collet Types Available

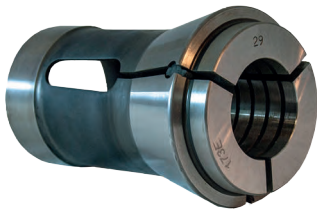

#### Spring Collets\*

Suited for second operation work, collets are size matched according to gripped diameters, enabling you to have a high gripping accuracy. Collets can be supplied as smooth or serrated as required.



#### Varibore Collets\*\*

Ideal for first operation work as they have a 2-3mm gripping range enabling you to handle rough bar. Supplied either as smooth, serrated or super grip.

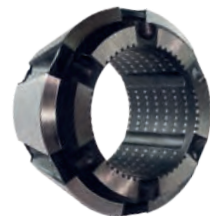

#### Rubberflex Collets\*\*\*

The same accuracy specification as spring collets. Elastic rubber-metal vulcanization allows a clamping range of +/- 1mm to the nominal diameter.



### Quick & Easy Mounting

Klamp collet chucks mount directly to the lathe spindle or use a precision adaptor plate to ensure a consistent mounting without the need for correction. The precision fit of the Klamp collet chuck enhances the rigidity of the overall system. The need for adjustment is minimal, meaning less machine downtime.

### Long service life

All Klamp collet chucks are case hardened, optimising the rigidity, strength and durability.

### Designed for Bar Pushers/Barfeeders

Fixed-length Klamp collet chucks are designed to work with bar loaders and bar feeders by not interfering with the process of the bar feeder action.



## Long Series Power Collet Chuck for Bar Machining

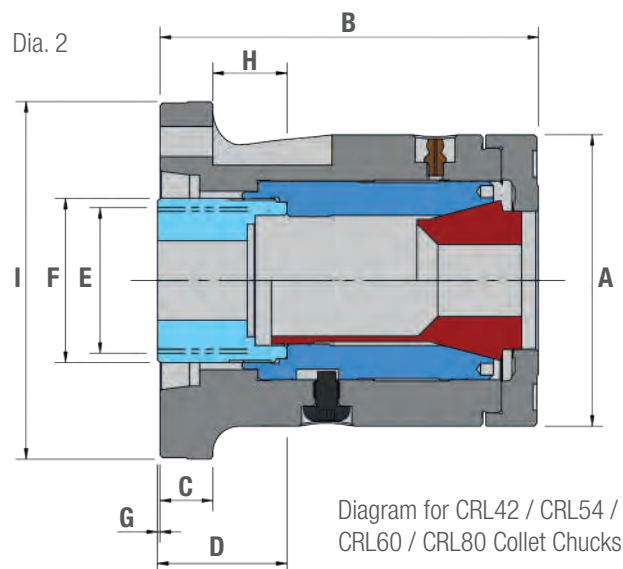
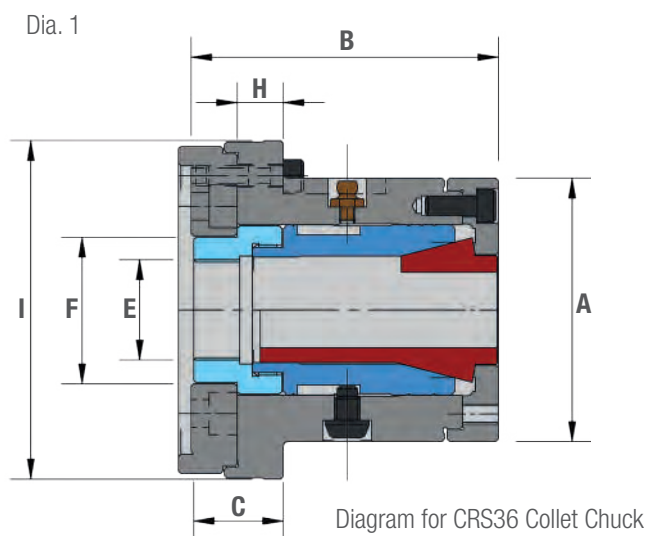

KLAMP Type		CRS36	CRL42		CRL54	CRL60			CRL80		
Mounting		Z115	Z140	A5	A6	A6	Z170	A6	A8	Z220	A8
Part Number		CRS36	CRL42	CRL42A5	CRL42A6	CRL54A6	CRL60	CRL60A6	CRL60A8	CRL80	CRL80A8
Spring Collet Type		D171E	D173E		D853	D185E			D193E		
Spring Collet Gripping Range *	Minimum	1.6	2		2	3			12		
	Maximum	36	42		54	60			80		
Spring Collet Increments		0.5	0.5		0.5	0.5			0.5		
Varibore Collet Type		D671	D673		D120	D677			D660		
Varibore Collet Gripping range**	Minimum	4	4		4	4			12		
	Maximum	36	42		53.9	60			80		
Varibore Collet Increments		2	2		3	2			3		
Rubberflex Collet Type		-	DRFC673		-	DRFC677			-		
Rubberflex Collet Gripping Range***	Minimum	-	7*		-	19*			-		
	Maximum	-	43*		-	65*			-		
Rubberflex Collet Increments		-	2		-	2			-		
A		105	110		138	138			190		
B		125	128	143	145	166	143	160	156	170	176
C		18	20	20	30	27	24	27	36	19	25
D		35	49		48	48			63		
E Maximum		M50 x 1.5	M55 x 1.5		M70 x 1.5	M70 x 1.5			M90 x 2.0		
F		58	62		80	80			100		
G Maximum		-1	16	1	-1	-2	15	-2	2	48	42
		-8	9	-6	-8	-12	8	-9	-5	36	30
G Minimum		-8	9	-6	-8	-12	8	-9	-5	36	30
		-8	9	-6	-8	-12	8	-9	-5	36	30
H		18	18	28	19	23	14	23	9	13	13
I		135	160	135	165	165	190	165	210	230	220
Sleeve stroke		7	7		10	7			12		
Max. input force	kN	18	25		30	30			45		
Max. Gripping Force	kN	36	55		60	60			78		
Max. Speed	min <sup>-1</sup>	7000	7100		6300	6300			4500		
Net Weight	kg	8	9	9.5	11	16	15.2	16	19	30	30
Matching Kitagawa Cylinders		S1036	S1246		S1552	S1552/S1875			S2091		

\* See pages 14-18 for more Spring Collet information.

\*\* See pages 22-23 for more Varibore Collet information.

\*\*\* DRFC673 Rubber-flex collets are only suitable for the CRL42 Collet chuck and are available in smooth and full grip versions (smooth version is only available for 11mm diameters and smaller). DRFC677 Rubber-flex collets are only suitable for the CRL60 Collet chuck and are available in smooth and full grip versions (smooth version is only available for 61mm diameters and larger). See pages 24-25 for more information.





# Spring Collets

to suit **QC & C Series**



Spring Collets  
QC & C Series

## Spring Collets for CRS36 Collet Chucks

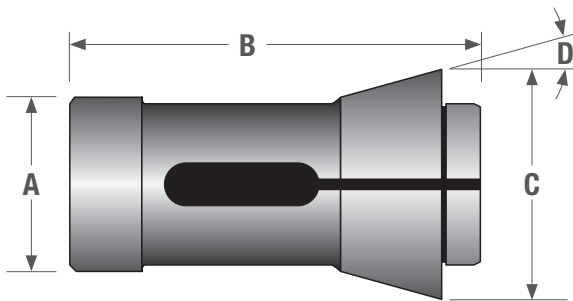
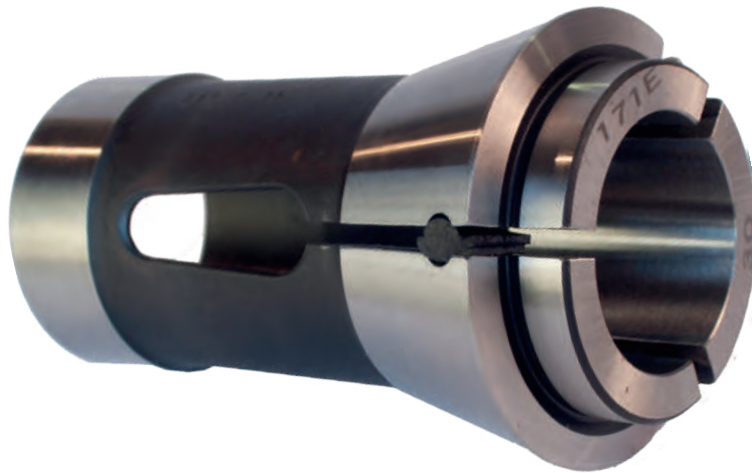

### D171E Spring Collets

- DIN 6343 Type: 8742
- Round standard shape only
- Specify which gripping surface you require Annular serrations or smooth
- 0.5mm sizes and other shapes available upon request

### Dimensions (Metric)

A	B	C	D
42	94	55	15°

Gripping Diameter	Round
2mm	D171E R02
3mm	D171E R03
4mm	D171E R04
5mm	D171E R05
6mm	D171E R06
7mm	D171E R07
8mm	D171E R08
9mm	D171E R09
10mm	D171E R10
11mm	D171E R11
12mm	D171E R12
13mm	D171E R13
14mm	D171E R14
15mm	D171E R15
16mm	D171E R16
17mm	D171E R17
18mm	D171E R18
19mm	D171E R19

Gripping Diameter	Round
20mm	D171E R20
21mm	D171E R21
22mm	D171E R22
23mm	D171E R23
24mm	D171E R24
25mm	D171E R25
26mm	D171E R26
27mm	D171E R27
28mm	D171E R28
29mm	D171E R29
30mm	D171E R30
31mm	D171E R31
32mm	D171E R32
33mm	D171E R33
34mm	D171E R34
35mm	D171E R35
36mm	D171E R36

Emergency Collet with soft face and pilot hole 3mm diameter is available – Part No. **D171E-EMERGENCY**

## Spring Collets for CRL42 and QCRL42 Collet Chucks

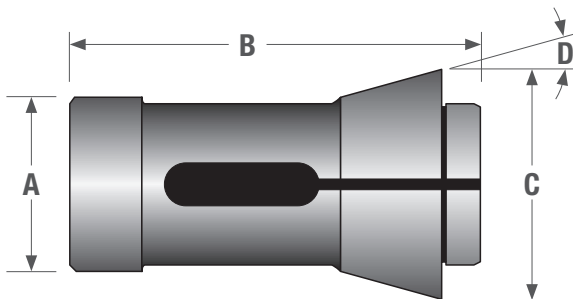
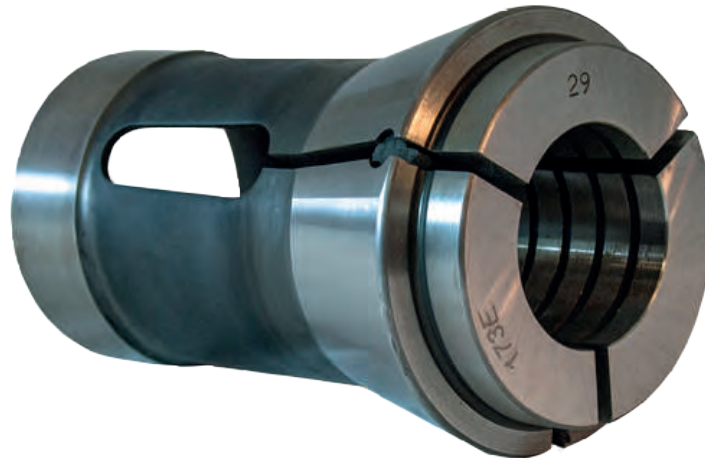

### D173E Spring Collets

- DIN 6343 Type: 4728 (Also known as B42)
- Round, Hexagon or Square
- Specify which gripping surface you require Annular serrations or smooth
- 0.5mm sizes and other shapes available upon request

### Dimensions (Metric)

A	B	C	D
48	94	60	15°

Gripping Diameter	Round	Hexagon	Square
2mm	D173E R02	-	-
3mm	D173E R03	-	-
4mm	D173E R04	-	-
5mm	D173E R05	D173E X05	D173E S05
6mm	D173E R06	-	D173E S06
7mm	D173E R07	D173E X07	D173E S07
8mm	D173E R08	D173E X08	D173E S08
9mm	D173E R09	-	-
10mm	D173E R10	D173E X10	D173E S10
11mm	D173E R11	D173E X11	-
12mm	D173E R12	D173E X12	D173E S12
13mm	D173E R13	D173E X13	-
14mm	D173E R14	D173E X14	D173E S14
15mm	D173E R15	D173E X15	D173E S15
16mm	D173E R16	D173E X16	D173E S16
17mm	D173E R17	D173E X17	-
18mm	D173E R18	D173E X18	D173E S18
19mm	D173E R19	D173E X19	-
20mm	D173E R20	D173E X20	D173E S20
21mm	D173E R21	-	-
22mm	D173E R22	D173E X22	D173E S22

Gripping Diameter	Round	Hexagon	Square
23mm	D173E R23	-	-
24mm	D173E R24	D173E X24	-
25mm	D173E R25	D173E X25	D173E S25
26mm	D173E R26	D173E X26	-
27mm	D173E R27	D173E X27	-
28mm	D173E R28	-	D173E S28
29mm	D173E R29	-	-
30mm	D173E R30	D173E X30	-
31mm	D173E R31	-	-
32mm	D173E R32	D173E X32	-
33mm	D173E R33	-	-
34mm	D173E R34	-	-
35mm	D173E R35	D173E X35	-
36mm	D173E R36	D173E X36	-
37mm	D173E R37	-	-
38mm	D173E R38	-	-
39mm	D173E R39	-	-
40mm	D173E R40	-	-
41mm	D173E R41	-	-
42mm	D173E R42	-	-

Emergency Collet with soft face and pilot hole 3mm diameter is available – Part No. **D173E-EMERGENCY**

## Spring collets for CRL60 and QCRL60 Collet Chucks

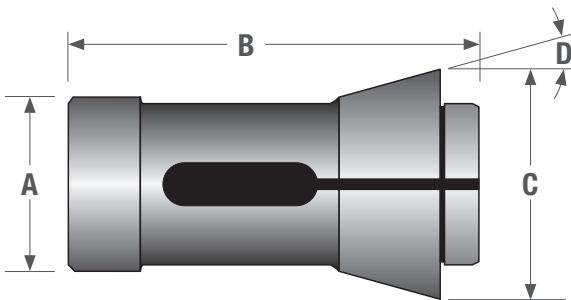

### D185E Spring Collets

- DIN 6343 Type: 4291 (Also known as B60)
- Round, Hexagon or Square
- Specify which gripping surface you require Annular serrations or smooth
- 0.5mm sizes and other shapes available upon request

### Dimensions (Metric)

A	B	C	D
66	110	84	15°

Gripping Diameter	Round	Hexagon	Square
3mm	D185E R03	-	-
4mm	D185E R04	-	-
5mm	D185E R05	D185E X05	D185E S05
6mm	D185E R06	-	D185E S06
7mm	D185E R07	D185E X07	D185E S07
8mm	D185E R08	D185E X08	D185E S08
9mm	D185E R09	-	-
10mm	D185E R10	D185E X10	D185E S10
11mm	D185E R11	D185E X11	-
12mm	D185E R12	D185E X12	D185E S12
13mm	D185E R13	D185E X13	-
14mm	D185E R14	D185E X14	D185E S14
15mm	D185E R15	D185E X15	D185E S15
16mm	D185E R16	D185E X16	D185E S16
17mm	D185E R17	D185E X17	-
18mm	D185E R18	D185E X18	D185E S18
19mm	D185E R19	D185E X19	-
20mm	D185E R20	D185E X20	D185E S20
21mm	D185E R21	-	-
22mm	D185E R22	D185E X22	D185E S22
23mm	D185E R23	-	-
24mm	D185E R24	D185E X24	-
25mm	D185E R25	D185E X25	D185E S25
26mm	D185E R26	D185E X26	-
27mm	D185E R27	D185E X27	-
28mm	D185E R28	-	-
29mm	D185E R29	-	-
30mm	D185E R30	D185E X30	D185E S30
31mm	D185E R31	-	-

Gripping Diameter	Round	Hexagon	Square
32mm	D185E R32	D185E X32	D185E S32
33mm	D185E R33	-	-
34mm	D185E R34	-	-
35mm	D185E R35	D185E X35	D185E S35
36mm	D185E R36	D185E X36	D185E S36
37mm	D185E R37	-	-
38mm	D185E R38	-	-
39mm	D185E R39	-	-
40mm	D185E R40	-	D185E S40
41mm	D185E R41	D185E X41	-
42mm	D185E R42	-	-
43mm	D185E R43	-	-
44mm	D185E R44	-	-
45mm	D185E R45	-	-
46mm	D185E R46	-	-
47mm	D185E R47	-	-
48mm	D185E R48	-	-
49mm	D185E R49	-	-
50mm	D185E R50	D185E X50	-
51mm	D185E R51	-	-
52mm	D185E R52	-	-
53mm	D185E R53	-	-
54mm	D185E R54	-	-
55mm	D185E R55	-	-
56mm	D185E R56	-	-
57mm	D185E R57	-	-
58mm	D185E R58	-	-
59mm	D185E R59	-	-
60mm	D185E R60	-	-

Emergency Collet with soft face and pilot hole 4mm diameter is available - Part No. **D185E-EMERGENCY**

## Spring Collets for CRL54 and QCRL54 Collet Chucks

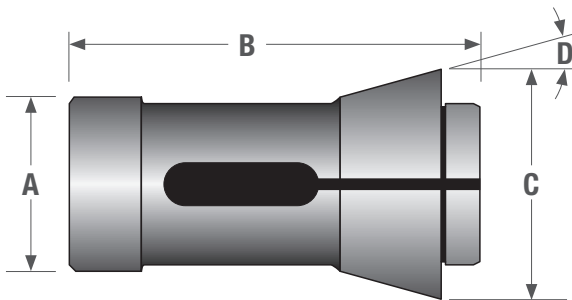

### D853 Spring Collets

- Type: 1503
- Round standard shape only
- Specify which gripping surface you require Annular serrations or smooth
- 0.5mm sizes and other shapes available upon request

### Dimensions (Metric)

A	B	C	D
60.28	125.4	88.1	15° 15'

Gripping Diameter	Round	Gripping Diameter	Round
2mm	D853E R02	29mm	D853E R29
3mm	D853E R03	30mm	D853E R30
4mm	D853E R04	31mm	D853E R31
5mm	D853E R05	32mm	D853E R32
6mm	D853E R06	33mm	D853E R33
7mm	D853E R07	34mm	D853E R34
8mm	D853E R08	35mm	D853E R35
9mm	D853E R09	36mm	D853E R36
10mm	D853E R10	37mm	D853E R37
11mm	D853E R11	38mm	D853E R38
12mm	D853E R12	39mm	D853E R39
13mm	D853E R13	40mm	D853E R40
14mm	D853E R14	41mm	D853E R41
15mm	D853E R15	42mm	D853E R42
16mm	D853E R16	43mm	D853E R43
17mm	D853E R17	44mm	D853E R44
18mm	D853E R18	45mm	D853E R45
19mm	D853E R19	46mm	D853E R46
20mm	D853E R20	47mm	D853E R47
21mm	D853E R21	48mm	D853E R48
22mm	D853E R22	49mm	D853E R49
23mm	D853E R23	50mm	D853E R50
24mm	D853E R24	51mm	D853E R51
25mm	D853E R25	52mm	D853E R52
26mm	D853E R26	53mm	D853E R53
27mm	D853E R27	54mm	D853E R54
28mm	D853E R28		

Emergency Collet with soft face and pilot hole 6mm dia. is available - Part No. **D853-EMERGENCY**

## Spring Collets for CRL80 and QCRL80 Collet Chucks

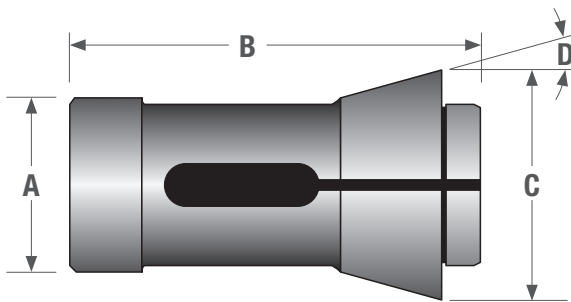

### D193E Spring Collets

- DIN 6343 Type: H-47
- Round standard shape only
- Specify which gripping surface you require – Annular Serrations or Smooth
- 0.5mm sizes and other shapes available upon request

### Dimensions (Metric)

A	B	C	D
90	130	107	15°

Gripping Diameter	Round
12mm	D193E R12
13mm	D193E R13
14mm	D193E R14
15mm	D193E R15
16mm	D193E R16
17mm	D193E R17
18mm	D193E R18
19mm	D193E R19
20mm	D193E R20
21mm	D193E R21
22mm	D193E R22
23mm	D193E R23
24mm	D193E R24
25mm	D193E R25
26mm	D193E R26
27mm	D193E R27
28mm	D193E R28
29mm	D193E R29
30mm	D193E R30
31mm	D193E R31
32mm	D193E R32
33mm	D193E R33
34mm	D193E R34
35mm	D193E R35
36mm	D193E R36
37mm	D193E R37
38mm	D193E R38
39mm	D193E R39
40mm	D193E R40
41mm	D193E R41
42mm	D193E R42
43mm	D193E R43
44mm	D193E R44
45mm	D193E R45
46mm	D193E R46

Gripping Diameter	Round
47mm	D193E R47
48mm	D193E R48
49mm	D193E R49
50mm	D193E R50
51mm	D193E R51
52mm	D193E R52
53mm	D193E R53
54mm	D193E R54
55mm	D193E R55
56mm	D193E R56
57mm	D193E R57
58mm	D193E R58
59mm	D193E R59
60mm	D193E R60
61mm	D193E R61
62mm	D193E R62
63mm	D193E R63
64mm	D193E R64
65mm	D193E R65
66mm	D193E R66
67mm	D193E R67
68mm	D193E R68
69mm	D193E R69
70mm	D193E R70
71mm	D193E R71
72mm	D193E R72
73mm	D193E R73
74mm	D193E R74
75mm	D193E R75
76mm	D193E R76
77mm	D193E R77
78mm	D193E R78
79mm	D193E R79
80mm	D193E R80

Emergency Collet with soft face and pilot hole 10mm dia. is available - Part No. **D193E-EMERGENCY**

## QC & C Series Standard Accessories

### Work Stops

- Stops can be provided to allow for accurate z-axis positioning of short workpieces within the collet chuck.
- A threaded stud is provided for easy adjustment to suit your work piece
- All stops are easily installed from the front face utilising a side bolt to hold the stop securely in place.
- These stops can be installed on all QC & C series collet chucks.
- Full length spindle stops can also be provided for long work pieces, these can utilise the entire length of your machine spindle, please contact your Klamp supplier to see the maximum length stop your machine could accommodate.

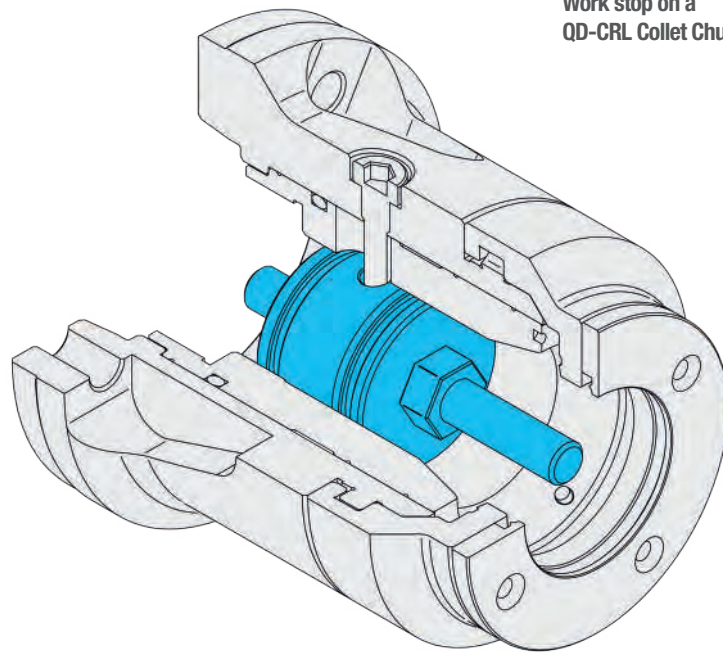

Work stop on a QD-CRL Collet Chuck

### Spring Ejectors

- Standard spring ejectors for QC & C series are used for second-spindle operations to expel finished workpieces into the parts catcher.
- Many variants of spring ejector are available to suit your production process.
- Spring ejectors can be installed on all QC & C series collet chucks.
- Full length hydraulic or pneumatic ejectors can also be provided for long work pieces, this can utilise the entire length of your machine spindle, please contact your Klamp supplier to see the maximum length stop your machine could accommodate.

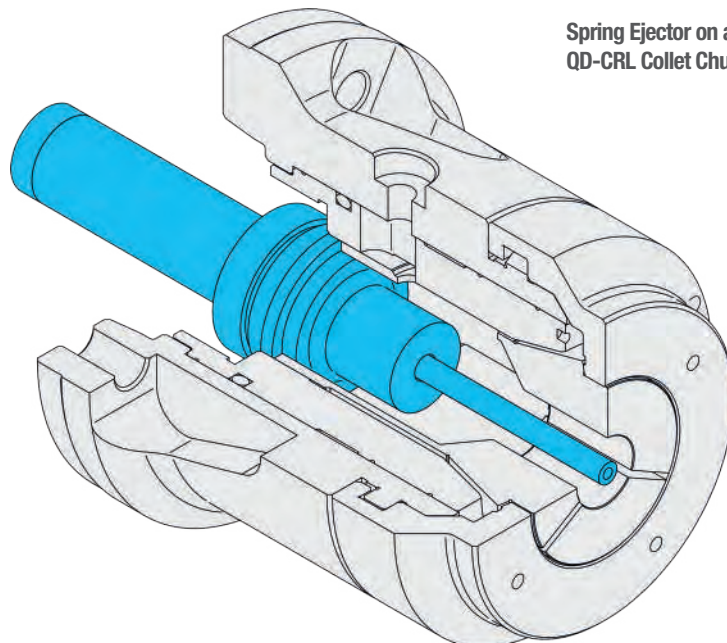

Spring Ejector on a QD-CRL Collet Chuck





# Varibore Collets

to suit QC & C Series

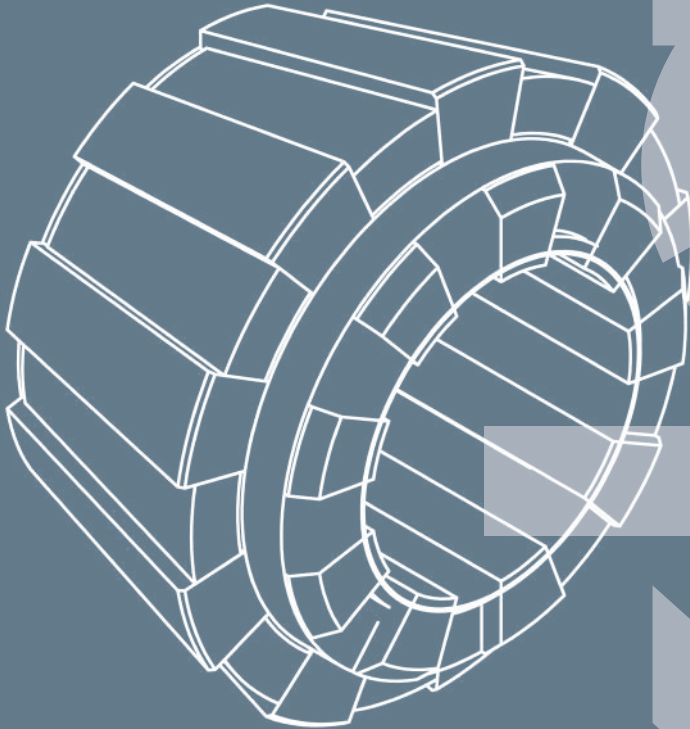
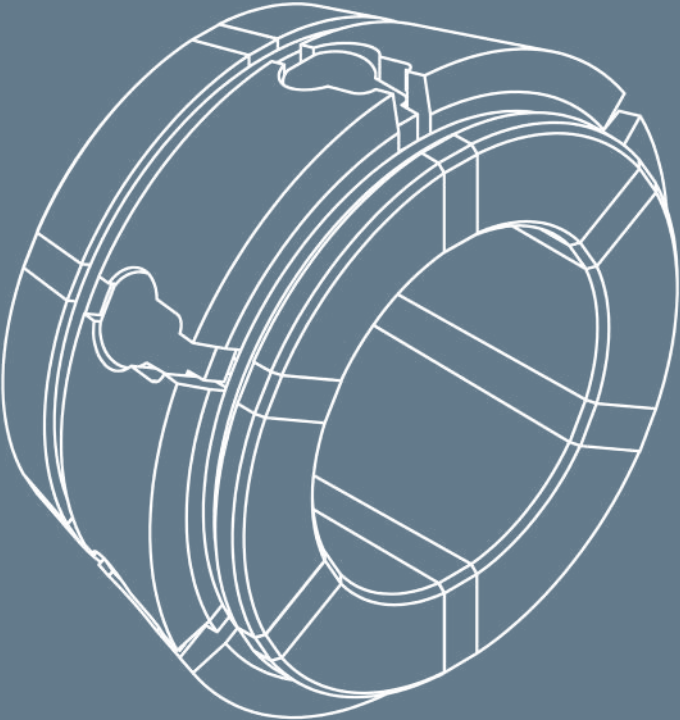

Varibore Collets  
QC & C Series

## Varibore Collets for CRS54, QCRL54, CRS66, QCRS66, QCRL66 & QCRS80 Collet Chucks

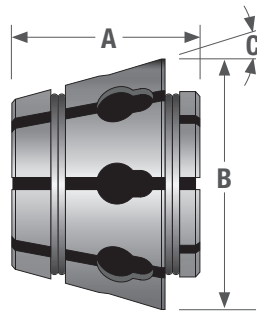

### Varibore Collets

- Round, Hexagon or Square
- Specify which gripping surface you require – Supergrip Serrations (Heavy duty), Annular Serrations or Smooth
- Other shapes available upon request

### Dimensions (Metric)

Part No.	A	B	C
D120	62.7	88	15°
D285	73.2	99.3	15°
D175	80	120	15°

Gripping Range		D120 for CRS54 & QCRL54			D285 for CRS66, QCRS66 & QCRL66			D175 for QCRS80		
Inch	mm	Round	Hexagon	Square	Round	Hexagon	Square	Round	Hexagon	Square
1/16 - 3/16	1.58 - 4.76	D120R-D01	-	-	-	-	-	-	-	-
1/8 - 1/4	3.17 - 6.35	D120R-D02	D120X-D69	D120S-D87	D285R-E02	D285X-E69	D285S-E87	-	-	-
1/4 - 3/8	6.35 - 9.52	D120R-D03	D120X-D70	D120S-D88	D285R-E03	D285X-E70	D285S-E88	-	-	-
3/8 - 1/2	9.52 - 12.70	D120R-D04	D120X-D71	D120S-D89	D285R-E04	D285X-E71	D285S-E89	-	-	-
1/2 - 5/8	12.70 - 15.87	D120R-D05	D120X-D72	D120S-D90	D285R-E05	D285X-E72	D285S-E90	D175R-F05	D175X-F72	D175S-F100
5/8 - 3/4	15.87 - 19.05	D120R-D06	D120X-D73	D120S-D91	D285R-E06	D285X-E73	D285S-E91	D175R-F06	D175X-F73	D175S-F101
3/4 - 7/8	19.05 - 22.22	D120R-D07	D120X-D74	D120S-D92	D285R-E07	D285X-E74	D285S-E92	D175R-F07	D175X-F74	D175S-F102
7/8 - 1	22.22 - 25.40	D120R-D08	D120X-D75	D120S-D93	D285R-E08	D285X-E75	D285S-E93	D175R-F08	D175X-F75	D175S-F103
1 - 1.1/8	25.40 - 28.57	D120R-D09	D120X-D76	D120S-D94	D285R-E09	D285X-E76	D285S-E94	D175R-F09	D175X-F76	D175S-F104
1.1/8 - 1.1/4	28.57 - 31.75	D120R-D10	D120X-D77	D120S-D95	D285R-E10	D285X-E77	D285S-E95	D175R-F10	D175X-F77	D175S-F105
1.1/4 - 1.3/8	31.75 - 34.92	D120R-D11	D120X-D78	D120S-D96	D285R-E11	D285X-E78	D285S-E96	D175R-F11	D175X-F78	D175S-F106
1.3/8 - 1.1/2	34.92 - 38.10	D120R-D12	D120X-D79	D120S-D97	D285R-E12	D285X-E79	D285S-E97	D175R-F12	D175X-F79	D175S-F107
1.1/2 - 1.5/8	38.10 - 41.27	D120R-D13	D120X-D80	D120S-D98	D285R-E13	D285X-E80	D285S-E98	D175R-F13	D175X-F80	D175S-F108
1.5/8 - 1.3/4	41.27 - 44.45	D120R-D14	D120X-D81	-	D285R-E14	D285X-E81	D285S-E99	D175R-F14	D175X-F81	D175S-F109
1.3/4 - 1.7/8	44.45 - 47.62	D120R-D15	D120X-D82	-	D285R-E15	D285X-E82	-	D175R-F15	D175X-F82	D175S-F110
1.7/8 - 2	47.62 - 50.80	D120R-D16	D120X-D83	-	D285R-E16	D285X-E83	-	D175R-F16	D175X-F83	D175S-F111
2 - 2.1/8	50.80 - 53.97	D120R-D17	-	-	D285R-E17	D285X-E84	-	D175R-F17	D175X-F84	D175S-F112
2.1/8 - 2.1/4	53.97 - 57.15	-	-	-	D285R-E18	D285X-E85	-	D175R-F18	D175X-F85	-
2.1/4 - 2.3/8	57.15 - 60.32	-	-	-	D285R-E19	-	-	D175R-F19	D175X-F86	-
2.3/8 - 2.1/2	60.32 - 63.50	-	-	-	D285R-E20	-	-	D175R-F20	D175X-F87	-
2.1/2 - 2.5/8	63.50 - 66.67	-	-	-	D285R-E21	-	-	D175R-F21	D175X-F88	-
2.5/8 - 2.3/4	66.67 - 69.85	-	-	-	-	-	-	D175R-F22	-	-
2.3/4 - 2.7/8	69.85 - 73.02	-	-	-	-	-	-	D175R-F23	-	-
2.7/8 - 3	73.02 - 76.20	-	-	-	-	-	-	D175R-F24	-	-
3 - 3.1/8	76.20 - 79.37	-	-	-	-	-	-	D175R-F25	-	-

Emergency Collets with soft face and pilot hole is available for all types

## Varibore Collets for CRS36, CRL42, QCRL42, CRL60, QCRL60, CRL80 & QCRL80 Collet Chucks

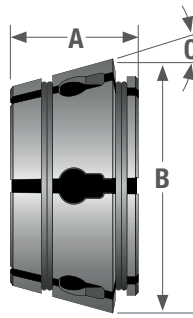

### Varibore Collets - Type: DIN 6343

- Round, Hexagon or Square
- Specify which gripping surface you require – Supergrip Serrations (Heavy duty), Annular serrations or Smooth
- Other shapes available upon request

### Dimensions (Metric)

Part No.	A	B	C
D671	38	56.5	14.75°
D673	39	61.5	14.75°
D677	45	85.5	14.75°
D660	48	1087.5	14.75°

Gripping Range	D671 DIN for CRS36			D673 DIN for CRL42 & QCRL42			D677 DIN for CRL60 & QCRL60			D660 DIN for CRL80 & QCRL80		
	mm	Round	Hexagon	Square	Round	Hexagon	Square	Round	Hexagon	Square	Round	Hexagon
4 - 6	D671-R06	D671-X06	D671-S06	D673-R06	D673-X06	D673-S06	-	-	-	-	-	-
6 - 8	D671-R08	D671-X08	D671-S08	D673-R08	D673-X08	D673-S08	D677-R08	D677-X08	D677-S08	-	-	-
8 - 10	D671-R10	D671-X10	D671-S10	D673-R10	D673-X10	D673-S10	D677-R10	D677-X10	D677-S10	-	-	-
10 - 12	D671-R12	D671-X12	D671-S12	D673-R12	D673-X12	D673-S12	D677-R12	D677-X12	D677-S12	-	-	-
12 - 14	D671-R14	D671-X14	D671-S14	D673-R14	D673-X14	D673-S14	D677-R14	D677-X14	D677-S14	D660-R14	D660-X14	-
14 - 16	D671-R16	D671-X16	D671-S16	D673-R16	D673-X16	D673-S16	D677-R16	D677-X16	D677-S16	D660-R16	D660-X16	-
16 - 18	D671-R18	D671-X18	D671-S18	D673-R18	D673-X18	D673-S18	D677-R18	D677-X18	D677-S18	D660-R18	D660-X18	-
18 - 20	D671-R20	D671-X20	D671-S20	D673-R20	D673-X20	D673-S20	D677-R20	D677-X20	D677-S20	D660-R20	D660-X20	-
20 - 22	D671-R22	D671-X22	D671-S22	D673-R22	D673-X22	D673-S22	D677-R22	D677-X22	D677-S22	D660-R22	D660-X22	-
22 - 24	D671-R24	D671-X24	D671-S24	D673-R24	D673-X24	D673-S24	D677-R24	D677-X24	D677-S24	D660-R24	D660-X24	-
24 - 26	D671-R26	D671-X26	-	D673-R26	D673-X26	D673-S26	D677-R26	D677-X26	D677-S26	D660-R26	D660-X26	-
26 - 28	D671-R28	D671-X28	-	D673-R28	D673-X28	D673-S28	D677-R28	D677-X28	D677-S28	D660-R28	D660-X28	-
28 - 30	D671-R30	-	-	D673-R30	D673-X30	D673-S30	D677-R30	D677-X30	D677-S30	D660-R30	D660-X30	-
30 - 32	D671-R32	-	-	D673-R32	D673-X32	-	D677-R32	D677-X32	D677-S32	D660-R32	D660-X32	-
32 - 34	D671-R34	-	-	D673-R34	D673-X34	-	D677-R34	D677-X34	D677-S34	D660-R34	D660-X34	-
34 - 36	D671-R36	-	-	D673-R36	D673-X36	-	D677-R36	D677-X36	D677-S36	D660-R36	D660-X36	-
36 - 38	-	-	-	D673-R38	-	-	D677-R38	D677-X38	D677-S38	D660-R38	D660-X38	-
38 - 40	-	-	-	D673-R40	-	-	D677-R40	D677-X40	D677-S40	D660-R40	D660-X40	-
40 - 42	-	-	-	D673-R42	-	-	D677-R42	D677-X42	D677-S42	D660-R42	D660-X42	-
42 - 44	-	-	-	-	-	-	D677-R44	D677-X44	-	D660-R44	D660-X44	-
44 - 46	-	-	-	-	-	-	D677-R46	D677-X46	-	D660-R46	D660-X46	-
46 - 48	-	-	-	-	-	-	D677-R48	D677-X48	-	D660-R48	D660-X48	-
48 - 50	-	-	-	-	-	-	D677-R50	D677-X50	-	D660-R50	D660-X50	-
50 - 52	-	-	-	-	-	-	D677-R52	D677-X52	-	D660-R52	D660-X52	-
52 - 54	-	-	-	-	-	-	D677-R54	-	-	D660-R54	D660-X54	-
54 - 56	-	-	-	-	-	-	D677-R56	-	-	D660-R56	D660-X56	-
56 - 58	-	-	-	-	-	-	D677-R58	-	-	D660-R58	D660-X58	-
58 - 60	-	-	-	-	-	-	D677-R60	-	-	D660-R60	D660-X60	-
60 - 62	-	-	-	-	-	-	-	-	-	D660-R62	D660-X62	-
62 - 64	-	-	-	-	-	-	-	-	-	D660-R64	D660-X64	-
64 - 66	-	-	-	-	-	-	-	-	-	D660-R66	D660-X66	-
66 - 68	-	-	-	-	-	-	-	-	-	D660-R68	D660-X68	-
68 - 70	-	-	-	-	-	-	-	-	-	D660-R70	-	-
70 - 72	-	-	-	-	-	-	-	-	-	D660-R72	-	-
72 - 74	-	-	-	-	-	-	-	-	-	D660-R74	-	-
74 - 76	-	-	-	-	-	-	-	-	-	D660-R76	-	-
76 - 78	-	-	-	-	-	-	-	-	-	D660-R78	-	-
78 - 80	-	-	-	-	-	-	-	-	-	D660-R80	-	-

Emergency Collets with soft face and pilot hole is available for all types

## Rubber-Flex Collets

### Five spring collets into one Rubber-Flex collet

With same accuracy specification as standard spring collets, the Elastic rubber-metal vulcanization allows a clamping range of +/- 1mm to the nominal diameter. This reduces the need for numerous changeovers when

clamping different diameters, saving your time. Instead of purchasing four additional spring collets to cover the same diameter range you can save up to 50% in investment costs with one Rubber-Flex collet.

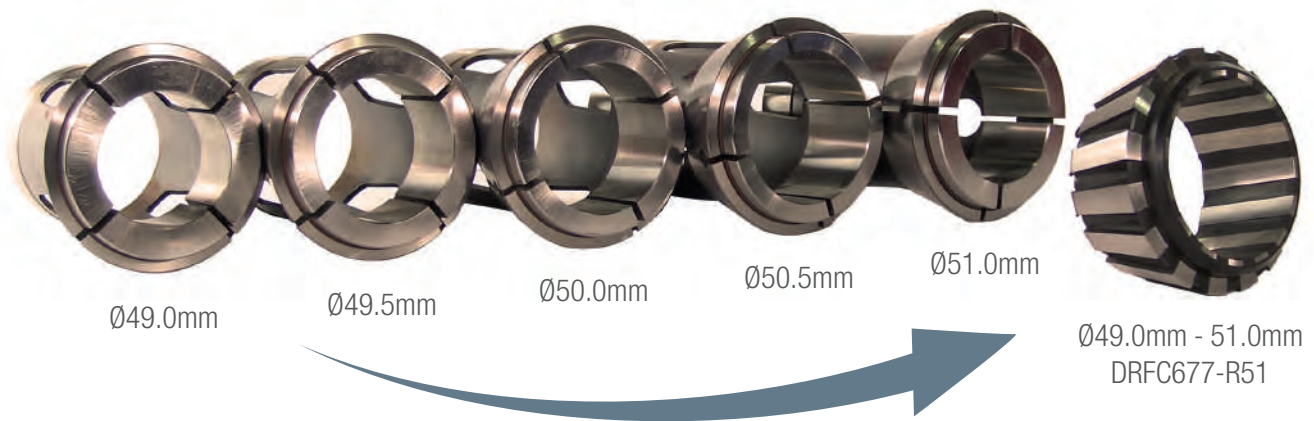

### Versatile

Rubber-Flex collets, type DRFC 673 (173E equivalent) and DRFC 677 (185E equivalent) are available in "Smooth" or "Full Grip" design. "Smooth" collets are ideal for 2nd Operation work or sensitive workpieces with surfaces that should not be marked. "Full Grip" collets have wider steel segments provide a higher rigidity. These double-serrated collets have an increased clamping force and are especially designed to machine bar material with wide clamping tolerances and high torque.

Due to the unique design Rubber-Flex collets also increase the diameters that your collet chuck can clamp. For example, a Q-CRL42 collet chuck can clamp up to 45mm from the standard 42mm and for a Q-CRL60 collet chuck can clamp up to 65mm from the standard 60mm using Rubber-Flex.

- Perfect sealing against coolant and swarf
- More surface area = higher torque transfer
- Coolant and temperature resistant up to 100° C
- Gentle surface clamping with parallel closing of steel segments



## Rubber-Flex Collets for CRL42, QCRL42, CRS60, CRL60, QCRL60 Collet Chucks

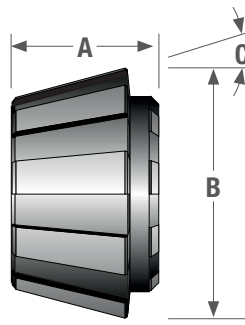
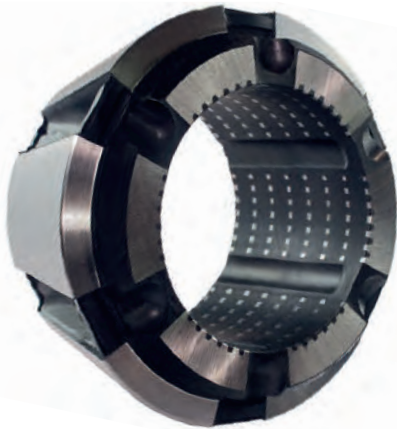

### Rubberflex Collets – Type: DIN 6343

- Round, Hexagon or Square
- Specify which gripping surface you require – Full Grip or Smooth  
Smooth Type – **DRFCXXX-RXX**  
Full Grip Type – **DRFCXXX-RXX/R**

### Dimensions (Metric)

Part No.	A	B	C
DRFC673	39	61.5	14.75°
DRFC677	45	85.5	14.75°

Gripping Range mm	DRFC673 DIN for CRL42 & QCRL42	DRFC677 DIN for CRS60, CRL60 & QCRL60
	Round	Round
7 - 9	DRFC673-R09	-
9 - 11	DRFC673-R11	-
11 - 13	DRFC673-R13*	-
13 - 15	DRFC673-R15*	-
15 - 17	DRFC673-R17*	-
17 - 19	DRFC673-R19*	-
19 - 21	DRFC673-R21*	DRFC677-R21*
21 - 23	DRFC673-R23*	DRFC677-R23*
23 - 25	DRFC673-R25*	DRFC677-R25*
25 - 27	DRFC673-R27*	DRFC677-R27*
27 - 29	DRFC673-R29*	DRFC677-R29*
29 - 31	DRFC673-R31*	DRFC677-R31*
31 - 33	DRFC673-R33*	DRFC677-R33*
33 - 35	DRFC673-R35*	DRFC677-R35*
35 - 37	DRFC673-R37*	DRFC677-R37*
37 - 39	DRFC673-R39*	DRFC677-R39*
39 - 41	DRFC673-R41*	DRFC677-R41*
41 - 43	DRFC673-R43*	DRFC677-R43*
43 - 45	DRFC673-R45	DRFC677-R45*
45 - 47	-	DRFC677-R47*
47 - 49	-	DRFC677-R49*
49 - 51	-	DRFC677-R51*
51 - 53	-	DRFC677-R53*
53 - 55	-	DRFC677-R55*
55 - 57	-	DRFC677-R57*
57 - 59	-	DRFC677-R59*
59 - 61	-	DRFC677-R61*
61 - 63	-	DRFC677-R63
63 - 65	-	DRFC677-R65

\*Available as full grip & smooth specification, otherwise can only be supplied in smooth specification



# Collet Chucks

## D Series



## Pull Back Series Power Collet Chuck for Bar Machining

### First Operation Collet Chuck

Klamp DHP collet chucks are suitable for collets which have a +/-0.5mm gripping range. Allowing the collet chuck to handle rough and unfinished bar, preparing it for a high accuracy second operation.

### Pull Back Action

The Collet pulled into the chuck to close and pushed out to open. This action means that back stops cannot be provided and must be used where accurate axial positioning is not important.

### Problem Free Installation

Klamp collet chucks are provided with mounting bolts and a custom-machined drawtube connector allowing you to start using the Klamp collet chuck straight out of the box.

### Quick & Easy Mounting

Klamp collet chucks mount directly to the lathe spindle or use a precision adaptor plate to ensure a consistent mounting without the need for correction. The precision fit of the Klamp collet chuck enhances the rigidity of the overall system. The need for adjustment is minimal, meaning less machine down-time.

### Long Service Life

All Klamp collet chucks are case hardened, optimising the rigidity, strength and durability.

### Short Body/Wide Range

DC Varibore collets allow for a compact body design maximising the lathe work envelope. Gripping capacities of the series range from 4mm to 80mm.

### Low Profile

Small nose diameter to provide excellent tool clearance.

### Fully Sealed

No grease required to operate the collet chuck. O-ring seals are incorporated within the design to prevent coolant and chip ingress.

### High Speed

Direct mount design ensures high concentricity that is suitable for higher speed operations that are not appropriate for conventional 3-jaw chuck due to the negative effects of centrifugal force.



### Suitable for DC Varibore Collet Types

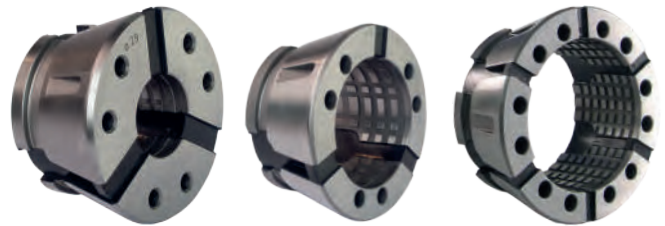

Klamp DHP collet chucks accept DC Varibore Collets that have the same accuracy specification as spring collets whilst maintaining a gripping range of +/- 0.5mm. Supplied with either smooth or serrated gripping surface. Serrated collets are ideal for aggressive first operation gripping of rough bar work.

Vulcanized rubber between the hardened steel collet segments provides excellent protection against coolant and chip ingress. Counter boring and special profile shapes are available upon request.

### Ultra-Fast 10 Second Collet Changes



Insert & Unlock DC Collet



Remove DC Collet



Insert DC Collet



Lock & Remove DC



## Pull Back Series Power Collet Chuck for Bar Machining

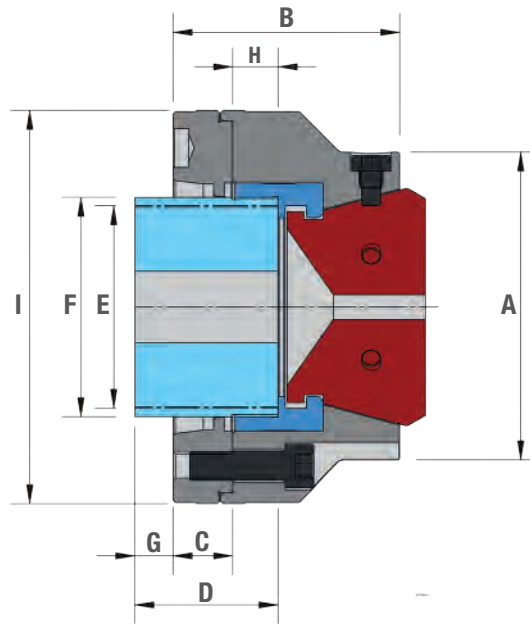

KLAMP Type	DHP42		DHP52			DHP65			DHP80					
Mounting	Z140	A5	A5	A6	A8	A5	A6	A8	Z220	A6	A8	A11		
Part Number	DHP42	DHP42A5	DHP52A5	DHP52A6	DHP52A8	DHP65A5	DHP65A6	DHP65A8	DHP80	DHP80A6	DHP80A8	DHP80A11		
Varibore Collet Type	DC42		DC52			DC65			DC80					
Varibore Collet Gripping range*	Minimum	4	4			4			7					
	Maximum	42	52			65			80					
Varibore Collet Increments	1		1			1			1					
A	100		120			130			160					
B	110		89		109	95		115	109.5	134.5	127.5	156.5		
C	15		25		45	25		45	NA	25	18	47		
D	60		60			60			70	68	70			
E Maximum	M58 x 2.0		M70 x 2.0		M85 x 2.0		M70 x 2.0		M85 x 2.0		M105 x 2.0			
F	65		79		92		79		92		115			
G Maximum	25	10	20.5	16	-4	44		-4	32	5	14	-15		
G Minimum	20.5	5.5	16	11.5	0.5	39.5		0.5	36.5	9.5	18.5	-10.5		
H	39.5		19			19			38					
I	150		165		210	165		210	230		280			
Sleeve stroke	4.5		4.5			4.5			4.5					
Max. input force	kN		35		40	45			50					
Max. Gripping Force	kN		60		94	105			115					
Max. Speed	min <sup>-1</sup>		6000		6500	6000			5500					
Net Weight	kg		8	9	11.3	11.6	16	11.6	11.8	16.3	24.6	29.6	27.5	34
Matching Kitagawa Cylinders	S1246 SS1246 SR1146		S1552 SS1452 SR1453			S1875 SS1771 SR1566			S2091 SS1881 SR1781					



## Fixed Length Series Power Collet Chuck for Bar Machining

### First & Second Operation Collet Chuck

Designed with a fixed length actuation system that ensures the collet is held stationary. Allowing the collet chuck to be used in bar feeding operations and highly accurate second operations. Klamp DKF collet chucks are suitable for collets which have a +/-0.5mm gripping range.

### Fixed Length Collet

Workpiece remains in a fixed position during actuation, allowing for precise z-axis positioning. A tapered sleeve is pushed forward, compressing the collet and gripping the workpiece.

### Problem Free Installation

Klamp collet chucks are provided with mounting bolts and a custom-machined drawtube connector allowing you to start using the Klamp collet chuck straight out of the box.

### Quick & Easy Mounting

Klamp collet chucks mount directly to the lathe spindle or use a precision adaptor plate to ensure a consistent mounting without the need for correction. The precision fit of the Klamp collet chuck enhances the rigidity of the overall system. The need for adjustment is minimal, meaning less machine down-time.

### Long Service Life

All Klamp collet chucks are case hardened, optimising the rigidity, strength and durability.

### Short Body/Wide Range

DC Varibore collets allow for a compact body design maximising the lathe work envelope. Gripping capacities of the series range from 4mm to 65mm.

### Low-Profile Nose

Klamp DKF Series Collet Chucks have a small nose diameter for superior tool clearance.

### Fully Sealed

No grease required to operate the collet chuck. O-ring seals are incorporated within the design to prevent coolant and chip ingress.

### High Speed

Direct mount design ensures high concentricity that is suitable for higher speed operations that are not appropriate for conventional 3-jaw chuck due to the negative effects of centrifugal force.

### Designed for Bar Pushers/Barfeeders

Fixed-length Klamp collet chucks are designed to work with bar loaders and bar feeders by not interfering with the process of the bar feeder action.

### Ultra-Fast 10 Second Collet Changes



Insert & Unlock DC Collet



Remove DC Collet



Insert DC Collet



Lock & Remove DC



### Suitable for DC Varibore Collet Types



Klamp DKF collet chucks accept DC Varibore Collets that have the same accuracy specification as spring collets whilst maintaining a gripping range of +/- 0.5mm. Supplied with either smooth or serrated gripping surface. Serrated collets are ideal for aggressive first operation gripping of rough bar work.

Vulcanized rubber between the hardened steel collet segments provides excellent protection against coolant and chip ingress. Counter boring and special profile shapes are available upon request.



Fixed Length Series Power Collet Chuck for Bar Machining

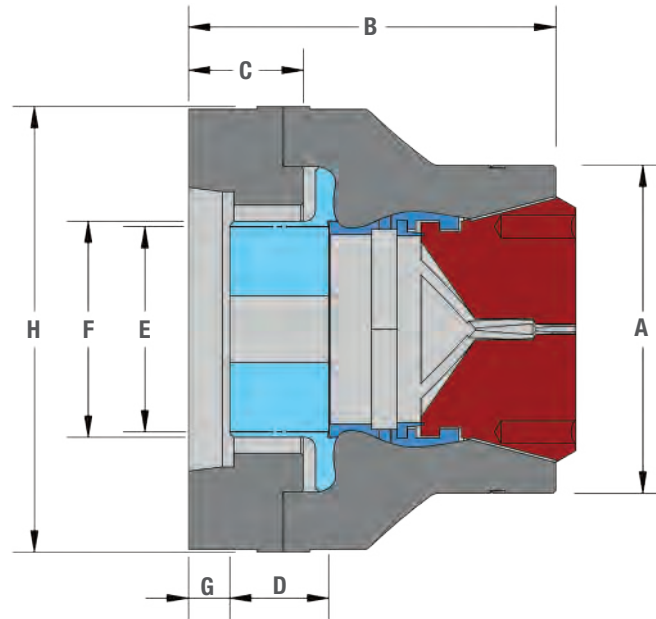

KLAMP Type	DKF42			DKF52			DKF65				DKF80				
Mounting	Z140	A5	A6	Z140	A5	A6	Z140	A5	A6	A8	Z220	A6	A8	A11	
Part Number	DKF42	DKF42A5	DKF42A6	DKF52	DKF52A5	DKF52A6	DKF65	DKF65A5	DKF65A6	DKF65A8	DKF80	DKF80A6	DKF80A8	DKF80A11	
Varibore Collet Type	DC42			DC52			DC65				DC80				
Varibore Collet Gripping range*	Min.	3			4			4				5			
	Max.	42			52			65				80			
Varibore Collet Increments	1			1			1				1				
A	103			106			123				138				
B	121			132	137		137.5		161.5		146.2	164.25	142	186.25	
C	42.5			44.5	49.5		43		67		50	67.8	45.75	47	
D	30.5			31			37				51.5				
E Maximum	M50			M60			M75	M74	M75		M80				
	x 2.0			x 2.0			x 2.0	x 2.0	x 2.0		x 2.0				
F	66			68			81	79.5	81	81	97				
G Maximum	12	17		14	24		10.5	15.5		39.5	2	27	4.75	49	
	7.5	12.5		9.5	19.5		6	11		35	2.5	22.5	0.25	44.5	
H	152		157	162			167				201.5	232	207	280	
Sleeve stroke	4.5			4.5			4.5				4.5				
Max. input force	40			40			45				50				
Max. Gripping Force	94			94			105				114				
Max. Speed	6500			6500			6000				5000				
Net Weight	11			12			13	14	13	19	22	27	21	34	
Matching Kitagawa Cylinders	S1246 SS1246 SR1146			S1552 SS1452 SR1453			S1875 SS1770 SR1566				S2091 SS1881 SR1781				





# DC Collets

to suit **D Series**

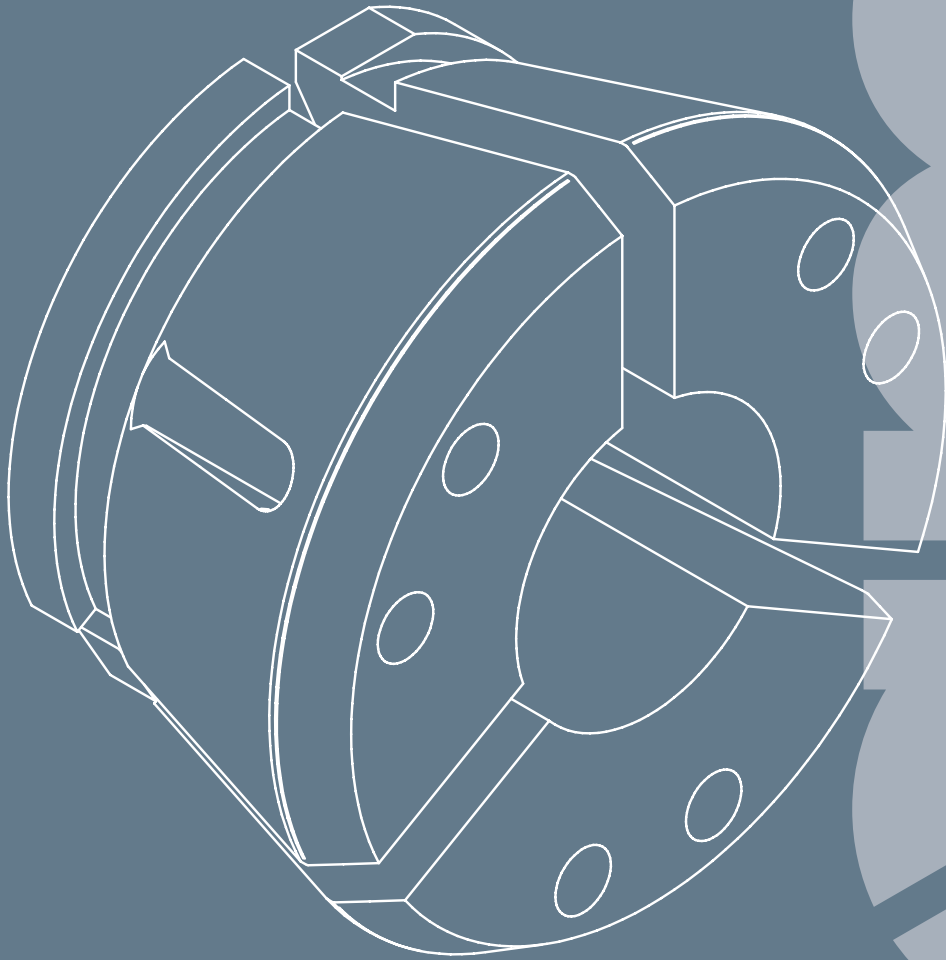

## DC Quick Change Collets to Suit DHP42 Collet Chucks

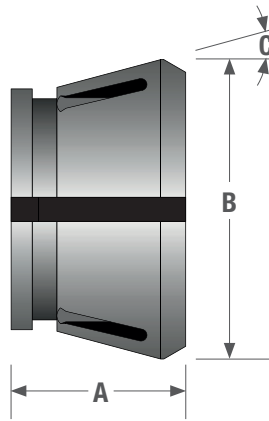

### DC42 Varibore Collets

- Round, Hexagon, Square or Emergency types available
- Please specify which gripping surface you require – Serrated or Smooth
- Clamping tolerance of +/- 0.5mm
- Counter boring and special profile shapes are available upon request

### Dimensions (Metric)

Part No.	A	B	C
DC42	47	79.3	15°
DC42S	42	79.3	15°

### DC42 Round Collets

Nominal Gripping Diameter	Serrated Part Number	Smooth Part Number
3mm	-	DC42S-R03
4mm	-	DC42S-R04
5mm	-	DC42S-R05
6mm	-	DC42S-R06
7mm	-	DC42S-R07
8mm	DC42-R08*	DC42S-R08
9mm	DC42-R09*	DC42S-R09
10mm	DC42-R10*	DC42S-R10
11mm	DC42-R11	DC42S-R11
12mm	DC42-R12	DC42S-R12
13mm	DC42-R13	DC42S-R13
14mm	DC42-R14	DC42S-R14
15mm	DC42-R15	DC42S-R15
16mm	DC42-R16	DC42S-R16

Nominal Gripping Diameter	Serrated Part Number	Smooth Part Number
17mm	DC42-R17	DC42S-R17
18mm	DC42-R18	DC42S-R18
19mm	DC42-R19	DC42S-R19
20mm	DC42-R20	DC42S-R20
21mm	DC42-R21	DC42S-R21
22mm	DC42-R22	DC42S-R22
23mm	DC42-R23	DC42S-R23
24mm	DC42-R24	DC42S-R24
25mm	DC42-R25	DC42S-R25
26mm	DC42-R26	DC42S-R26
27mm	DC42-R27	DC42S-R27
28mm	DC42-R28	DC42S-R28
29mm	DC42-R29	DC42S-R29

Nominal Gripping Diameter	Serrated Part Number	Smooth Part Number
30mm	DC42-R30	DC42S-R30
31mm	DC42-R31	DC42S-R31
32mm	DC42-R32	DC42S-R32
33mm	DC42-R33	DC42S-R33
34mm	DC42-R34	DC42S-R34
35mm	DC42-R35	DC42S-R35
36mm	DC42-R36	DC42S-R36
37mm	DC42-R37	DC42S-R37
38mm	DC42-R38	DC42S-R38
39mm	DC42-R39	DC42S-R39
40mm	DC42-R40	DC42S-R40
41mm	DC42-R41	DC42S-R41
42mm	DC42-R42	DC42S-R42

\* Radial grooves only - larger sizes have axial and radial grooves

### DC42 Hexagon Collets

Available from 7mm to 38mm across flats sides of the hexagon in 1mm increments. Part number is **DC42-X\*\***. Please state which size you require, smooth (7-38mm) or serrated (8-38mm) gripping surface is available.

### DC42 Square Collets

Available from 7mm to 28mm across flats sides of the square in 1mm increments. Part number is **DC42-S\*\***. Please state which size you require, smooth (7-28mm) or serrated (8-28mm) gripping surface is available.

### DC42 Emergency Collets

Available only with 5mm, 15mm or 30mm pilot holes. Part number is **DC42-E\*\*** Please state which size you require.

## DC Quick Change Collets to Suit DHP52 Collet Chucks

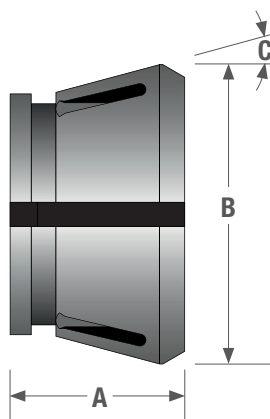

### DC52 Varibore Collets

- Round, Hexagon, Square or Emergency types available
- Please specify which gripping surface you require – Serrated or Smooth
- Clamping tolerance of +/- 0.5mm
- Counter boring and special profile shapes are available upon request

### Dimensions (Metric)

Part No.	A	B	C
DC52	46	79.2	15°

### DC52 Round Collets

Nominal Gripping Diameter	Serrated Part Number	Smooth Part Number
3mm	-	DC52S-R03
4mm	-	DC52S-R04
5mm	-	DC52S-R05
6mm	-	DC52S-R06
7mm	-	DC52S-R07
8mm	DC52-R08*	DC52S-R08
9mm	DC52-R09*	DC52S-R09
10mm	DC52-R10*	DC52S-R10
11mm	DC52-R11	DC52S-R11
12mm	DC52-R12	DC52S-R12
13mm	DC52-R13	DC52S-R13
14mm	DC52-R14	DC52S-R14
15mm	DC52-R15	DC52S-R15
16mm	DC52-R16	DC52S-R16
17mm	DC52-R17	DC52S-R17
18mm	DC52-R18	DC52S-R18
19mm	DC52-R19	DC52S-R19

Nominal Gripping Diameter	Serrated Part Number	Smooth Part Number
20mm	DC52-R20	DC52S-R20
21mm	DC52-R21	DC52S-R21
22mm	DC52-R22	DC52S-R22
23mm	DC52-R23	DC52S-R23
24mm	DC52-R24	DC52S-R24
25mm	DC52-R25	DC52S-R25
26mm	DC52-R26	DC52S-R26
27mm	DC52-R27	DC52S-R27
28mm	DC52-R28	DC52S-R28
29mm	DC52-R29	DC52S-R29
30mm	DC52-R30	DC52S-R30
31mm	DC52-R31	DC52S-R31
32mm	DC52-R32	DC52S-R32
33mm	DC52-R33	DC52S-R33
34mm	DC52-R34	DC52S-R34
35mm	DC52-R35	DC52S-R35
36mm	DC52-R36	DC52S-R36

Nominal Gripping Diameter	Serrated Part Number	Smooth Part Number
37mm	DC52-R37	DC52S-R37
38mm	DC52-R38	DC52S-R38
39mm	DC52-R39	DC52S-R39
40mm	DC52-R40	DC52S-R40
41mm	DC52-R41	DC52S-R41
42mm	DC52-R42	DC52S-R42
43mm	DC52-R43	DC52S-R43
44mm	DC52-R44	DC52S-R44
45mm	DC52-R45	DC52S-R45
46mm	DC52-R46	DC52S-R46
47mm	DC52-R47	DC52S-R47
48mm	DC52-R48	DC52S-R48
49mm	DC52-R49	DC52S-R49
50mm	DC52-R50	DC52S-R50
51mm	DC52-R51	DC52S-R51
52mm	DC52-R52	DC52S-R52

\* Radial grooves only - larger sizes have axial and radial grooves

### DC52 Hexagon Collets

Available from 7mm to 45mm across flats sides of the hexagon in 1mm increments. Part number is **DC52-X\*\***. Please state which size you require, smooth (7-45mm) or serrated (8-45mm) gripping surface is available.

### DC52 Square Collets

Available from 7mm to 36mm across flats sides of the square in 1mm increments. Part number is **DC52-S\*\***. Please state which size you require, smooth (7-36mm) or serrated (8-36mm) gripping surface is available.

### DC52 Emergency Collets

Available only with 5mm, 15mm or 30mm pilot holes. Part number is **DC52-E\*\***. Please state which size you require.

## DC Quick Change Collets to Suit DHP65/DHF65/DRF65 Collet Chucks

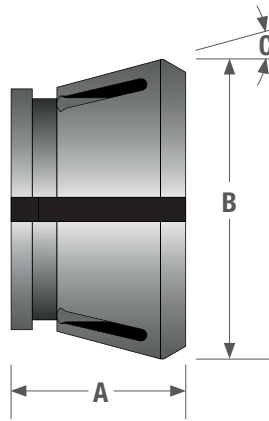

### DC65 Varibore Collets

- Round, Hexagon, Square or Emergency types available
- Please specify which gripping surface you require – Serrated or Smooth
- Clamping tolerance of +/- 0.5mm
- Counter boring and special profile shapes are available upon request

### Dimensions (Metric)

Part No.	A	B	C
DC65	58	99.5	15°
DC65S	53	99.5	15°

### DC65 Round Collets

Nominal Gripping Diameter	Serrated Part Number	Smooth Part Number	Nominal Gripping Diameter	Serrated Part Number	Smooth Part Number	Nominal Gripping Diameter	Serrated Part Number	Smooth Part Number
4mm	-	DC65S-R04	25mm	DC65-R25	DC65S-R25	46mm	DC65-R46	DC65S-R46
5mm	-	DC65S-R05	26mm	DC65-R26	DC65S-R26	47mm	DC65-R47	DC65S-R47
6mm	-	DC65S-R06	27mm	DC65-R27	DC65S-R27	48mm	DC65-R48	DC65S-R48
7mm	-	DC65S-R07	28mm	DC65-R28	DC65S-R28	49mm	DC65-R49	DC65S-R49
8mm	DC65-R08*	DC65S-R08	29mm	DC65-R29	DC65S-R29	50mm	DC65-R50	DC65S-R50
9mm	DC65-R09*	DC65S-R09	30mm	DC65-R30	DC65S-R30	51mm	DC65-R51	DC65S-R51
10mm	DC65-R10*	DC65S-R10	31mm	DC65-R31	DC65S-R31	52mm	DC65-R52	DC65S-R52
11mm	DC65-R11	DC65S-R11	32mm	DC65-R32	DC65S-R32	53mm	DC65-R53	DC65S-R53
12mm	DC65-R12	DC65S-R12	33mm	DC65-R33	DC65S-R33	54mm	DC65-R54	DC65S-R54
13mm	DC65-R13	DC65S-R13	34mm	DC65-R34	DC65S-R34	55mm	DC65-R55	DC65S-R55
14mm	DC65-R14	DC65S-R14	35mm	DC65-R35	DC65S-R35	56mm	DC65-R56	DC65S-R56
15mm	DC65-R15	DC65S-R15	36mm	DC65-R36	DC65S-R36	57mm	DC65-R57	DC65S-R57
16mm	DC65-R16	DC65S-R16	37mm	DC65-R37	DC65S-R37	58mm	DC65-R58	DC65S-R58
17mm	DC65-R17	DC65S-R17	38mm	DC65-R38	DC65S-R38	59mm	DC65-R59	DC65S-R59
18mm	DC65-R18	DC65S-R18	39mm	DC65-R39	DC65S-R39	60mm	DC65-R60	DC65S-R60
19mm	DC65-R19	DC65S-R19	40mm	DC65-R40	DC65S-R40	61mm	DC65-R61	DC65S-R61
20mm	DC65-R20	DC65S-R20	41mm	DC65-R41	DC65S-R41	62mm	DC65-R62	DC65S-R62
21mm	DC65-R21	DC65S-R21	42mm	DC65-R42	DC65S-R42	63mm	DC65-R63	DC65S-R63
22mm	DC65-R22	DC65S-R22	43mm	DC65-R43	DC65S-R43	64mm	DC65-R64	DC65S-R64
23mm	DC65-R23	DC65S-R23	44mm	DC65-R44	DC65S-R44	65mm	DC65-R65	DC65S-R65
24mm	DC65-R24	DC65S-R24	45mm	DC65-R45	DC65S-R45			

\* Radial grooves only - larger sizes have axial and radial grooves

### DC65 Hexagon Collets

Available from 7mm to 56mm across flats sides of the hexagon in 1mm increments. Part number is **DC65-X\*\***. Please state which size you require, smooth (7-56mm) or serrated (8-56mm) gripping surface is available.

### DC65 Square Collets

Available from 8mm to 46mm across flats sides of the square in 1mm increments. Part number is **DC65-S\*\***. Please state which size you require, smooth (7-46mm) or serrated (8-46mm) gripping surface is available.

### DC65 Emergency Collets

Available only with 5mm, 10mm, 20mm or 40mm pilot holes. Part number is **DC65-E\*\***. Please state which size you require.



## DC Quick change collets to suit DHP80/DHF80/DRF80 Collet chucks

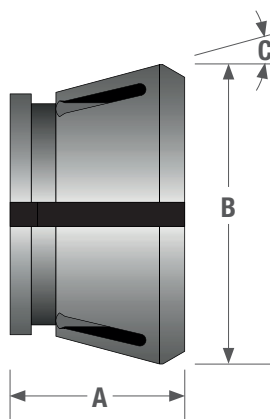
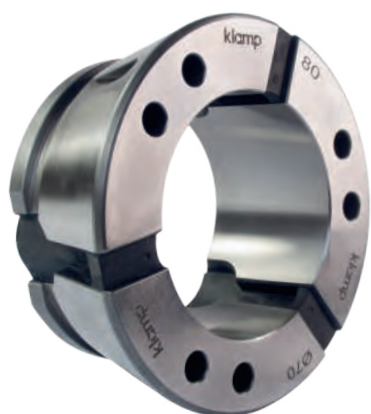

### DC80 Varibore Collets

- Round, Hexagon, Square or Emergency types available
- Please specify which gripping surface you require – Serrated or Smooth
- Clamping tolerance of +/- 0.5mm
- Counter boring and special profile shapes are available upon request

### Dimensions (Metric)

Part No.	A	B	C
DC80	53	114.5	15°

### DC80 Round Collets

Nominal Gripping Diameter	Serrated Part Number	Smooth Part Number
5mm	-	DC80S-R05
6mm	-	DC80S-R06
7mm	-	DC80S-R07
8mm	DC80-R08*	DC80S-R08
9mm	DC80-R09*	DC80S-R09
10mm	DC80-R10*	DC80S-R10
11mm	DC80-R11	DC80S-R11
12mm	DC80-R12	DC80S-R12
13mm	DC80-R13	DC80S-R13
14mm	DC80-R14	DC80S-R14
15mm	DC80-R15	DC80S-R15
16mm	DC80-R16	DC80S-R16
17mm	DC80-R17	DC80S-R17
18mm	DC80-R18	DC80S-R18
19mm	DC80-R19	DC80S-R19
20mm	DC80-R20	DC80S-R20
21mm	DC80-R21	DC80S-R21
22mm	DC80-R22	DC80S-R22
23mm	DC80-R23	DC80S-R23
24mm	DC80-R24	DC80S-R24
25mm	DC80-R25	DC80S-R25
26mm	DC80-R26	DC80S-R26
27mm	DC80-R27	DC80S-R27
28mm	DC80-R28	DC80S-R28
29mm	DC80-R29	DC80S-R29

Nominal Gripping Diameter	Serrated Part Number	Smooth Part Number
30mm	DC80-R30	DC80S-R30
31mm	DC80-R31	DC80S-R31
32mm	DC80-R32	DC80S-R32
33mm	DC80-R33	DC80S-R33
34mm	DC80-R34	DC80S-R34
35mm	DC80-R35	DC80S-R35
36mm	DC80-R36	DC80S-R36
37mm	DC80-R37	DC80S-R37
38mm	DC80-R38	DC80S-R38
39mm	DC80-R39	DC80S-R39
40mm	DC80-R40	DC80S-R40
41mm	DC80-R41	DC80S-R41
42mm	DC80-R42	DC80S-R42
43mm	DC80-R43	DC80S-R43
44mm	DC80-R44	DC80S-R44
45mm	DC80-R45	DC80S-R45
46mm	DC80-R46	DC80S-R46
47mm	DC80-R47	DC80S-R47
48mm	DC80-R48	DC80S-R48
49mm	DC80-R49	DC80S-R49
50mm	DC80-R50	DC80S-R50
51mm	DC80-R51	DC80S-R51
52mm	DC80-R52	DC80S-R52
53mm	DC80-R53	DC80S-R53
54mm	DC80-R54	DC80S-R54

Nominal Gripping Diameter	Serrated Part Number	Smooth Part Number
55mm	DC80-R55	DC80S-R55
56mm	DC80-R56	DC80S-R56
57mm	DC80-R57	DC80S-R57
58mm	DC80-R58	DC80S-R58
59mm	DC80-R59	DC80S-R59
60mm	DC80-R60	DC80S-R60
61mm	DC80-R61	DC80S-R61
62mm	DC80-R62	DC80S-R62
63mm	DC80-R63	DC80S-R63
64mm	DC80-R64	DC80S-R64
65mm	DC80-R65	DC80S-R65
66mm	DC80-R66	DC80S-R66
67mm	DC80-R67	DC80S-R67
68mm	DC80-R68	DC80S-R68
69mm	DC80-R69	DC80S-R69
70mm	DC80-R70	DC80S-R70
71mm	DC80-R71	DC80S-R71
72mm	DC80-R72	DC80S-R72
73mm	DC80-R73	DC80S-R73
74mm	DC80-R74	DC80S-R74
75mm	DC80-R75	DC80S-R75
76mm	DC80-R76	DC80S-R76
77mm	DC80-R77	DC80S-R77
78mm	DC80-R78	DC80S-R78
79mm	DC80-R79	DC80S-R79
80mm	DC80-R80	DC80S-R80

\* Radial grooves only - larger sizes have axial and radial grooves

### DC80 Hexagon Collets

Available from 7mm to 68mm across flats sides of the hexagon in 1mm increments. Part number is **DC80-X\*\***. Please state which size you require, smooth (7-68mm) or serrated (8-68mm) gripping surface is available.

### DC80 Square Collets

Available from 7mm to 56mm across flats sides of the square in 1mm increments. Part number is **DC80-S\*\***. Please state which size you require, smooth (7-56mm) or serrated (8-56mm) gripping surface is available.

### DC80 Emergency Collets

Available only with 8mm, 20mm or 40mm or 60mm pilot holes. Part number is **DC80-E\*\***. Please state which size you require.

## DC Quick Change Collets

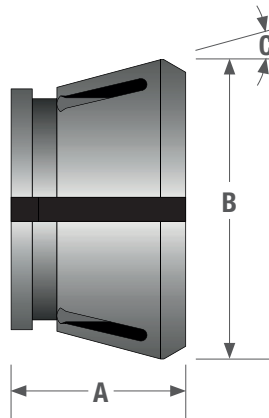
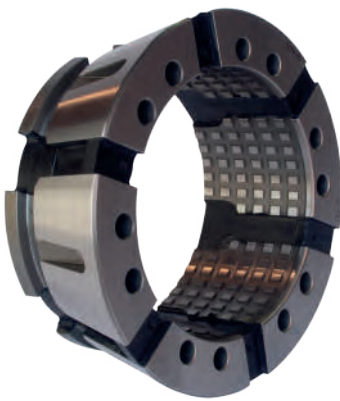

### DC100 Vari bore Collets

- Round, Hexagon, Square or Emergency types available
- Please specify which gripping surface you require – Serrated or Smooth
- Clamping tolerance of +/- 0.5mm
- Counter boring and special profile shapes are available upon request

### Dimensions (Metric)

Part No.	A	B	C
DC100	59	144.5	15°

### DC100 Round Collets

Nominal Gripping Diameter	Serrated Part Number	Smooth Part Number
16mm	DC100-R16	DC100S-R16
17mm	DC100-R17	DC100S-R17
18mm	DC100-R18	DC100S-R18
19mm	DC100-R19	DC100S-R19
20mm	DC100-R20	DC100S-R20
21mm	DC100-R21	DC100S-R21
22mm	DC100-R22	DC100S-R22
23mm	DC100-R23	DC100S-R23
24mm	DC100-R24	DC100S-R24
25mm	DC100-R25	DC100S-R25
26mm	DC100-R26	DC100S-R26
27mm	DC100-R27	DC100S-R27
28mm	DC100-R28	DC100S-R28
29mm	DC100-R29	DC100S-R29
30mm	DC100-R30	DC100S-R30
31mm	DC100-R31	DC100S-R31
32mm	DC100-R32	DC100S-R32
33mm	DC100-R33	DC100S-R33
34mm	DC100-R34	DC100S-R34
35mm	DC100-R35	DC100S-R35
36mm	DC100-R36	DC100S-R36
37mm	DC100-R37	DC100S-R37
38mm	DC100-R38	DC100S-R38
39mm	DC100-R39	DC100S-R39
40mm	DC100-R40	DC100S-R40
41mm	DC100-R41	DC100S-R41
42mm	DC100-R42	DC100S-R42
43mm	DC100-R43	DC100S-R43
44mm	DC100-R44	DC100S-R44

Nominal Gripping Diameter	Serrated Part Number	Smooth Part Number
45mm	DC100-R45	DC100S-R45
46mm	DC100-R46	DC100S-R46
47mm	DC100-R47	DC100S-R47
48mm	DC100-R48	DC100S-R48
49mm	DC100-R49	DC100S-R49
50mm	DC100-R50	DC100S-R50
51mm	DC100-R51	DC100S-R51
52mm	DC100-R52	DC100S-R52
53mm	DC100-R53	DC100S-R53
54mm	DC100-R54	DC100S-R54
55mm	DC100-R55	DC100S-R55
56mm	DC100-R56	DC100S-R56
57mm	DC100-R57	DC100S-R57
58mm	DC100-R58	DC100S-R58
59mm	DC100-R59	DC100S-R59
60mm	DC100-R60	DC100S-R60
61mm	DC100-R61	DC100S-R61
62mm	DC100-R62	DC100S-R62
63mm	DC100-R63	DC100S-R63
64mm	DC100-R64	DC100S-R64
65mm	DC100-R65	DC100S-R65
66mm	DC100-R66	DC100S-R66
67mm	DC100-R67	DC100S-R67
68mm	DC100-R68	DC100S-R68
69mm	DC100-R69	DC100S-R69
70mm	DC100-R70	DC100S-R70
71mm	DC100-R71	DC100S-R71
72mm	DC100-R72	DC100S-R72
73mm	DC100-R73	DC100S-R73

Nominal Gripping Diameter	Serrated Part Number	Smooth Part Number
74mm	DC100-R74	DC100S-R74
75mm	DC100-R75	DC100S-R75
76mm	DC100-R76	DC100S-R76
77mm	DC100-R77	DC100S-R77
78mm	DC100-R78	DC100S-R78
79mm	DC100-R79	DC100S-R79
80mm	DC100-R80	DC100S-R80
81mm	DC100-R81	DC100S-R81
82mm	DC100-R82	DC100S-R82
83mm	DC100-R83	DC100S-R83
84mm	DC100-R84	DC100S-R84
85mm	DC100-R85	DC100S-R85
86mm	DC100-R86	DC100S-R86
87mm	DC100-R87	DC100S-R87
88mm	DC100-R88	DC100S-R88
89mm	DC100-R89	DC100S-R89
90mm	DC100-R90	DC100S-R90
91mm	DC100-R91	DC100S-R91
92mm	DC100-R92	DC100S-R92
93mm	DC100-R93	DC100S-R93
94mm	DC100-R94	DC100S-R94
95mm	DC100-R95	DC100S-R95
96mm	DC100-R96	DC100S-R96
97mm	DC100-R97	DC100S-R97
98mm	DC100-R98	DC100S-R98
99mm	DC100-R99	DC100S-R99
100mm	DC100-R100	DC100S-R100

### DC100 Hexagon Collets

Available from 50mm to 86mm across flats sides of the hexagon in 1mm increments. Part number is **DC100-X\*\***. Please state which size you require, smooth or serrated gripping surface is available.

### DC100 Square Collets

Available from 50mm to 70mm across flats sides of the square in 1mm increments. Part number is **DC100-S\*\***. Please state which size you require, smooth or serrated gripping surface is available.

### DC100 Emergency Collets

Available only with 30mm, 45mm, 65mm or 90mm pilot holes. Part number is **DC100-E\*\***. Please state which size you require.

## D Series Standard Accessories

### Work Stops

- Stops can be provided to allow for accurate z-axis positioning of short workpieces within the collet chuck.
- A threaded stud is provided for easy adjustment to suit your work piece
- All stops are easily installed from the front face utilising a side bolt to hold the stop securely in place.
- These stops can be installed on all DHP & DKF series collet chucks.
- Full length spindle stops can also be provided for long work pieces, these can utilise the entire length of your machine spindle, please contact your Klamp supplier to see the maximum length stop your machine could accommodate.

Work Stop on a DKF Collet Chuck

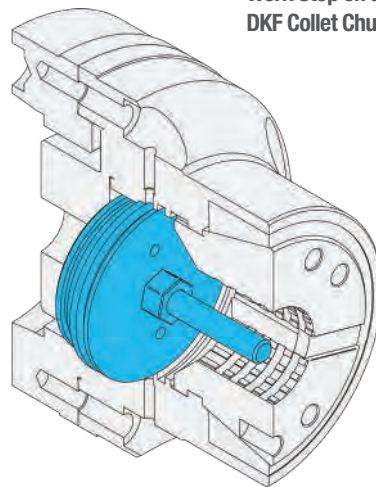

Additional Length Work Stop on a DKF Collet Chuck

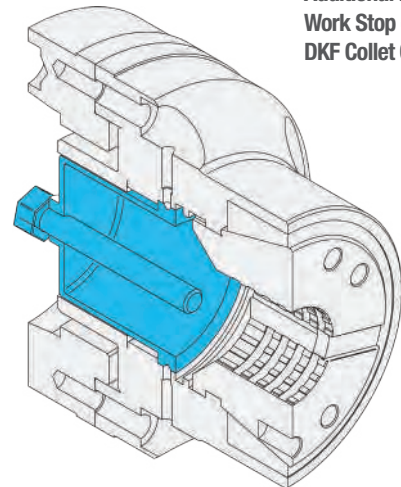

### Spring Ejectors DKF Series Only

- Standard spring ejectors for in the DKF series are use for second-spindle operations to expel finished workpiece into the parts catcher.
- All spring ejectors are easily installed from the front face utilising a supplied key
- Many variants of spring ejector are available to suit your production process.
- Full length hydraulic or pneumatic ejectors can also be provided for long work pieces, this can utilise the entire length of your machine spindle, please contact your Klamp supplier to see the maximum length stop your machine could accommodate.

Spring Ejector on a DKF Collet Chuck

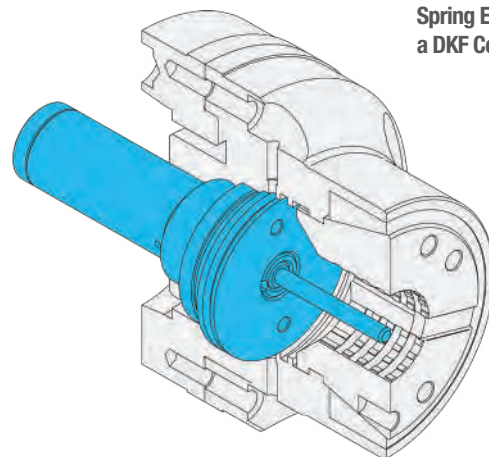

### Collet Changing Device D Series Collet Chucks

- Easy to use device to allow DC Collets to be removed or installed.
- Simply insert the steel pins into the Collet face holes and squeeze the trigger to collapse the DC Collet.
- Availabel in both manual and pneumatic versions.

Part Number	To Suit		Type
	DHP Series	DKF Series	
DCD42	DHP42	DKF42	Manual
DCD52	DHP52	DKF52	Manual
DCD65	DHP65	DKF65	Manual
DCD80	DHP80	DKF80	Pneumatic
DCD100	-	DKF100	Pneumatic





# Collet Chucks

## Low-profile



## 5C & 16C Pull Back Power Collet Chucks



### Pull Back Action

The gripping pull-back action to actuate the collet chuck means the work piece will be moved slightly in the Z-Axis. This is normally acceptable for first operation work and the work piece position can easily be determined with a facing cut.

### Problem Free Installation

Klamp collet chucks are provided with mounting bolts and a custom machined drawtube connector allowing you to start using the Klamp collet chuck straight out of the box.

### Quick & Easy Mounting

Klamp collet chucks mount directly to the lathe spindle or use a precision adaptor plate to ensure a consistent mounting without the need for correction. The precision fit of the Klamp collet chuck enhances the rigidity of the overall system. The need for adjustment is minimal, meaning less machine down-time.

### Long Service Life

All Klamp collet chucks are case hardened and ground optimising the rigidity, strength and durability.

### High Speed

Direct mount design ensures high concentricity that is suitable for higher speed operations that are not appropriate for conventional 3-jaw chuck due to the negative effects of centrifugal force.

### Low Profile

Small nose diameter to provide excellent tool clearance.

### Suitable for 5C/16C Collet Types



## 5C & 16C Pull Back Power Collet Chucks

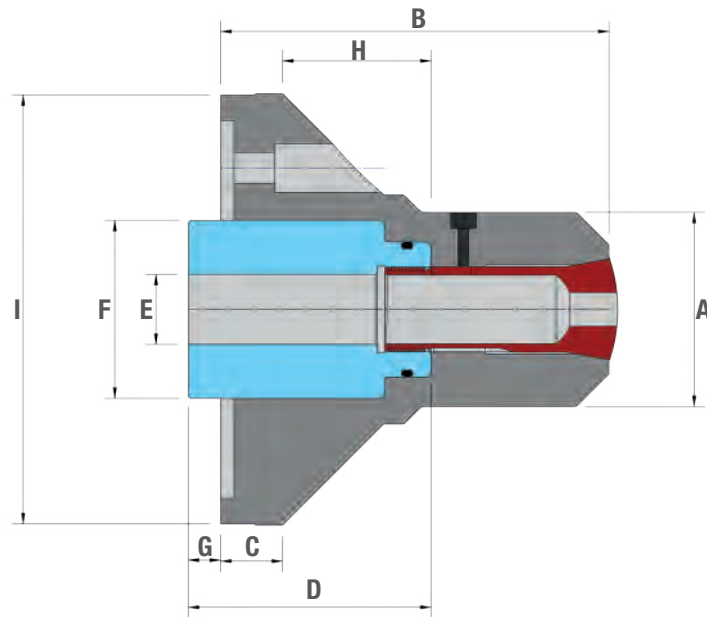

KLAMP Type	DEL5C			DEL16C		
Mounting	Z140	A5	A6	Z170	A5	A6
Part Number	DEL5C-Z140	DEL5C-A5	DEL5C-A6	DEL16C-Z170	DEL16C-A5	DEL16C-A6
Spring Collet Type	5C			16C		
Spring Collet Gripping Range *	Minimum	1			2	
	Maximum	27			42	
Spring collet increments	0.5			0.5		
A	72			85		
B	139	141		157	152	160
C	23	18	19	18.5	18	19
D	90	98		84.5	92.5	
E	M60 x 2.0		M75 x 2.0	M60 x 2.0		M75 x 2.0
F	66		83	66		83
G Maximum	32	18		18	10	18
G Minimum	31	17		17	9	17
H	55		62	54.5	49.5	56.5
I	159	135	170	190	135	170
Pull Back Ratio	1:3			1:3		
Max. input force	kN			24		
Max. Speed	min <sup>-1</sup>			6000		
Net Weight	kg			11		
Matching Kitagawa Cylinders	S1246 SS1246 SR1146			S1246 SS1246 SR1146		

## 5C & 16C Collet Chuck Collet Options



### 5C Collets – Type 0123 16C Collets – Type G119

- Round, Hexagon or Square types available
- Smooth gripping surface only
- 0.5mm sizes available upon request

#### Dimensions (Metric)

Part No.	A	B	C	D
5C	31.75	83.40	37.30	10°
16C	48	110.50	57.50	10°

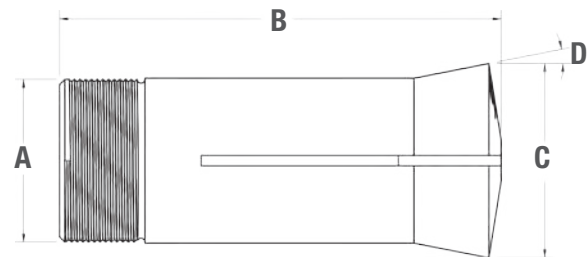

Gripping Diameter	5C - Type 0123 for DEL 5C			16C - Type G119 for DEL 16C		
	Round	Hexagon	Square	Round	Hexagon	Square
1mm	5C-R01	-	-	-	-	-
2mm	5C-R02	-	-	16C-R02	-	-
3mm	5C-R03	-	-	16C-R03	-	-
4mm	5C-R04	-	-	16C-R04	-	-
5mm	5C-R05	5C-X05	5C-S05	16C-R05	16C-X05	16C-S05
6mm	5C-R06	-	5C-S06	16C-R06	-	16C-S06
7mm	5C-R07	5C-X07	5C-S07	16C-R07	16C-X07	16C-S07
8mm	5C-R08	5C-X08	5C-S08	16C-R08	16C-X08	16C-S08
9mm	5C-R09	-	-	16C-R09	-	-
10mm	5C-R10	5C-X10	5C-S10	16C-R10	16C-X10	16C-S10
11mm	5C-R11	-	-	16C-R11	16C-X11	-
12mm	5C-R12	5C-X12	5C-S12	16C-R12	16C-X12	16C-S12
13mm	5C-R13	-	-	16C-R13	16C-X13	-
14mm	5C-R14	5C-X14	5C-S14	16C-R14	16C-X14	16C-S14
15mm	5C-R15	-	-	16C-R15	16C-X15	16C-S15
16mm	5C-R16	5C-X16	5C-S16	16C-R16	16C-X16	16C-S16
17mm	5C-R17	-	-	16C-R17	16C-X17	-
18mm	5C-R18	5C-X18	5C-S18	16C-R18	16C-X18	16C-S18
19mm	5C-R19	-	-	16C-R19	16C-X19	-
20mm	5C-R20	5C-X20	-	16C-R20	16C-X20	16C-S20
21mm	5C-R21	-	-	16C-R21	-	-

Gripping Diameter	5C - Type 0123 for DEL 5C			16C - Type G119 for DEL 16C		
	Round	Hexagon	Square	Round	Hexagon	Square
22mm	5C-R22	5C-X22	-	16C-R22	16C-X22	16C-S22
23mm	5C-R23	-	-	16C-R23	-	-
24mm	5C-R24	-	-	16C-R24	16C-X24	-
25mm	5C-R25	-	-	16C-R25	16C-X25	16C-S25
26mm	5C-R26	-	-	16C-R26	16C-X26	-
27mm	5C-R27	-	-	16C-R27	16C-X27	-
28mm	-	-	-	16C-R28	-	-
29mm	-	-	-	16C-R29	-	-
30mm	-	-	-	16C-R30	16C-X30	-
31mm	-	-	-	16C-R31	-	-
32mm	-	-	-	16C-R32	16C-X32	-
33mm	-	-	-	16C-R33	-	-
34mm	-	-	-	16C-R34	-	-
35mm	-	-	-	16C-R35	16C-X35	-
36mm	-	-	-	16C-R36	-	-
37mm	-	-	-	16C-R37	-	-
38mm	-	-	-	16C-R38	-	-
39mm	-	-	-	16C-R39	-	-
40mm	-	-	-	16C-R40	-	-
41mm	-	-	-	16C-R41	-	-
42mm	-	-	-	16C-R42	-	-

Emergency Collet with soft face and pilot hole 3mm diameter is available both for the 5C and 16C Type – Part No. **5C-EMERGENCY / 16C-EMERGENCY**





am





# Expanding Mandrels

## KEM Series

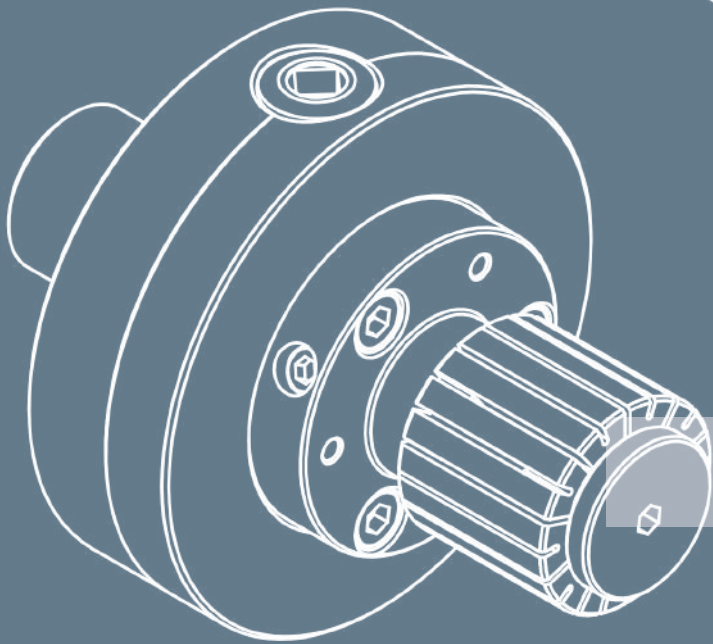
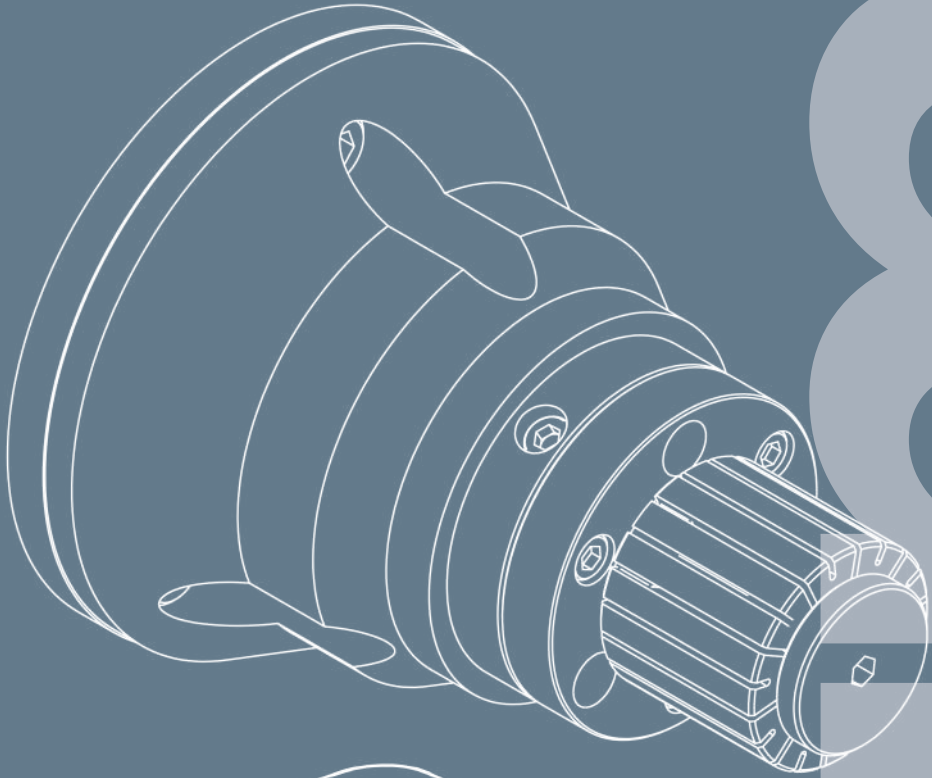

## Power Expanding Mandrels for Lathes

### Rigid and Accurate Workholding for Internal Diameters

#### Internal Clamping Offers Full Part Access

Allows for full access to the entire external profile of the workpiece so all external diameters can be turned in a single operation, guaranteeing perfect concentricity.

#### Quick & Easy Mounting

Klamp expanding mandrels mount directly to the lathe spindle or use a precision adaptor plate to ensure a consistent mounting without the need for correction. The precision fit of the Klamp collet chuck enhances the rigidity of the overall system. The need for adjustment is minimal, meaning less machine down-time.

#### High Accuracy & Rigidity

Pull-back design draws the workpiece securely against a part locator for 'dual-contact' rigidity.

#### Modular Design

All Mandrel models have a common flange configuration, enabling full interchangeability with all back bodies.

#### Parallel Expansion for Optimum Accuracy and Grip Force

The Klamp double-angle design provides parallel sleeve expansion, ensuring full-length part contact and positive release when the part is unclamped.



### Two Regular Sleeve Types Available



#### Standard Sleeves

Cost effective sleeves where the expander pin is outside the sleeve body, with either a 0.5mm or 0.8 gripping range (see pages 51-53 for more detail), suitable for through bores and operated with a part locator.



#### Flush sleeves

Expander pin is inside/level with the sleeve body with either a 0.5mm or 0.8 gripping range (see pages 51-53 for more detail), suitable for blind bores and enables the sleeve to grip as much of the internal diameter as possible.

### Customised Systems Available



Dual sleeves (as shown above), extended length sleeves, 1/2 length sleeves and larger diameter sizes are on the market with up to 635mm ID gripping for supporting a wide range of parts.



A KEM dual sleeve system mounted on a rotary table. Actuated via a hydraulic cylinder and supported via a special hydraulic tailstock this setup is perfect for automated machining cells allowing multiple parts to be robot loaded and machined at the same time.

Power Expanding Mandrels for Lathes

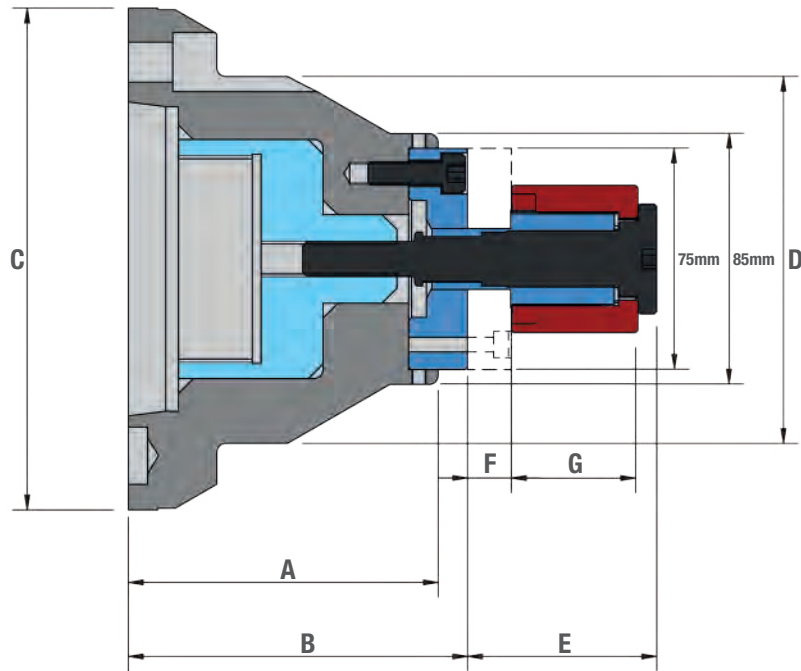

Mandrel Assembly Type	Spindle Mounting	Part Number	Suitable Sleeve Types	Sleeve Gripping Range*		Sleeve Increments	A	B	C	D	E	F	G Standard (G Flush)	Maximum Drawnut Thread Size	Maximum Pull Force kN	Maximum Gripping Force kN
				Min	Max											
KEM-AS	Z140	KEM-AS-14	Standard or Flush	12.4	22.4	0.5	83	103	160	100	39.9	14.5	22.1 (25.4)	M60 x 1.5	7	12.5
	A5	KEM-AS-A5					88	108	135	100				M60 x 1.5		
	A6	KEM-AS-A6					95	115	170	125				M75 x 1.5		
	A8	KEM-AS-A8					100	120	210	125				M90 x 2.0		
KEM-BS	Z140	KEM-BS-14	Standard or Flush	15.9	29.1	0.5	83	103	160	100	46	15	27.0 (31.0)	M60 x 1.5	10	17.8
	A5	KEM-BS-A5					88	108	135	100				M60 x 1.5		
	A6	KEM-BS-A6					95	115	170	125				M75 x 1.5		
	A8	KEM-BS-A8					100	120	210	125				M90 x 2.0		
KEM-CS	Z140	KEM-CS-14	Standard or Flush	21.9	40.3	0.8	83	103	160	100	52.1	15.5	32.0 (36.6)	M60 x 1.5	12	21.4
	A5	KEM-CS-A5					88	108	135	100				M60 x 1.5		
	A6	KEM-CS-A6					95	115	170	125				M75 x 1.5		
	A8	KEM-CS-A8					100	120	210	125				M90 x 2.0		
KEM-DS	Z140	KEM-DS-14	Standard or Flush	28.3	51.5	0.8	83	103	160	100	59	15.2	38.1 (43.8)	M60 x 1.5	18	32
	A5	KEM-DS-A5					88	108	135	100				M60 x 1.5		
	A6	KEM-DS-A6					95	115	170	125				M75 x 1.5		
	A8	KEM-DS-A8					100	120	210	125				M90 x 2.0		
KEM-ES	Z140	KEM-ES-14	Standard or Flush	41.1	82.7	0.8	83	103	160	100	64	14.7	43.0 (49.3)	M60 x 1.5	23	40.9
	A5	KEM-ES-A5					88	108	135	100				M60 x 1.5		
	A6	KEM-ES-A6					95	115	170	125				M75 x 1.5		
	A8	KEM-ES-A8					100	120	210	125				M90 x 2.0		

## Manually Actuated Expanding Mandrels

### Heavy Duty Gearing

The Klamp manually actuated mandrel (KEM-MA) provides a high gripping force utilising the same standard Klamp Mandrel assemblies as the power operated systems therefore giving you the ability to have an internal gripping solution that can be rapidly deployed with whatever standard workholding system your machine(s) has.

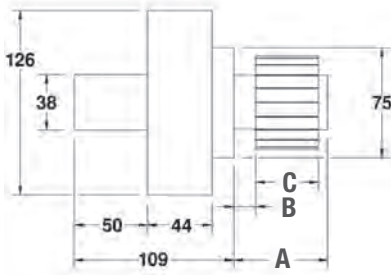

### Two Regular Sleeve Types Available

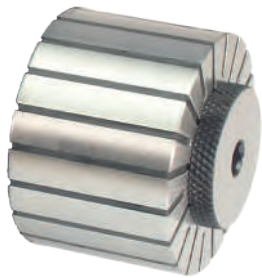

#### Standard Sleeves

Cost effective sleeves where the expander pin is outside the sleeve body, with either a 0.5mm or 0.8 gripping range (see pages 51-53 for more detail), suitable for through bores and operated with a part locator.



#### Flush Sleeves

Expander pin is inside/level with the sleeve body with either a 0.5mm or 0.8 gripping range (see pages 51-53 for more detail), suitable for blind bores and enables the sleeve to grip as much of the internal diameter as possible.

Mandrel Assembly Type	Mounting	Part Number	Suitable Sleeve Type	Sleeve Gripping Range*		Sleeve Increments	A	B	C Standard (C Flush)
				Min	Max				
KEM-AS	Manual Actuator	KEM-AS-MA	Standard or Flush	12.4	22.4	0.5	39.9	14.5	22.1 (25.4)
KEM-BS	Manual Actuator	KEM-BS-MA		15.9	29.1	0.5	46	15	27.0 (31.0)
KEM-CS	Manual Actuator	KEM-CS-MA		21.9	40.3	0.8	52.1	15.5	32.0 (36.6)
KEM-DS	Manual Actuator	KEM-DS-MA		28.3	51.5	0.8	59	15.2	38.1 (43.8)
KEM-ES	Manual Actuator	KEM-ES-MA		41.1	82.7	0.8	64	14.7	43.0 (49.3)



Load the KEM-MA manual actuator into a three jaw or collet chuck, gripping on the 38mm location spigot.

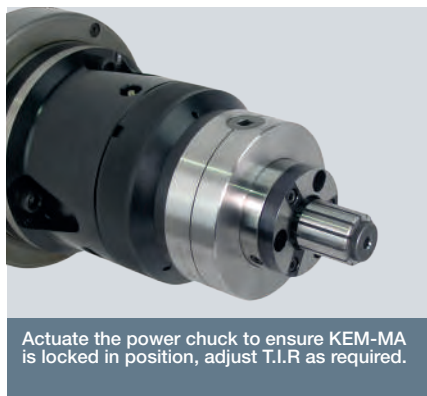

Actuate the power chuck to ensure KEM-MA is locked in position, adjust T.I.R as required.



Load a workpiece's internal diameter over the sleeve and actuate the mandrel using the key provided.

## Sleeve Options for all KEM Series

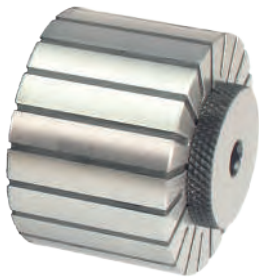

### KEM-AS

Standard Sleeve		
Nominal Sleeve Ø	Gripping Range mm	Part Number
12.50	12.40 - 12.90	92.000.210.1250
13.00	12.90 - 13.40	92.000.210.1300
13.50	13.40 - 13.90	92.000.210.1350
14.00	13.90 - 14.40	92.000.210.1400
14.50	14.40 - 14.90	92.000.210.1450
15.00	14.90 - 15.40	92.000.210.1500
15.50	15.40 - 15.90	92.000.210.1550
16.00	15.90 - 16.40	92.000.210.1600

Flush Sleeve		
Nominal Sleeve Ø	Gripping Range mm	Part Number
16.50	16.40 - 16.90	92.001.210.1650
17.00	16.90 - 17.40	92.001.210.1700
17.50	17.40 - 17.90	92.001.210.1750
18.00	17.90 - 18.40	92.001.210.1800
18.50	18.40 - 18.90	92.001.210.1850
19.00	18.90 - 19.40	92.001.210.1900
19.50	19.40 - 19.90	92.001.210.1950
20.00	19.90 - 20.40	92.001.210.2000
20.50	20.40 - 20.90	92.001.210.2050
21.00	20.90 - 21.40	92.001.210.2100
21.50	21.40 - 21.90	92.001.210.2150
22.00	21.90 - 22.40	92.001.210.2200

### KEM-BS

Standard Sleeve		
Nominal Sleeve Ø	Gripping Range mm	Part Number
16.00	15.90 - 16.40	92.050.210.1600
16.50	16.40 - 16.90	92.050.210.1650
17.00	16.90 - 17.40	92.050.210.1700
17.50	17.40 - 17.90	92.050.210.1750
18.00	17.90 - 18.40	92.050.210.1800
18.50	18.40 - 18.90	92.050.210.1850
19.00	18.90 - 19.40	92.050.210.1900
19.50	19.40 - 19.90	92.050.210.1950
20.00	19.90 - 20.40	92.050.210.2000
20.50	20.40 - 20.90	92.050.210.2050
21.00	20.90 - 21.40	92.050.210.2100
21.50	21.40 - 21.90	92.050.210.2150
22.00	21.90 - 22.40	92.050.210.2200

Flush Sleeve		
Nominal Sleeve Ø	Gripping Range mm	Part Number
22.00	21.90 - 22.70	92.051.210.2200
22.80	22.70 - 23.50	92.051.210.2280
23.60	23.50 - 24.30	92.051.210.2360
24.40	24.30 - 25.10	92.051.210.2440
25.20	25.10 - 25.90	92.051.210.2520
26.00	25.90 - 26.70	92.051.210.2600
26.80	26.70 - 27.50	92.051.210.2680
27.60	27.50 - 28.30	92.051.210.2760
28.40	28.30 - 29.10	92.051.210.2840

## Sleeve Options for all KEM Series

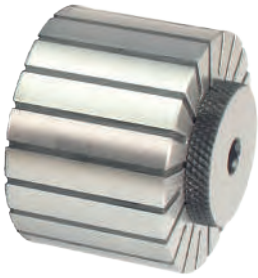

### KEM-CS

Standard Sleeve		
Nominal Sleeve Ø	Gripping Range mm	Part Number
22.00	21.90 - 22.70	92.100.210.2200
22.80	22.70 - 23.50	92.100.210.2280
23.60	23.50 - 24.30	92.100.210.2360
24.40	24.30 - 25.10	92.100.210.2440
25.20	25.10 - 25.90	92.100.210.2520
26.00	25.90 - 26.70	92.100.210.2600
26.80	26.70 - 27.50	92.100.210.2680
27.60	27.50 - 28.30	92.100.210.2760
28.40	28.30 - 29.10	92.100.210.2840

Flush Sleeve		
Nominal Sleeve Ø	Gripping Range mm	Part Number
28.40	28.30 - 29.10	92.101.210.2840
29.20	29.10 - 29.90	92.101.210.2920
30.00	29.90 - 30.70	92.101.210.3000
30.80	30.70 - 31.50	92.101.210.3080
31.60	31.50 - 32.30	92.101.210.3160
32.40	32.30 - 33.10	92.101.210.3240
33.20	33.10 - 33.90	92.101.210.3320
34.00	33.90 - 34.70	92.101.210.3400
34.80	34.70 - 35.50	92.101.210.3480
35.60	35.50 - 36.30	92.101.210.3560
36.40	36.30 - 37.10	92.101.210.3640
37.20	37.10 - 37.90	92.101.210.3720
38.00	37.90 - 38.70	92.101.210.3800
38.80	38.70 - 39.50	92.101.210.3880
39.60	39.50 - 40.30	92.101.210.3960

### KEM-DS

Standard Sleeve		
Nominal Sleeve Ø	Gripping Range mm	Part Number
28.40	28.30 - 29.10	92.150.210.2840
29.20	29.10 - 29.90	92.150.210.2920
30.00	29.90 - 30.70	92.150.210.3000
30.80	30.70 - 31.50	92.150.210.3080
31.60	31.50 - 32.30	92.150.210.3160
32.40	32.30 - 33.10	92.150.210.3240
33.20	33.10 - 33.90	92.150.210.3320
34.00	33.90 - 34.70	92.150.210.3400
34.80	34.70 - 35.50	92.150.210.3480
35.60	35.50 - 36.30	92.150.210.3560
36.40	36.30 - 37.10	92.150.210.3640
37.20	37.10 - 37.90	92.150.210.3720
38.00	37.90 - 38.70	92.150.210.3800
38.80	38.70 - 39.50	92.150.210.3880
39.60	39.50 - 40.30	92.150.210.3960
40.40	40.30 - 41.10	92.150.210.4040
41.20	41.10 - 41.90	92.150.210.4120

Flush Sleeve		
Nominal Sleeve Ø	Gripping Range mm	Part Number
39.60	39.50 - 40.30	92.151.210.3960
40.40	40.30 - 41.10	92.151.210.4040
41.20	41.10 - 41.90	92.151.210.4120
42.00	41.90 - 42.70	92.151.210.4200
42.80	42.70 - 43.50	92.151.210.4280
43.60	43.50 - 44.30	92.151.210.4360
44.40	44.30 - 45.10	92.151.210.4440
45.20	45.10 - 45.90	92.151.210.4520
46.00	45.90 - 46.70	92.151.210.4600
46.80	46.70 - 47.50	92.151.210.4680
47.60	47.50 - 48.30	92.151.210.4760
48.40	48.30 - 49.10	92.151.210.4840
49.20	49.10 - 49.90	92.151.210.4920
50.00	49.90 - 50.70	92.151.210.5000
50.80	50.70 - 51.50	92.151.210.5080



## Sleeve Options for all KEM Series



### KEM-ES

Standard Sleeve		
Nominal Sleeve Ø	Gripping Range mm	Part Number
41.20	41.10 - 41.90	92.200.210.4120
42.00	41.90 - 42.70	92.200.210.4200
42.80	42.70 - 43.50	92.200.210.4280
43.60	43.50 - 44.30	92.200.210.4360
44.40	44.30 - 45.10	92.200.210.4440
45.20	45.10 - 45.90	92.200.210.4520
46.00	45.90 - 46.70	92.200.210.4600
46.80	46.70 - 47.50	92.200.210.4680
47.60	47.50 - 48.30	92.200.210.4760
48.40	48.30 - 49.10	92.200.210.4840
49.20	49.10 - 49.90	92.200.210.4920
50.00	49.90 - 50.70	92.200.210.5000
50.80	50.70 - 51.50	92.200.210.5080
51.60	51.50 - 52.30	92.200.210.5160
52.40	52.30 - 53.10	92.200.210.5240
53.20	53.10 - 53.90	92.200.210.5320
54.00	53.90 - 54.70	92.200.210.5400
54.80	54.70 - 55.50	92.200.210.5480
55.60	55.50 - 56.30	92.200.210.5560
56.40	56.30 - 57.10	92.200.210.5640
57.20	57.10 - 57.90	92.200.210.5720
58.00	57.90 - 58.70	92.200.210.5800
58.80	58.70 - 59.50	92.200.210.5880
59.60	59.50 - 60.30	92.200.210.5960
60.40	60.30 - 61.10	92.200.210.6040
61.20	61.10 - 61.90	92.200.210.6120
62.00	61.90 - 62.70	92.200.210.6200
62.80	62.70 - 63.50	92.200.210.6280

Flush Sleeve		
Nominal Sleeve Ø	Gripping Range mm	Part Number
50.80	50.70 - 51.50	92.201.210.5080
51.60	51.50 - 52.30	92.201.210.5160
52.40	52.30 - 53.10	92.201.210.5240
53.20	53.10 - 53.90	92.201.210.5320
54.00	53.90 - 54.70	92.201.210.5400
54.80	54.70 - 55.50	92.201.210.5480
55.60	55.50 - 56.30	92.201.210.5560
56.40	56.30 - 57.10	92.201.210.5640
57.20	57.10 - 57.90	92.201.210.5720
58.00	57.90 - 58.70	92.201.210.5800
58.80	58.70 - 59.50	92.201.210.5880
59.60	59.50 - 60.30	92.201.210.5960
60.40	60.30 - 61.10	92.201.210.6040
61.20	61.10 - 61.90	92.201.210.6120
62.00	61.90 - 62.70	92.201.210.6200
62.80	62.70 - 63.50	92.201.210.6280
63.60	63.50 - 64.30	92.201.210.6360
64.40	64.30 - 65.10	92.201.210.6440
65.20	65.10 - 65.90	92.201.210.6520
66.00	65.90 - 66.70	92.201.210.6600
66.80	66.70 - 67.50	92.201.210.6680
67.60	67.50 - 68.30	92.201.210.6760
68.40	68.30 - 69.10	92.201.210.6840
69.20	69.10 - 69.90	92.201.210.6920
70.00	69.90 - 70.70	92.201.210.7000
70.80	70.70 - 71.50	92.201.210.7080
71.60	71.50 - 72.30	92.201.210.7160
72.40	72.30 - 73.10	92.201.210.7240
73.20	73.10 - 73.90	92.201.210.7320
74.00	73.90 - 74.70	92.201.210.7400
74.80	74.70 - 75.50	92.201.210.7480
75.60	75.50 - 76.30	92.201.210.7560
76.40	76.30 - 77.10	92.201.210.7640
77.20	77.10 - 77.90	92.201.210.7720
78.00	77.90 - 78.70	92.201.210.7800
78.80	78.70 - 79.50	92.201.210.7880
79.60	79.50 - 80.30	92.201.210.7960
80.40	80.30 - 81.10	92.201.210.8040
81.20	81.10 - 81.90	92.201.210.8120
82.00	81.90 - 82.70	92.201.210.8200

## Data required to manufacture drawtube actuator

### Check which model is required

Fig. 1

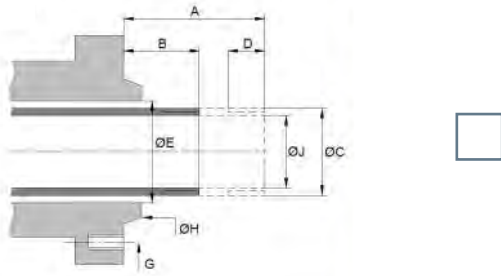



Fig. 2

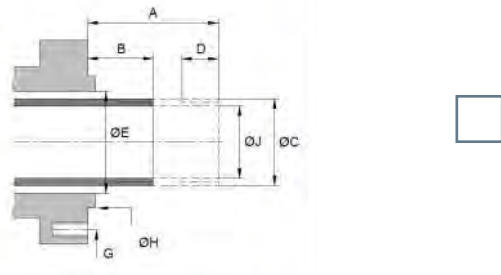



Fig. 3

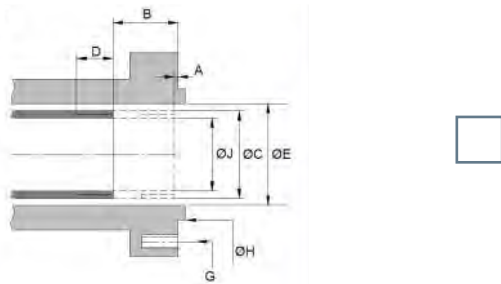
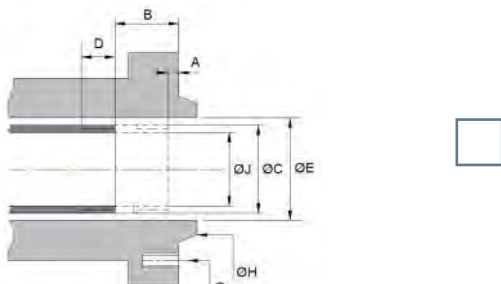



Fig. 4



A) Forward position of (drawtube from spindle face)

\_\_\_\_\_

B) Backward position of (drawtube from spindle face)

\_\_\_\_\_

C) Thread diameter form and pitch

State if RH or LH and external or internal

\_\_\_\_\_

D) Operative length of full thread

\_\_\_\_\_

E) Spindle bore diameter

State if taper

\_\_\_\_\_

G) Fixing details. Thread size =

PCD = \_\_\_\_\_ QTY = \_\_\_\_\_

Spacing = \_\_\_\_\_

J) Drawtube internal diameter

\_\_\_\_\_

American spindle mount

State type

\_\_\_\_\_

Straight spindle mount

State diameter

\_\_\_\_\_

### Drawtube Connector / Machine Spindle Information

Machine Make:

Model:

Year:

Chuck Make:

Model:

Serial Number:

Cylinder Make:

Model:

Serial Number:

Contact Name:	Position:
Company Name:	
Address:	
Postal Code/ZIP:	Country:
Telephone:	Fax:
Email:	Website:



am



## EUROPE

### KITAGAWA EUROPE LTD. (UK)

t +44 1725 514 010 f +44 1725 514 001  
e export@kitagawaeurope.com

### KITAGAWA EUROPE GmbH (Germany)

t +49 210 212 37800 f +49 210 212 37869  
e info@kitagawaeurope.de

### KITAGAWA EUROPE (Czech Republic)

t +420 603 856 122  
e michal.prokes@kitagawaeurope.de

### KITAGAWA EUROPE (Hungary)

t +36 30 510 3550  
e gabor.molnar@kitagawaeurope.de

### KITAGAWA EUROPE (Poland)

t +48 32 749 59 18  
e Lukasz.tomanek@kitagawaeurope.de

### KITAGAWA EUROPE (Romania)

t +40 727 770 329  
e roxana.tureac@kitagawaeurope.de

### KITAGAWA EUROPE (Slovenia/Croatia)

t +385 99 216 1940  
e juraij.perisic@kitagawaeurope.de

## AMERICA

### KITAGAWA – NORTHTECH INC.

t +1 847 310 8787 f +1 847 310 9484

## ASIA

### KITAGAWA PVT LTD. (India)

t +91 80 2976 5200 f +91 80 2976 5205  
e sales@kitagawaindia.com

### KITAGAWA IRON WORKS CO., LTD. (Japan)

t +81 847 40 0526 f +81 847 450 8911

### KITAGAWA IRON WORKS CO., LTD. (China)

t +86 21 6295 5772 f +86 21 6295 5792

### KITAGAWA CO., LTD. (Thailand)

t +66 2 712 7479 f +66 2 712 7481

### DEAMARK LIMITED (Taiwan)

t +886 2 2393 1221 f +886 2 2395 1231

### KITAGAWA CO., LTD. (Korea)

t +82 2 2026 2222 f +82 2 2026 2113

## MIDDLE EAST

### LOMAS MIDDLE EAST (U.A.E)

t +971 6 551 6551

## OCEANIA

### DIMAC TOOLING PTY. LTD. (Australia)

t +61 3 9561 6155 f +61 3 9561 6705

Unit 1, The Headlands, Downton, Salisbury, Wiltshire, SP5 3JJ, UK  
[www.kitagawa.global/en](http://www.kitagawa.global/en)

Borsigstrasse 3, 40880 Ratingen, Germany  
[www.kitagawa.global/de](http://www.kitagawa.global/de)

Lysicka 3, 621 00 Brno  
[www.kitagawa.global/cz](http://www.kitagawa.global/cz)

Déry T. u. 5. H-9024 Gyor  
[www.kitagawa.global/hu](http://www.kitagawa.global/hu)

44-240 Zory, ul. Niepodleglosci 3, Poland  
[www.kitagawa.global/pl](http://www.kitagawa.global/pl)

Heliului 15, Bucharest 1, 013991, Romania  
[www.kitagawa.global/ro](http://www.kitagawa.global/ro)

Pantovcak 24, HR-10000 Zagreb  
[www.kitagawa.global/de](http://www.kitagawa.global/de)

301 E. Commerce Dr, Scaumburg, IL. 60173, USA  
[www.kitagawa.us](http://www.kitagawa.us)

Plot No. 15, 4th Phase, Bommasandra Industrial Area, Bommasandra  
Jigani Link Road, Bangalore - 560 099  
[www.kitagawa.global/in](http://www.kitagawa.global/in)

77-1 Motomachi, Fuchi-shi, Hiroshima-pref. 726-8610, Japan  
[www.kitagawa.com](http://www.kitagawa.com)

Room 1315 13F Building B, Far East International Plaza,  
No. 317 Xian Xia Road, Chang Ning, Shanghai, 20051, China

9th FL, Home Place Office Building, 283/43 Sukhumvit, 55Rd.  
(Thonglor 13), Klongtopn-Nua, Wattana, Bangkok 10110, Thailand

No. 6, Lane 5, Lin Sen North Road, Taipei, Taiwan  
[www.demark.com/tw](http://www.demark.com/tw)

803 Ho, B-Dong, Woolim Lion's Valley, 371-28 Gasan-Dong,  
Gumcheon-Cu, Seoul, Korea  
[www.kitagawa.co.kr](http://www.kitagawa.co.kr)

Lomas ME FZE, Unit Q3-107, SAIF Zone, PO Box 121499, Sharjah, UAE  
[www.kitagawa.global/ae](http://www.kitagawa.global/ae)

61-65 Geddes Street, Mulgrave, Victoria, 3170 Australia  
[www.dimac.co.au](http://www.dimac.co.au)