



**TiefbohrSysteme<sup>®</sup>** GmbH

DEEP HOLE BORING TECHNOLOGY | EQUIPMENT

## Solid Drilling Tools

Type 1455 / 1456 / 1458

DEEP HOLE DRILLING TOOLS

BORING RANGE Ø35,00 - 74,99 mm

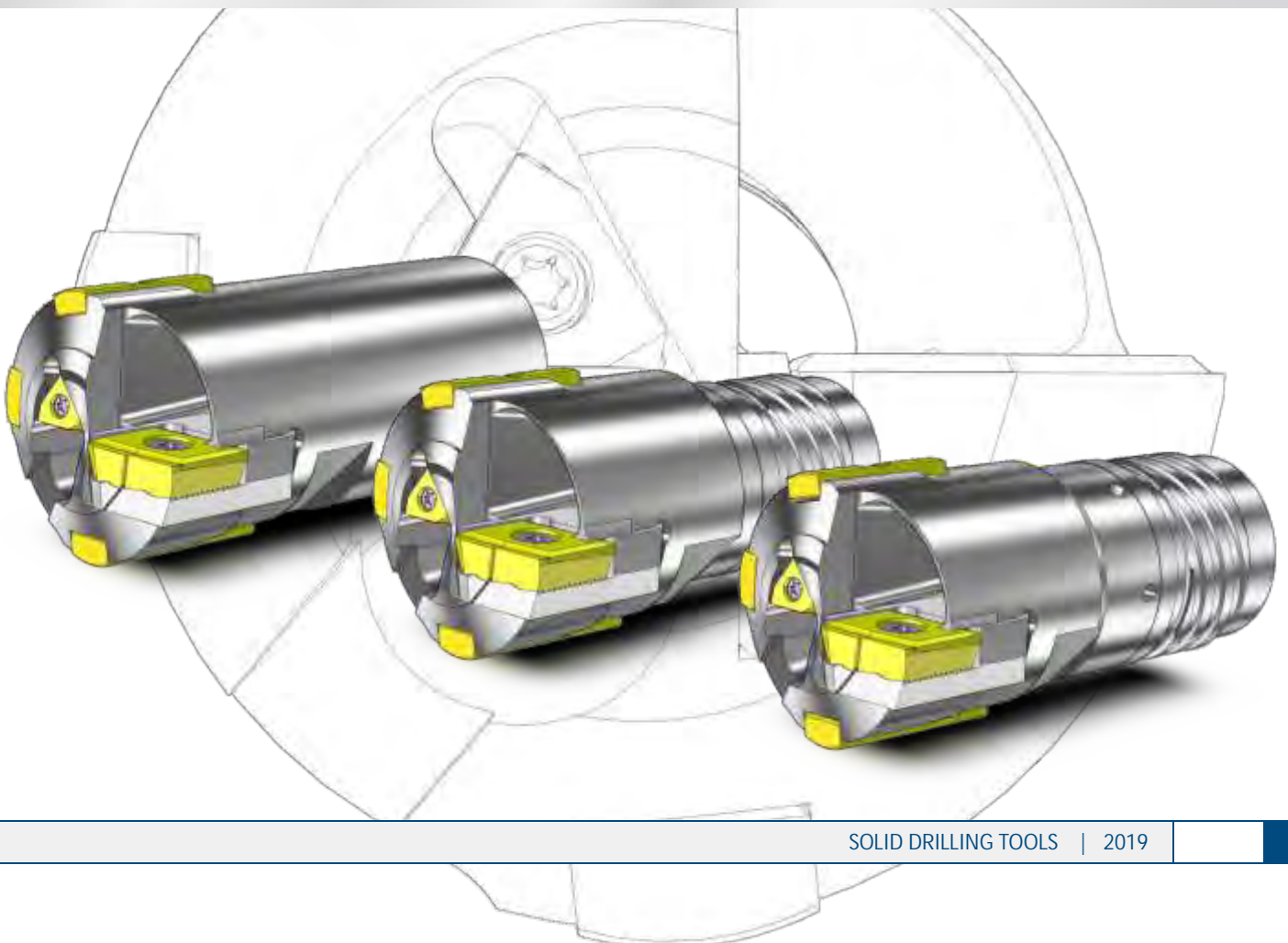

## Deep Hole Boring - An Inaccessible World

In today's production world, precision and production strategies are a significant constituent for success. The more complex the production process, the more important are these two factors. deep hole boring our company, BTA-Tiefbohrsysteme GmbH, is the essential partner for implementation even under difficult marginal conditions with high requirements. We are the only company in the world capable of offering our customers everything from inserts to complete, suitable equipment for deep hole boring machines. Our experienced experts are always at your side to ensure proper support from planning your deep hole boring project up to tool services. All this is aimed at your success.

In the company-owned application and research department we can test innovations and special designed tools, customize the tools to user-specific material and train their operators. You will receive tools customized for your application and benefit from our experience.

Our tool systems offer you the following advantages:

- Tools designed for various processes (solid boring, trepanning, counter boring and skiving) with the same effective elements, especially such as inserts and guides. This results in extremely low stocks and simple handling.
- Suitable selection possibilities for tools, corresponding to required boring quality, from simple solid boring to form boring.
- Custom layout of tools for various production requirements to straightness, surface, material and constant wall thickness.
- Equipment matched to the deep hole boring process - from workpiece clamping to vibration damping.
- Production-optimized machinery layout for reducing setup and conversion times.

Here are a few results from production boring with our tools:

- Surface Ra < 0.1 µm e.g. by skiving and roller burnishing
- Mismatch of axes < 0.1mm/m e.g. by pull counter boring
- Hole accuracy < IT8 e.g. by skiving

Benefit from these advantages by cooperating with a strong partner.

BTA-Tiefbohrsysteme GmbH





## Contents

Contents	3
Solid Drilling Tool Type 1455 - BTA thread	4
Solid Drilling Tool Type 1456 - STS thread	5
Solid Drilling Tool Type 1458 - Ejector process	6
Spare and wear parts	7

### Tool description

- Solid drilling tool with two indexable inserts and three guide pads
- The drill diameter is fixed
- Available as bta- and ejector-tool

### Tool characteristics

- drilling depth 200 x tool diameter
- surface  $R_a$  1,25  $\mu$ m
- mismatch 0,2 mm/m
- drilling accuracy IT9

## Solid Drilling Tools Type 1455

Boring range: Ø35,00 - 74,99 mm - BTA drill tube connection

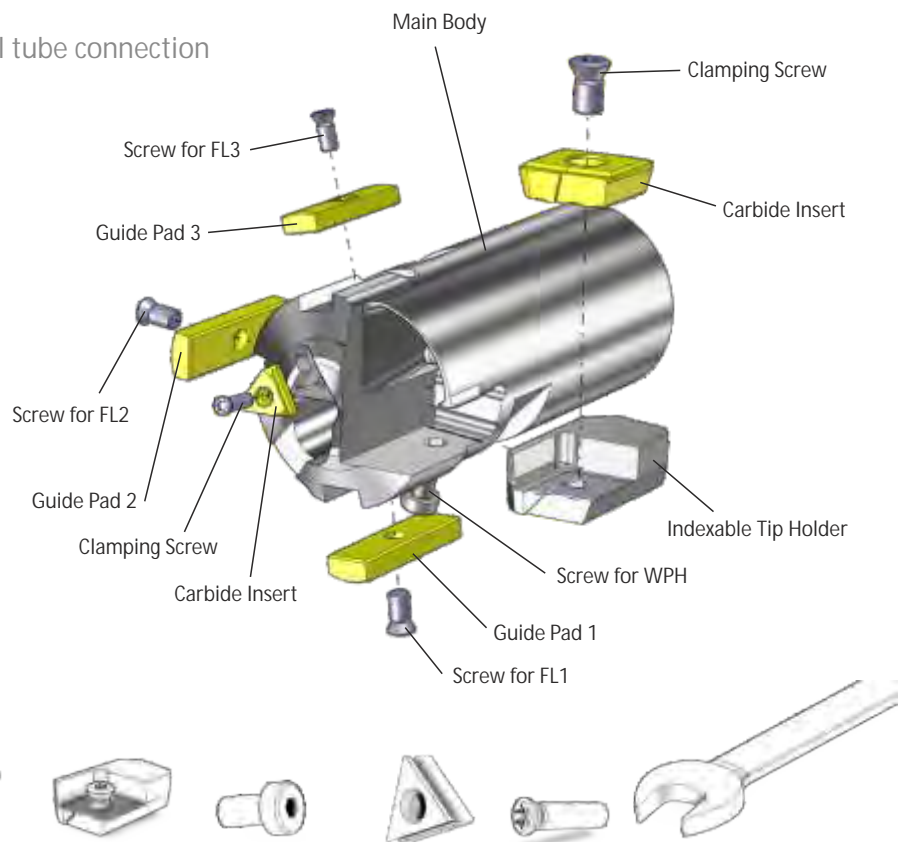

Boring Range	Drill Tube Connection	Peripheral Carbide Insert	Clamping Screw	Indexable Tip Holder	Screw for WPH	Centre Insert	Screw for Centre Insert	Wrench Size	Ident-No.
Ø 35,00 - Ø 36,99	30	A2a	M4x8,2 T15	019.6558.J	M3x6 DIN912	Z1 <sup>3</sup>		SW 27	010.8929.H
Ø 37,00 - Ø 38,50	33								
Ø 38,51 - Ø 39,99	36	A2,5a		019.6560.L	M3x8 DIN912			SW 30	008.7638.F
Ø 40,00 - Ø 42,00									
Ø 42,01 - Ø 43,99	39				M4x8 DIN7984		M2,5x10 T8	SW 32	009.0006.F
Ø 44,00 - Ø 44,50									
Ø 44,51 - Ø 46,00	43	A3a	M5x9,5 T15	019.6562.N	M4x8 DIN912			SW 34	009.0007.G
Ø 46,01 - Ø 46,99									
Ø 47,00 - Ø 49,00	47	A3,5a		020.3028.N	M4x10 DIN912	Z1,5 <sup>3</sup>		SW 36	010.8030.N
Ø 49,01 - Ø 51,00									
Ø 51,01 - Ø 51,99	51			020.1494.D	M5x12 DIN912			SW 41	009.0008.H
Ø 52,00 - Ø 54,00									
Ø 54,01 - Ø 56,99	56	A4a	M5x12 T15		M5x12 DIN912			Groove for hookwrench according worksheet <b>100.0011.M</b>	
Ø 57,00 - Ø 60,99									
Ø 61,00 - Ø 64,99	62	A5a	M6x12 T20	020.2789.P	M6x16 DIN912	Z2 <sup>3</sup>	M3,5x15 T15		
Ø 65,00 - Ø 67,99									
Ø 68,00 - Ø 74,99									

See Page 7 for Cutting Inserts, Guide Pads and Screws/Wrench ordering data



## Solid Drilling Tool Type 1456

Boring range: Ø35,00 - 74,99 mm - STS drill tube connection

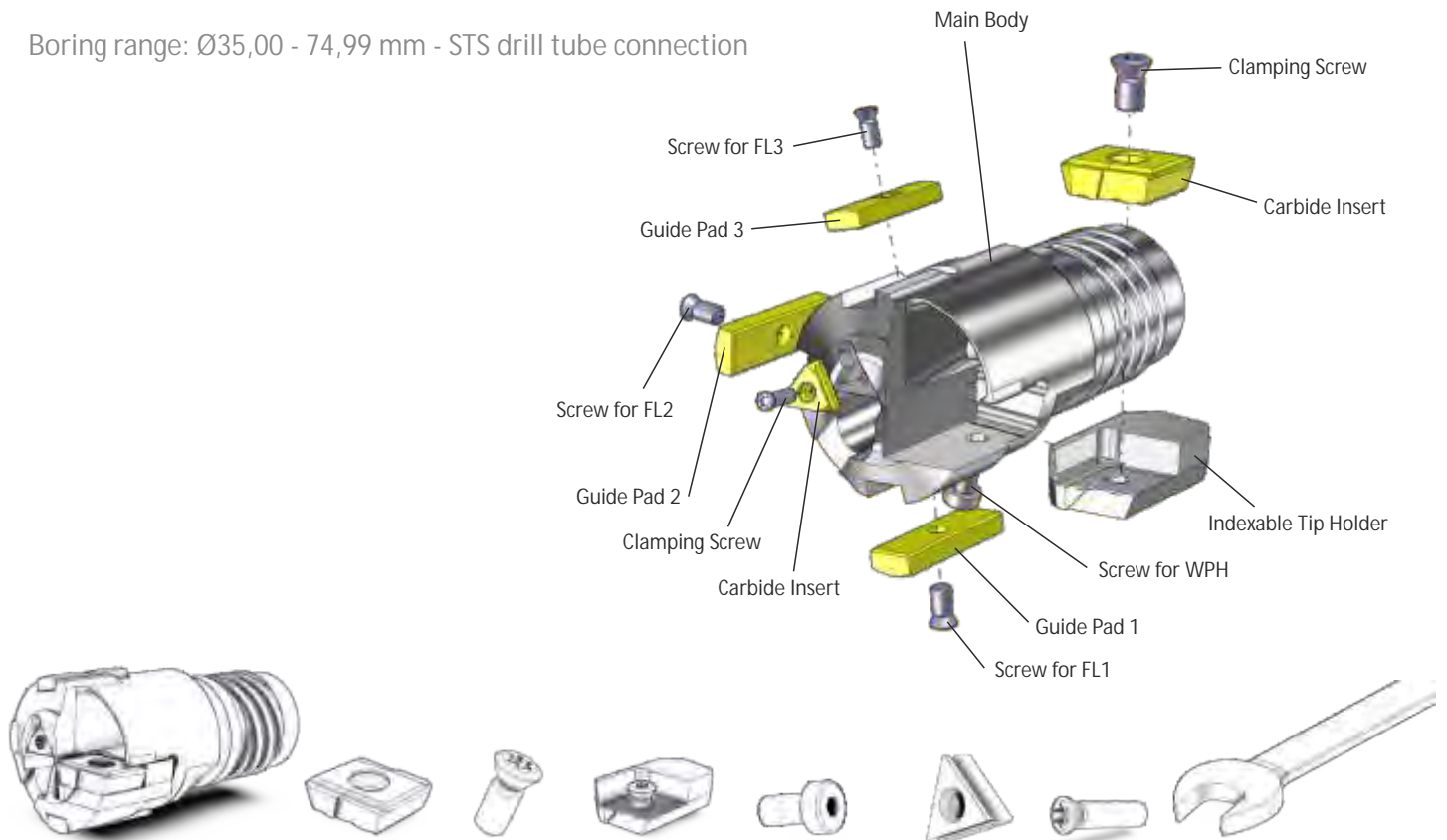

Boring Range	Drill Tube Connection	Peripheral Carbide Insert	Clamping Screw	Indexable Tip Holder	Screw for WPH	Centre Insert	Screw for Centre Insert	Wrench Size	Ident-No.
Ø 35,00 - Ø 36,20	33	A2a	M4x8,2 T15	019.6558.J	M3x6 DIN912			SW 27	010.8929.H
Ø 36,21 - Ø 38,50									
Ø 38,51 - Ø 39,60									
Ø 39,61 - Ø 42,00	36	A2,5a		019.6560.L	M3x8 DIN912	Z1 <sup>3</sup>		SW 30	008.7638.F
Ø 42,01 - Ø 43,00									
Ø 43,01 - Ø 44,50	39				M4x8 DIN7984		M2,5x10 T8	SW 32	009.0006.F
Ø 44,51 - Ø 46,00									
Ø 46,01 - Ø 47,00	43	A3a	M5x9,5 T15	019.6562.N	M4x8 DIN912			SW 34	009.0007.G
Ø 47,01 - Ø 49,00									
Ø 49,01 - Ø 51,00									
Ø 51,01 - Ø 51,70	47	A3,5a		020.3028.N	M4x10 DIN912	Z1,5 <sup>3</sup>		SW 41	009.0008.H
Ø 51,71 - Ø 54,00									
Ø 54,01 - Ø 56,20	51	A4a	M5x12 T15	020.1494.D	M5x12 DIN912			SW 36	010.8030.N
Ø 56,21 - Ø 61,00									
Ø 61,01 - Ø 64,99									
Ø 65,00 - Ø 69,84	56	A5a	M6x12 T20	020.2789.P	M6x16 DIN912	Z2 <sup>3</sup>	M3,5x15 T15	SW 41	009.0008.H
Ø 69,85 - Ø 74,99									
									Groove for Hookwrench according worksheet <b>100.0011.M</b>

See Page 7 for Cutting Inserts, Guide Pads and Screws/Wrench ordering data



## Solid Drilling Tools Type 1458

Boring range: Ø35,00 - 74,99 mm - Ejector drill tube connection

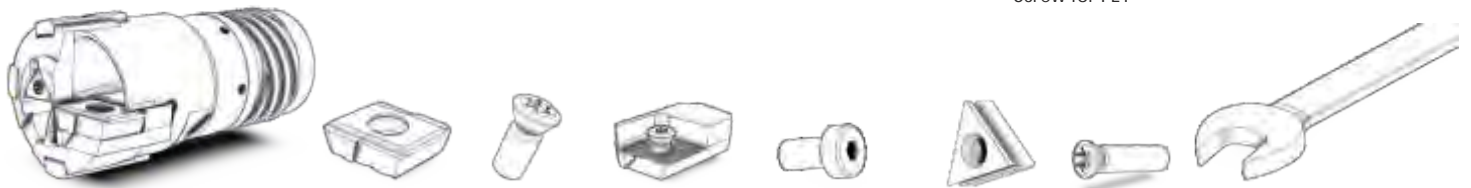
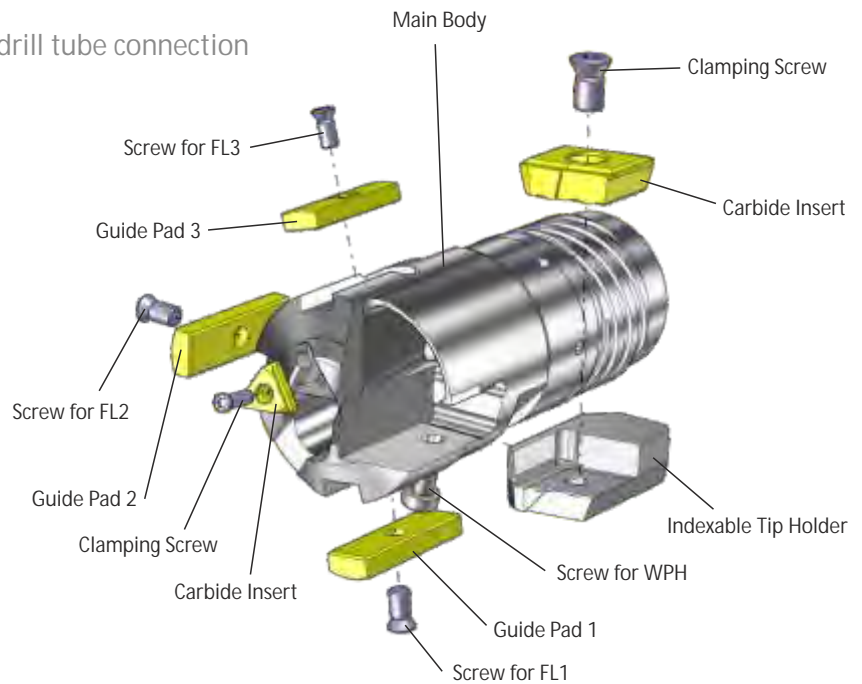

Boring Range	Drill Tube Connection	Peripheral Insert	Clamping Screw	Indexable Tip Holder	Screw for WPH	Centre Insert	Screw for Centre Insert	Wrench Size	Ident-No.
Ø 35,00 - Ø 36,20	33	A2a	M4x8,2 T15	019.6558.J	M3x6 DIN912	Z1 <sup>3</sup>		SW 27	010.8929.H
Ø 36,21 - Ø 38,50	35,5								
Ø 38,51 - Ø 39,60	39	A2,5a		019.6560.L	M3x8 DIN912			SW 30	008.7638.F
Ø 39,61 - Ø 42,00									
Ø 42,01 - Ø 43,00	42,5				M4x8 DIN7984			SW 32	009.0006.F
Ø 43,01 - Ø 44,50									
Ø 44,51 - Ø 46,00	46,5	A3a	M5x9,5 T15	019.6562.N	M4x8 DIN912			SW 34	009.0007.G
Ø 46,01 - Ø 47,00									
Ø 47,01 - Ø 49,00	51	A3,5a		020.3028.N	M4x10 DIN912	Z1,5 <sup>3</sup>		SW 36	010.8030.N
Ø 49,01 - Ø 51,00									
Ø 51,01 - Ø 51,70	55,5	A4a	M5x12 T15	020.1494.D	M5x12 DIN912			SW 41	009.0008.H
Ø 51,71 - Ø 54,00									
Ø 54,01 - Ø 56,20	56	A5a	M6x12 T20	020.2789.P	M6x16 DIN912	Z2 <sup>3</sup>	M3,5x15 T15	Nut für Hakenschlüssel n. Arbeitsblatt <b>100.0011.M</b>	
Ø 56,21 - Ø 60,99									
Ø 61,00 - Ø 65,00	62								
Ø 65,01 - Ø 69,99									
Ø 70,00 - Ø 74,99									

See Page 7 for Cutting Inserts, Guide Pads and Screws ordering data



## Spare and wear parts

For Solid Drilling Tools Type 1455 / 1456 / 1458

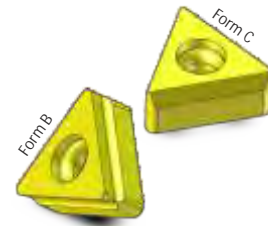

Indexable Inserts size A2a - A5a; Z1<sup>3</sup> - Z2<sup>3</sup>

Description	Chip Breakers	Carbide		
		P25 TiN	P40 TiN	K20 TiN
A2a	Size 1 - 2,2x0,5	018.9896.T	019.2603.P	019.2541.Z
	Size 2 - 2,5x0,7	019.2337.M	019.2607.T	019.2545.D
A2,5a	Size 1 - 2,2x0,6	019.5844.Q	019.6621.Z	019.6623.B
	Size 2 - 2,5x0,6	019.6620.Y	019.6622.A	019.6624.C
A3a	Size 1 - 2,5x0,7	018.9897.U	019.2604.Q	019.2542.A
	Size 2 - 2,7x0,8	019.2338.N	019.2608.U	019.2546.E
A3,5a	Size 1 - 2,5x0,7	020.3025.K	-	-
A4a	Size 1 - 2,5x0,7	018.9898.V	019.2605.R	019.2543.B
	Size 2 - 2,7x0,8	019.2348.Y	019.2609.V	019.2547.F
A5a	Size 1 - 2,7x0,8	018.9899.W	019.2606.S	019.2544.C
	Size 2 - 3,0x1,0	019.2349.Z	019.2610.W	019.2548.G

Description	Chip Breakers	Carbide		Cutting edges
		B TiN	H TiN	
Z1 <sup>3</sup>	2,1 x 0,5 / form B	019.6501.Z	019.6502.A	3
	negativ / form C	019.6503.B	019.6504.C	
Z1,5 <sup>3</sup>	2,5 x 0,8 / form B	019.6711.T	019.6574.A	
	negativ / form C	019.6713.V	019.6714.W	
Z2 <sup>3</sup>	2,5 x 0,8 / form B	019.6497.V	019.6498.W	6
	negativ / form C	019.6499.X	019.6500.Y	

Carbide „B“ (hard) for structural steel  
Carbide „H“ (tough) for alloyed and stainless steels

Chip breaker size 1 for unalloyed steels C > 0.2, alloyed steels, heat-treated steels, tool steel  
Chip breaker size 2 for unalloyed steels C < 0.2, long chipping special purpose steel, stainless and acid-resistant steel

Additional chip breakers and coatings on request

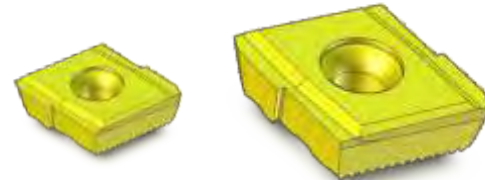

## Guide Pads

Position	Boring Range	Description	Radius	Carbide		Screws for Guide Pads
				TiN coated	ML coated	
Guide Pad 1 and 2	Ø 35,00 - Ø 38,50	FL 8	10	014.4757.G	019.6676.G	M3x7,4 T9
	Ø 38,51 - Ø 51,99	FL 9	12,5	014.4758.E	019.6678.J	M4x8,2 T15
	Ø 52,00 - Ø 64,99	FL 10	20	016.9223.G	019.6679.K	
	Ø 65,00 - Ø 74,99	FL 14	30	016.9229.T	019.6681.M	
Guide Pad 3	Ø 35,00 - Ø 64,99	FL 8	10	014.4757.G	019.6676.G	M3x7,4 T9
	Ø 65,00 - Ø 74,99	FL 10	20	016.9223.G	019.6679.K	M4x8,2 T15



## Screws and Wrenches



Size	Length	Ident-No. Clamping Screw	Torx Size	Ident-No. Torx-Screw
M2,5	5	010.8405.U	T8	010.8812.F
	10	010.8778.C		
M3	7,4	008.1065.L	T9	008.1104.D
	10	010.7674.V		
M3,5	15	010.8779.A	T15	008.7219.C
M4	8,2	008.1066.J		
	9,5	014.4779.V		
M5	12	008.1067.G		
	12	008.1068.E	T20	008.7220.T



Size	Length	Ident-No. Clamping Screw	SW Size	Ident-No. Hexagon-Wrench
M3 / DIN 912	6	010.8525.J	SW 2,5	008.5836.M
	8	008.5106.C		
M4 / DIN 912	8	008.7044.M	SW 3	008.6741.T
	10	008.5108.X		
M5 / DIN 912	12	008.5109.V	SW 4	008.5837.K
	12	008.5115.B		
M6 / DIN 912	16	008.5121.G	SW 5	008.5838.H



BTA-Tiefbohrsysteme GmbH  
Hainkämpe 12  
28832 ACHIM  
GERMANY

Tel. +49 (0) 4202 / 96 84 - 5  
Fax. +49 (0) 4202 / 96 84 - 70

e-mail [info@bta-tiefbohrsysteme.com](mailto:info@bta-tiefbohrsysteme.com)  
Internet [www.bta-tiefbohrsysteme.com](http://www.bta-tiefbohrsysteme.com)

Our program:



The catalogs are for information only and not subject to change service. Printing errors, mistakes and technical changes excepted. For further information please contact the above address.