

Milling Cutter



Milling Cutter for Ceramic Inserts

Characteristics

Negative milling cutter with 75° approach angle.

Its strong insert shape allows high depth of cut and heavy feed.

Applications



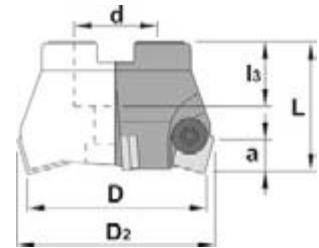
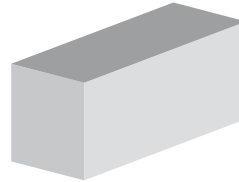
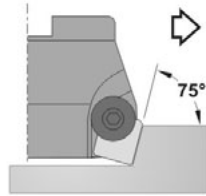
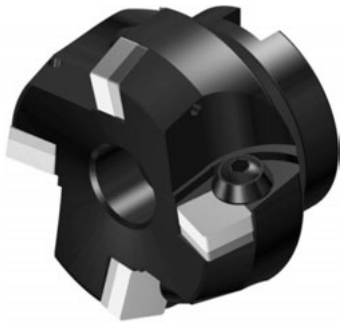



Cast iron milling



● 0442 90 75°

Item-No.	D	Teeth	D2	L	d	l3	a	Insert	Weight
044290050-C	50	3	56	40	22	20	9	SN..1204	0.38
044290063-C	63	4	69	50	27	22	9		0.75

● Parts



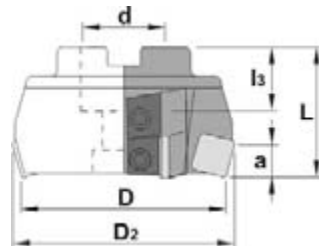
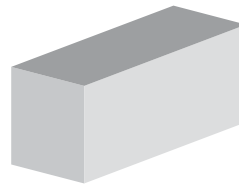
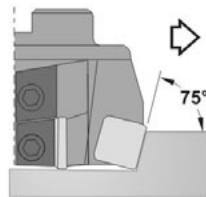



Item-No.						
	Clamp screw	Wrench	Clamp	Shim	Shim screw	Clamping bolt
044290050-C	1006	LW-4	2066	3212	4012	912.10
044290063-C						912.12



● 0442 99 75°

Item-No.	D	Teeth	D2	L	d	l3	a	Insert	Weight
044299080-C	80	5	86	50	27	22	9	SN..1204	1.2
044299100-C	100	7	106	50	32	25	9		1.95
044299125-C	125	8	131	63	40	30	9		3.25





● Parts

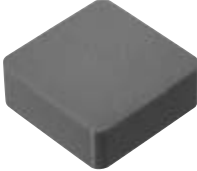
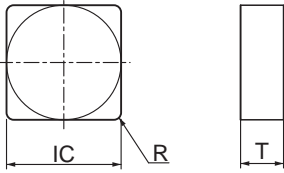
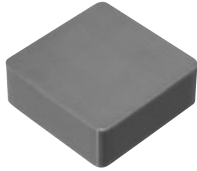
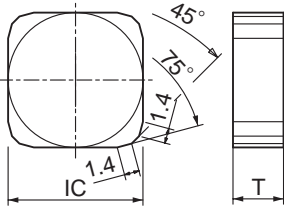
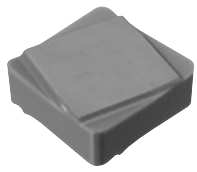
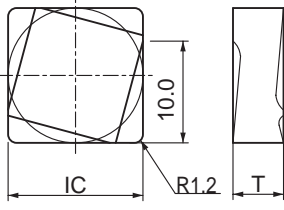



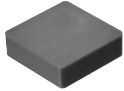
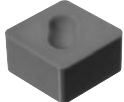
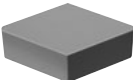

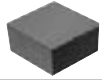
Item-No.							
	Wedge screw	Wedge	Wedge	Cartridge	Adjust screw	Clamping bolt	Driver
044299080-C	1077	6432	6438	6912	1460	912.12	5620
044299100-C						912.17	
044299125-C							

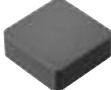
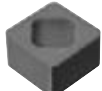
Inserts for Milling Cutter

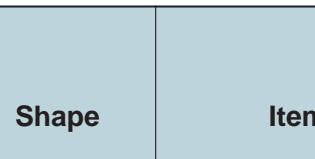
Shape	Dimension	IC	T	Item-No. IC T R	SX1
		12.7	4.76	SNGN 120408 TNF (T02025) 120412 TNF (T02025) 120416 TNF (T02025) 120420 TNF (T02025) 120424 TNF (T02025)	● ● ●
		12.7	4.76	Wiper SNGN 1204 ENTN (T01025)	●
		12.7	4.76	SNGF 120412 TRCC413 (T01025)	●

● NTK ceramic inserts

Shape	Item-No.	Dimenstions			Ceramics												
		IC	T	R	Silicon-nitride				Alumina				Whisker				
					SX1	SX9	SX8	SP2	HC1/HW2	HC2	HC4/ZC4	HC6	HC7/ZC7	WA1			
	CNGN 120408 120412 120416 120708 120712 120716	12.7	4.76	0.8	●	●	●		●	●	●	●	●	●	●		
				1.2	●	●	●		●	●	●	●	●	●			
				1.6	●	●	●	●	●	●	●	●	●	●			
			7.94	0.8	●	●	●	●	●	●	●	●	●	●	●	●	
				1.2	●	●	●	●	●	●	●	●	●	●	●	●	
				1.6	●	●	●	●	●	●	●	●	●	●	●	●	
	CNGX 120708--DP5 120712--DP5 120716--DP5 120720--DP5 160708--DP5 160712--DP5 160716--DP5 160720--DP5 160732--DP5	12.7	4.76	0.8	●	●			●								
				1.2	●	●			●								
				1.6	●	●			●								
		7.94	4.76	0.8	●	●											
				1.2	●	●											
				1.6	●	●											
		15.875	7.94	0.8	●	●											
				1.2	●	●											
				1.6	●	●											
15.875	7.94	2.0	●	●													
		3.2	●	●													
		3.2	●	●													
	DNGN 150408 150412	12.7	4.76	0.8					●		●			●			
				1.2					●					●			
	DNGX 120708--DP5 120712--DP5 120716--DP5 120720--DP5 150708--DP5 150712--DP5 150716--DP5 150720--DP5	9.525	4.76	0.8	●	●				●							
				1.2	●	●				●							
				1.6	●	●				●							
		7.94	4.76	2.0	●	●											
				0.8	●	●				●							
				1.2	●	●				●							
		12.7	4.76	1.6	●	●						●					
				2.0	●	●						●					
				2.0	●	●						●					
	ENGN 130708 130712 130716	12.7	7.94	0.8			●		●	●							
				1.2			●		●	●							
				1.6			●		●	●							
	RNGN 120400 120700 150700 190700 250700	12.7	4.76		●	●		●	●	●		●	●	●			
					●	●	●	●	●		●	●	●				
		15.875	7.94				●			●	●	●		●	●		
							●			●	●	●		●	●		
									●		●	●		●	●		
	SNGN 090308 090316 090404 090408 090412 120404 120408 120412 120416 120420 120424 120432 150716 190716 190720 190724 250720 250724	9.525	3.18	0.8					●	●							
				1.6			●										
				0.4													
		12.7	4.76	4.76	0.4						●	●					
					0.8						●	●					
					1.2		●				●	●					
				7.94	4.76	0.8	●	●			●	●		●		●	●
						1.2	●	●	●	●	●	●	●		●	●	●
						1.6	●	●	●	●	●	●	●		●	●	●
		15.875	7.94	7.94	2.0		●			●		●					
					2.4		●										
					3.2		●	●		●							
		19.05	7.94	7.94	1.6	●	●	●	●		●	●			●	●	
					2.0					●	●			●	●	●	
					2.4	●					●	●			●	●	
		25.4	7.94	7.94	2.0						●	●			●	●	
					2.4					●	●			●	●	●	
			SNGX 120708--DP5 120712--DP5 120716--DP5 120720--DP5	12.7	7.94	0.8	●	●									
1.2	●					●											
1.6	●					●											
2.0	●					●											

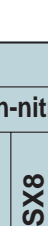
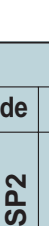
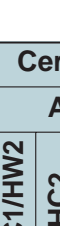
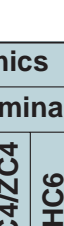
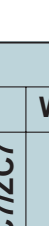
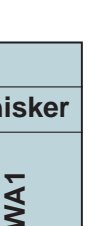
Shape	Item-No.	Dimenstions			Ceramics													
		IC	T	R	Silicon-nitride				Alumina				Whisker					
					SX1	SX9	SX8	SP2	HC1/HW2	HC2	HC4/ZC4	HC6	HC7/ZC7	WA1				
	TNGN	110308	6.35	3.18	0.8						●							
	160304				0.4													
	160404	9.525	4.76	0.4					●	●				●		●		
	160408			0.8	●	●		●	●	●		●	●					
	160412			1.2	●	●	●		●	●	●		●	●				
	160416			1.6	●	●		●	●	●		●	●					
	160420			2.0		●			●	●	●		●					
	160708	9.525	7.94	0.8			●		●	●								
	160712			1.2			●		●	●								
	160720			2.0														
	220408	12.7	4.76	0.8						●			●					
	220412			1.2													●	
	VNGN	160404	9.525	4.76	0.4						●	●						
	160408				0.8					●	●							
	160412				1.2													
	160416				1.6													
	VNGX	160704--DP5	9.525	4.76	0.4	●	●											
	160708--DP5				0.8	●	●											
	160712--DP5				1.2	●	●											
	160716--DP5				1.6	●	●											
	CNGA	120404	12.7	4.76	0.4						●	●			●			
	120408				0.8	●	●	●	●	●	●	●			●	●		
	120412				1.2	●	●	●	●	●	●	●			●	●		
	120416				1.6	●	●		●	●	●	●			●	●		
	DNKA	150404	12.7	4.76	0.4						●	●			●			
	150408				0.8	●	●			●	●			●	●			
	150412				1.2	●	●			●	●			●	●			
	SNGA	120404	12.7	4.76	0.4						●	●						
	120408				0.8	●	●	●		●	●	●						
	120412				1.2	●	●		●	●	●							
	120416				1.6	●	●			●	●							
	TNGA	160404	9.525	4.76	0.4				●		●	●			●			
	160408				0.8	●	●	●	●	●	●	●			●	●		
	160412				1.2	●	●		●	●	●				●	●		
	VNGA	160404	9.525	4.76	0.4					●	●	●			●			
	160408				0.8			●		●	●	●	●		●	●		
	160412				1.2					●	●				●	●		
	WNGA	080408	12.7	4.76	0.8		●		●			●	●					
	080412				1.2	●	●	●	●									
	080416				1.6	●	●											
	SPGN	090308	9.525		0.8						●							
	120308	12.7	3.18	0.8			●			●	●		●					
	120312			1.2			●		●	●								
	120408	4.76	4.76	0.8						●	●							
	120412			1.2							●	●						
120416	1.6																	
	TBGN	060104	3.97	1.59	0.4							●						
	060108				0.8													
	TPGN	090204	9.525	2.36	0.4						●							
	090208			0.8						●	●							
	110304	6.35	3.18	0.4			●		●	●	●	●	●	●				
	110308			0.8					●	●	●	●	●	●	●			
	160304	9.525	4.76	0.4						●	●	●			●			
	160308			0.8						●	●	●			●	●		
	220408			0.8							●	●	●			●	●	
	12.7	4.76	0.8									●	●					

End Milling Tools



Indexable Milling Tools P.200

Gear Tooth Chamfering Tools P.206

Small Diameter Indexable End Mills for CNC Auto lathes

Best for D-cutting!!

<Features>

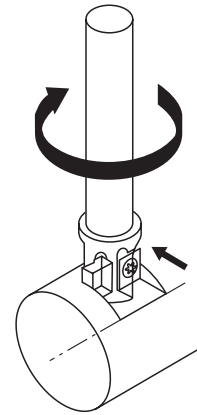

- The use of ZM3 inserts achieves high speed machining at three to five times that of a conventional high-speed steel end-milling tool.
- Surface quality can be improved to about 5 microns Rz.
- REZ type allows square corner cutting.

φ8 mm Dia. tools are now available !!



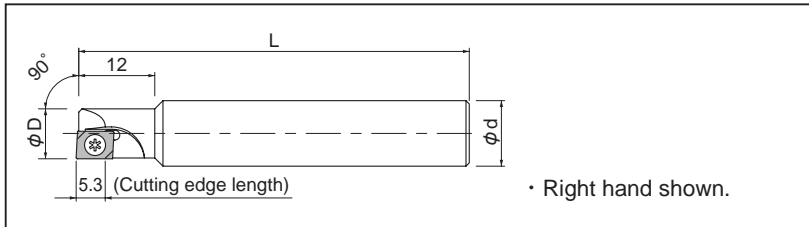

RE

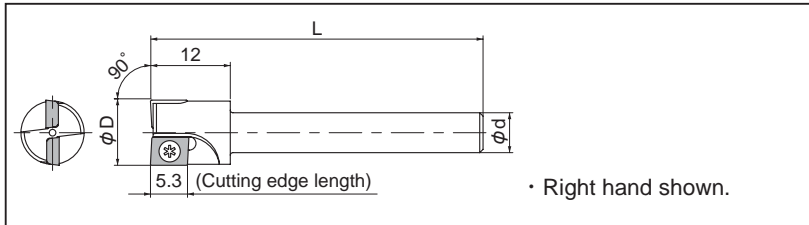

Clamping screw	Wrench
FSI02-2.2×4.0	T-07
	
Note	

Item-No.	Stock	Number of teeth	Dimensions (mm)			inserts
			φD	L	φd	
REZ080C1R212	●	1	8	60	10	CZH040



Clamping screw	Wrench
FSI02-2.2×4.0	T-07
	
Note	

Item-No.	Stock	Number of teeth	Dimensions (mm)			Applicable inserts
			φD	L	φd	
REZ100C2R133	●	2	10	50	6	CZH040□□□CFR-070
R132	●				7	
R141	●				10	

● Insert

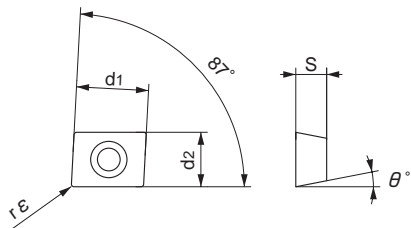

Note : Extended use could result in unusual screw wear, making it impossible to fully tighten the screw. Therefore, please replace the screw regularly.

Item-No.	Stock	ItemsDimensions (mm)				
	ZM3	d1	d2	S	θ	rε
CZH04005CFR-070	●	5.56	4.2	1.88	7	0.05
CZH0402CFR-07	●					0.2

● Recommended Cutting Condition (X5CrNi18-9)

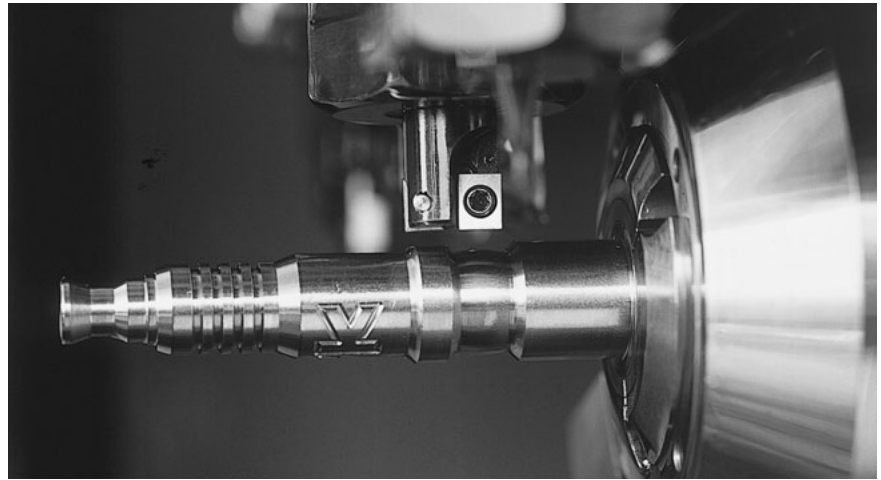
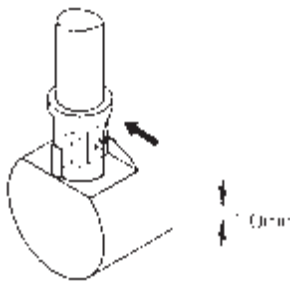
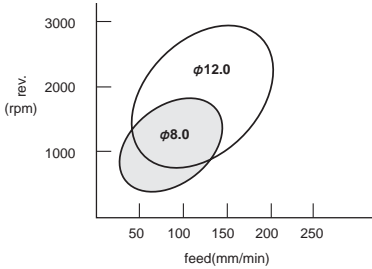

Material : X5CrNi18-9
 Diameter : $\phi 8.0$ and $\phi 12.0$
 Depth of cut : 1.0mm
 Insert : ZM3CZH0402CFR-070
 Toolholder : REZ100CZR141
 Note : The smaller the workpiece diameter becomes, the more chattering occurs.
 When chattering occurs, please decrease speed and feed.

● Application Example

Slow away end mill machining by ZM3.			
	Current tool	NTK	Work piece
Insert Number	Standard	CZH0402CFR-070	Material X5CrNi18-9
Grade	PVD coated carbide	ZM3	
Rev.	1,200 rpm	1,200 rpm	
Cutting speed	38 m/min	38 m/min	
Feed	36 mm/min	72 mm/min	
Depth of cut	2.5 mm	2.5 mm	
Coolant	Yes	←	
Tool life	200 pcs	1200 pcs	

End mill (D cut) by ZM3.			
	Current tool	NTK	Work piece
Insert Number	Solid end mill (N.O.B 4)	CZH0402CFR-070 (N.O.B 2)	Material X6Cr17
Grade	Coated carbide	ZM3	
Rev.	2,500 rpm	1,500 rpm	
Cutting speed	78.5 m/min	47.1 m/min	
Feed	100 mm/min	200 mm/min	
Depth of cut	1.0 mm	1.0 mm	
Coolant	Yes	←	
Tool life	5000 pcs	8000 pcs	

Note : Current tool suffered wear and poor size control. NTK cycle time was double with an increase in a tool life.

Note : NTK type End-Mill eliminated the need for re-grinding. Cycle time was halved and tool life was 1.6 times longer.

RE

Diameter $\phi 10$, Shank Diameter $\phi 7$

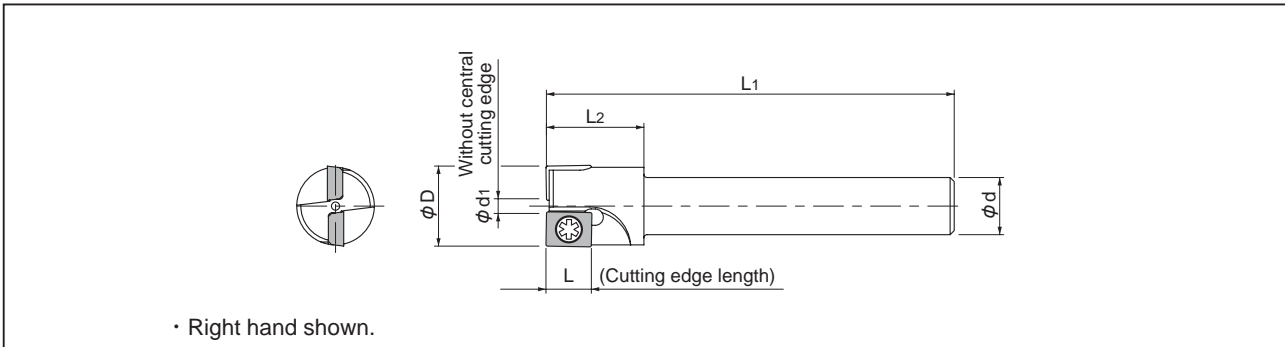

Toolholder	Stock	Number of teeth	Dimensions (mm)							Insert
			ϕD	H	L1	L2	L	ϕd	$\phi d1$	
REL100C2R107	●	2	10	/	50	12	(5.3)	7	(1.2)	CLH04005CFN-045 CLH0402CFN-0450

RE

Diameter $\phi 10$, Shank Diameter $\phi 10$

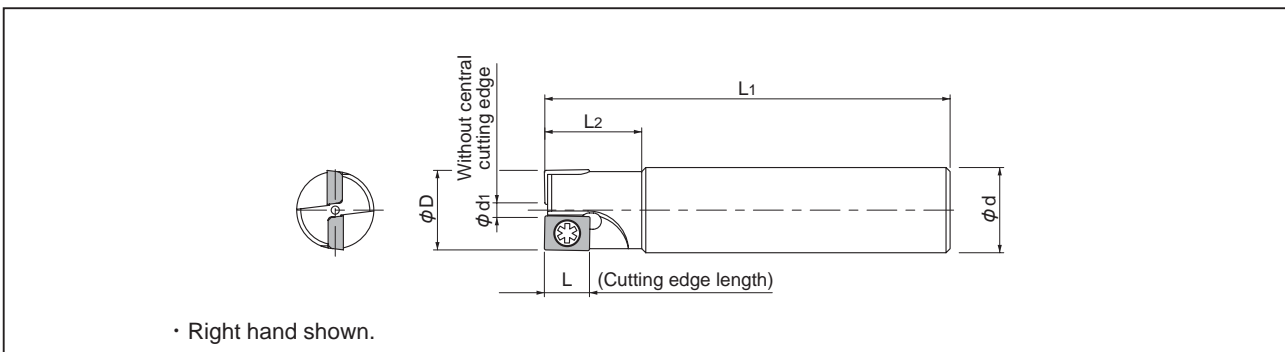

Toolholder	Stock	Number of teeth	Dimensions (mm)							Insert
			ϕD	H	L1	L2	L	ϕd	$\phi d1$	
REL100C2R106	○	2	10	/	50	12	(5.3)	10	(1.2)	CLH04005CFN-045 CLH0402CFN-0450

RE

Diameter $\phi 10 \sim \phi 14$

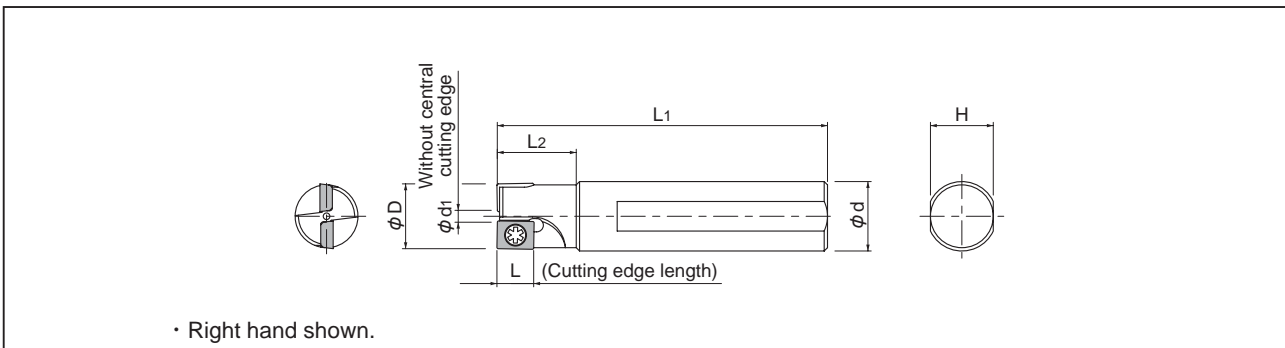

Toolholder	Stock	Number of teeth	Dimensions (mm)							Insert
			ϕD	H	L1	L2	L	ϕd	$\phi d1$	
REL100C2R043	●	2	10	9.5	50	12	(5.3)	10	(1.2)	CLH04005CFN-045
RES120C2R048	○		12	11.5						
RES140D2R047	○		14	13.5	55	15	(5.3)	14	(3.4)	

● Insert

CLH,CSH

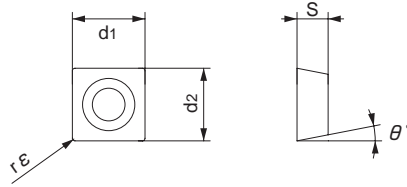
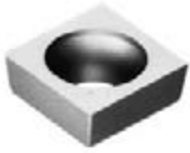

• Right hand shown.

Insert Number	Stocked item	Dimensions (mm)				
	Micro grain carbide	d1	d2	S	θ°	rE
	ZM3					
CLH04005CFN-045 0402 CFN-045	○ ●	5.56	4.20	1.88	7	0.05
CSH0402 CFN-020 0502 CFN-019	○ ○	4.86 5.56	4.86 5.56	2.18 2.38		11

● Parts

Parts	Clamping screw	Wrench
Toolholder		
REL100C2R043 REL100C2R106 REL100C2R107	FSI02-2.2×4.3	T-07
RES120C2R048 RES140D2R047	FSI02-2.2×5.6	

● Notice for Using Type REL

Taper angles occur in the workpiece in the following sizes, if you use REL type end mill.

Depth of cut (mm)	Top face machining diameter - Bottom face machining diameter (mm)	
2	0.05	<p>Edge angle is 1° with REL type.</p>
3	0.08	
4	0.12	
5	0.15	



The 8-mm Dia.cutter has made its debut as a member of the Small Diameter Indexable End-Mills forming which is now enjoying a favorable reputation. In addition to conventional special design for D-cutting, new inserts each with a centre cutting edge are now available to allow slotting, angle cutting, and helical cutting. Changing from the conventional solid End-mill to the throwaway type makes re-grinding and re-coating unnecessary, thus permitting significant reduction in setup time.

● Features

- The use of 8mm-diameter and 10mm-diameter throw-away end milling tools makes re-grinding and re-coating unnecessary.
- End-milling tools with a centre cutting edge are available for roughing and semi-finishing.
- A variety of machining patterns can be created using the centre cutting edge.

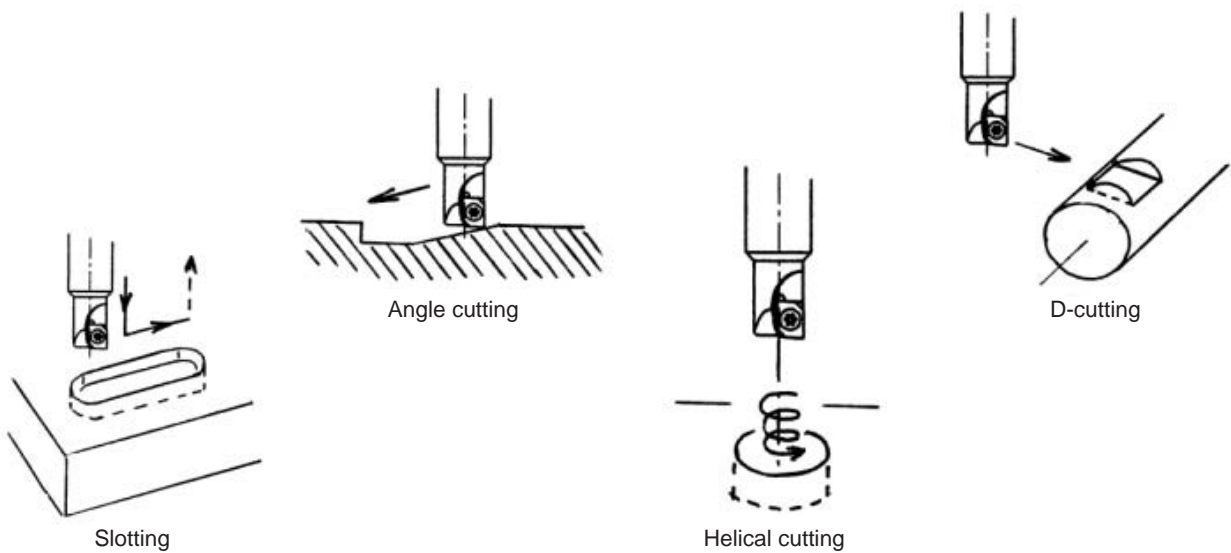

- An insert with a wiper facet allows components to be machined to 1-micron Rz surface quality (JIS-spec).

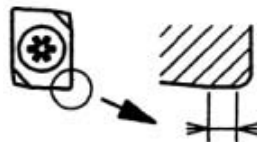

● Recommended Condition

Work Material	Speed V(m/min)	Axial feed f(mm/rev)	Transversal feed f(mm/rev)	Depth of cut t(mm)
General steel	80~120	~ 0.03	~ 0.05	~ 3.0
Stainless	40~60	~ 0.02	~ 0.04	~ 2.0

● Toolholder

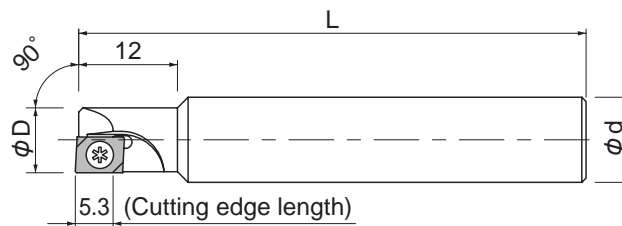

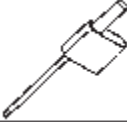
Toolholder	Stock	Dimensions				Parts		Insert
		φD	Number of teeth	φd	L	Clamping screw	Wrench	
								
REZ080C1R212	-	8	1	10	60	FSI02-2.2×4.0	T-07	CZH04
REZ100C1R218	-	10	1	10	75	FSI02-2.2×4.3	T-07	CZH05

● Insert

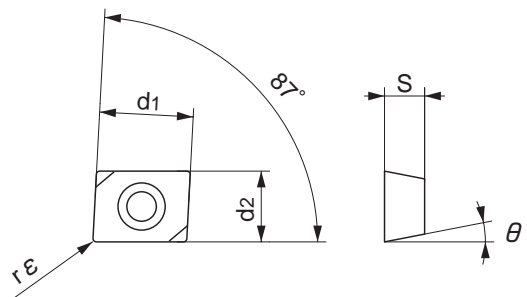

Item-No.	Dimensions					Center blade	Wiper	Grade	
	d1	d2	S	θ	rε			ZM3	TA3
CZH 0402CFR-140 04005CFR-140 0402CFR-070 04005CFR-070	5.56	4.2	1.88	7	0.2	○	○	●	
					0.05	○	○	●	
					0.2	×	×	●	
					0.05	×	×	●	
0502CFR-141 05005CFR-141	5.28	5.56	2.18	10	0.2	○	○	●	
					0.05	○	○	●	

Throw-Away End-Milling Tools for Gear Tooth Chamfering

Changing from the conventional solid type end-mill to the throw-away type can be implemented.

<Features>

- (1) Surface finish can be improved.
- (2) Shape and accuracy are stabilized.
- (3) Compared to that of a high-speed end-milling tool, life can be extended by a full order of magnitude.
- (4) These new products can be used under the same machining conditions as those of existing products such as high-speed end-milling tools.
- (5) Compared to that of a single-edge throw-away type, long tool life can be obtained.

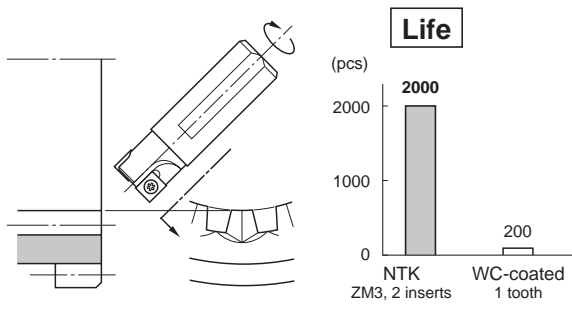
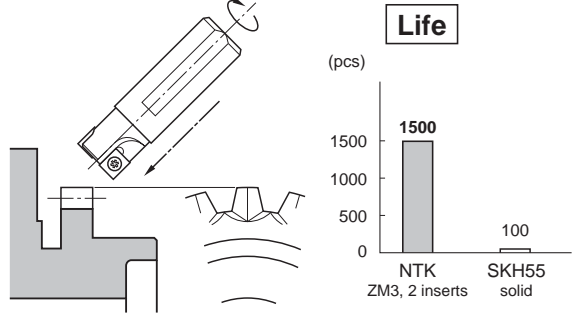

● Examples

Sleeve rectangular tooth chamfering	Speed gear oblique chamfering
 <p>Life</p> <p>(pcs)</p> <p>2000</p> <p>200</p> <p>NTK ZM3, 2 inserts</p> <p>WC-coated 1 tooth</p>	 <p>Life</p> <p>(pcs)</p> <p>1500</p> <p>100</p> <p>NTK ZM3, 2 inserts</p> <p>SKH55 solid</p>
<p>Cutting conditions</p> <p>Work material : 15CrMo4</p> <p>No. of revolutions (N) : 3,500min⁻¹</p> <p>Cutting speed (V) : 154m/min</p> <p>Coolant : Wet (Oily)</p> <p>Grade : ZM3</p> <p>Insert No. : CLH0504CFN</p> <p>Holder No. : RCL140D2^{R/L}021</p>	<p>Cutting conditions</p> <p>Work material : 20CrS4 (HB140 - 230)</p> <p>No. of revolutions (N) : 955min⁻¹</p> <p>Cutting speed (V) : 42m/min</p> <p>Coolant : Wet (Oily)</p> <p>Grade : ZM3</p> <p>Insert No. : CLH0502CFN</p> <p>Holder No. : RCL140D2^{R/L}021</p>

Operating Precautions on NTK Throw-Away End-Milling Tools for Gear Tooth Chamfering

① Cutter diameters and machining conditions

Cutter diameter	Recommended depth of cut	Recommended feed rate
$\phi 14$	2.25 or less	0.3 mm/rev or less
$\phi 12$	2.15 or less	0.3 mm/rev or less

If the recommended depth of cut or the recommended feed rate is exceeded, clamping screws should be retightened at least once or twice a day.

② The amount of overhang of the end-milling tool

When mounting the end-milling tools, adjustments for a minimum amount of overhang from the chuck to the tool nose should be made in order to prevent run out during machining. (Target value: approx. 20 mm)

③ Durability of the holder

As is known, rectangular tooth chamfering usually applies shock load to the tool at a rate of up to 500,000 times a day. Therefore, the holder, the durability of which depends on actual operating conditions, is usually designed so that the body can be used for several months.

However, as the deformation of the wrench hole in the clamping screw progresses, the tightening torque applied to the clamping screw will be insufficient and this will result in the screw becoming loose. For these reasons, NTK suggests that the clamping screw be replaced periodically.

④ Number of corners at which the tip can be used

The insert has a rectangular shape with 2 cutting edges. When the depth of cut is small or the amount of wear is not great, it may be possible to use four corners by mounting the insert in an opposite handed holder after it has been used for machining with the initial two corners.

⑤ Special products

Please consult NTK if you desire products with special cutter diameters or shank sizes that are not usually kept in stock.

⑥ Examples from actual users

Comparative data on the number of machining operations and surface quality

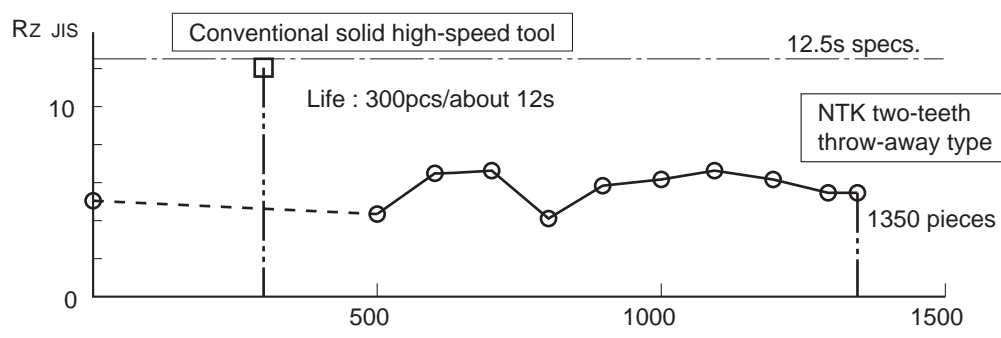

• Straight Shank

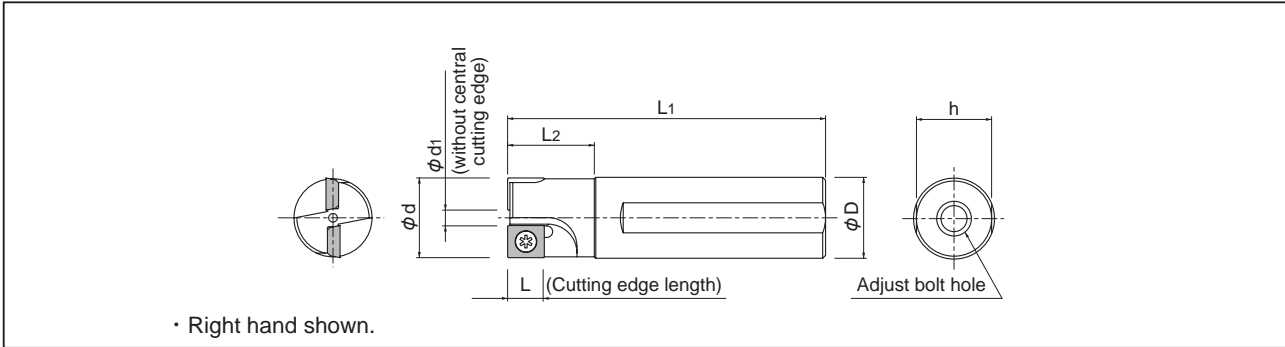

Item-No.	Stock	Dimensions (mm)							Adjust bolt	Insert
		ϕd	L1	L2	L	ϕd_1	ϕD	h		
RCL 140D2 ^{R/L} .021	○	14	55	15	(6)	($\phi 4$)	14	13	M6 × 20L	CLH050□CFN
120D2 ^{R/L} .050	○	12	60	15	(5)	($\phi 3$)	12	11	M4 × 20L	CLH0402C□□□-004

• Flanged Straight Shanks

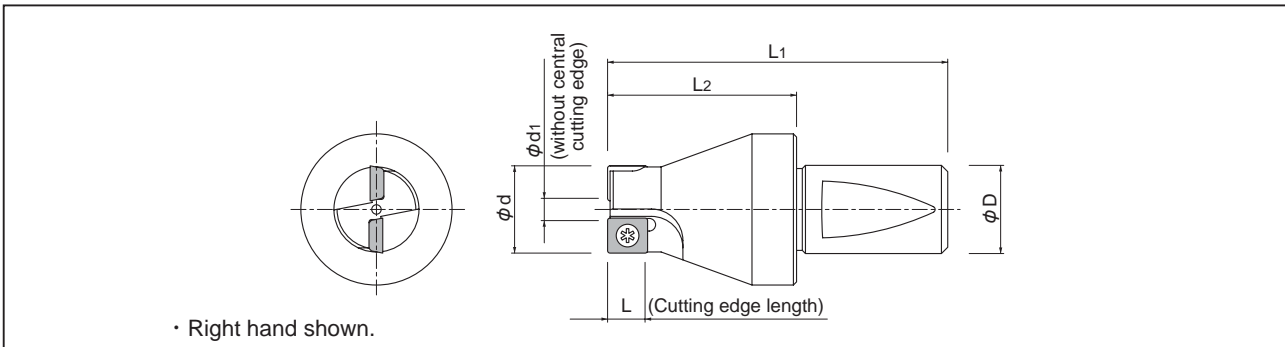

Item-No.	Stock	Dimensions (mm)							Insert
		ϕd	L1	L2	L	d1	ϕD		
RCL 140Z2 ^{R/L} .020	○	14	54	30	6	($\phi 4$)	14	CLH050□CFN	

• Flanged Straight Shanks

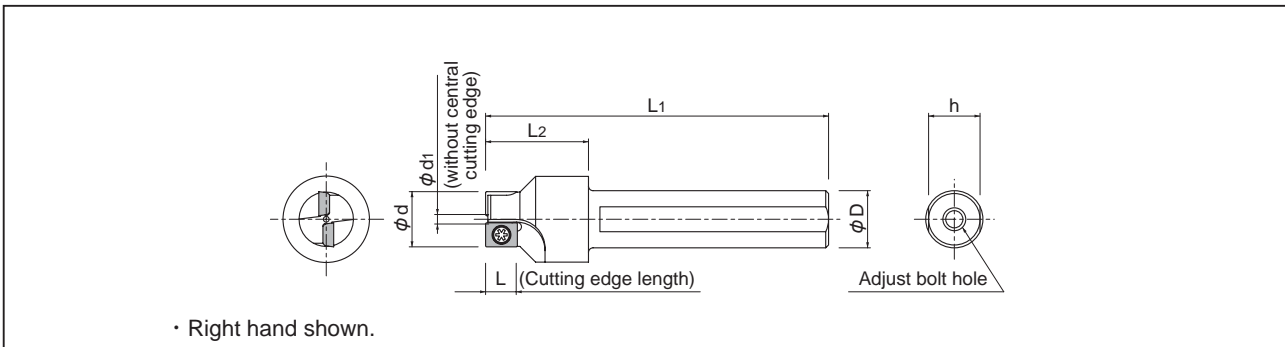

Item-No.	Stock	Dimensions (mm)							Adjust bolt	Insert
		ϕd	L1	L2	L	ϕd_1	ϕD	h		
RCL 100D2 ^{R/L} .066	○	10	60	18	(5)	($\phi 3$)	10	9.5	M4 × 20L	CLH0402C□□□-035

● Straight Shank

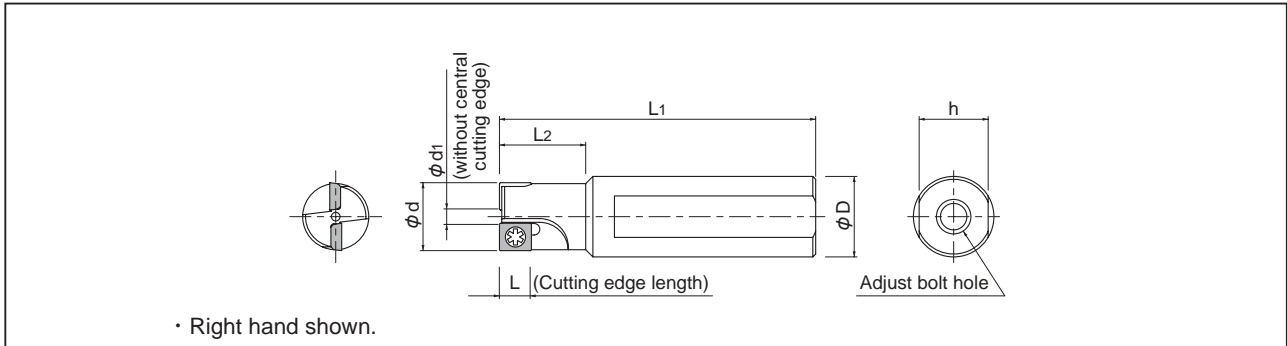

Item-No.	Stock	Dimensions (mm)							Adjust bolt	Insert
		ϕd	L_1	L_2	L	ϕd_1	ϕD	h		
RCL 120D2 ^R /L059	○	12	55	15	(5)	($\phi 3$)	14	13	M6 × 20L	CLH04

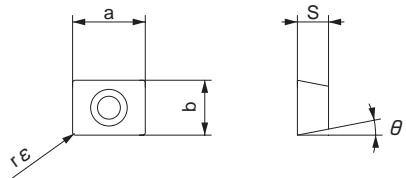

● Insert



Item-No.	Grade ZM3	Dimensions (mm)				
		a	b	s	θ	$r\epsilon$
CLH 0502CFN 0504CFN 0402CFN-004 0402CTNB004 0402CFN-035 0402CTNB035	○	6.35	5.56	2.18	11°	0.2
	○					0.4
	○	5.56	4.76	1.88	7°	0.2
	○					0.2
	○	5.56	4.2	1.88	7°	0.2
	○					0.2

Note) FN : Sharp edge TNB : T00525

● Parts

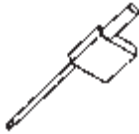
Parts	Clamping screw	Wrench	
		(A)	(B)
Toolholder			
RCL 140D2 ^R /L021 140Z2 ^R /L020 120D2 ^R /L050 120D2 ^R /L059 100D2 ^R /L066	FSI01-2.5 × 5	(A)	RLR-15S
	FSI04-2.0 × 4.3	(B)	T-06