

MODULHARD'ANDREA

Tapping chuck holders Gewindeschneidspannfutter Adaptadores para roscar Adaptateurs de taraudage Adattatori di maschiatura

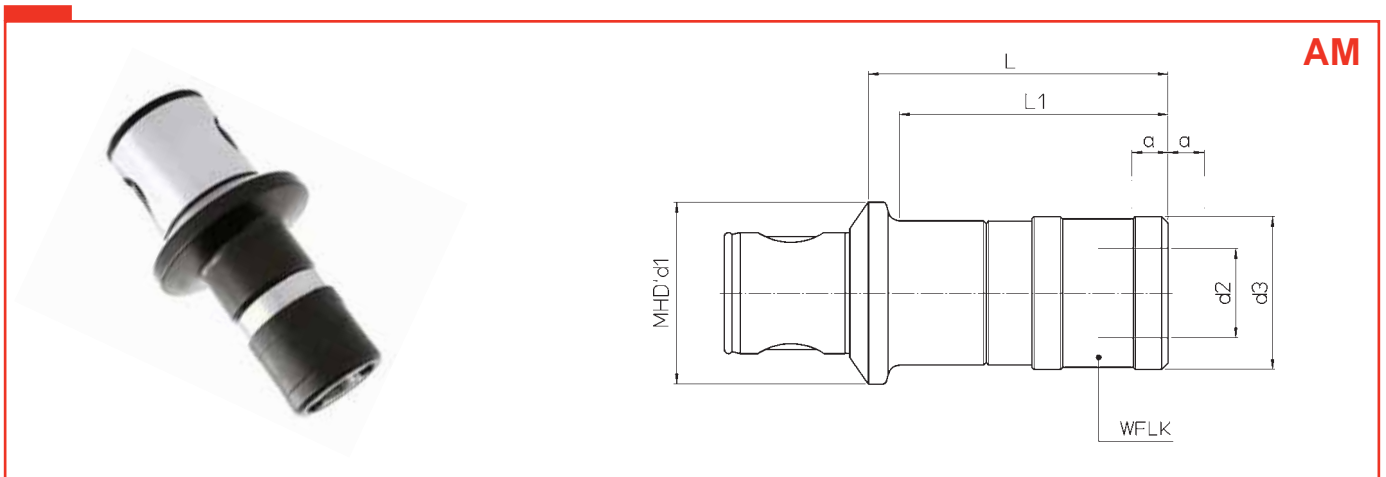

REF.	CODE	MHD' d ₁	WFLK	Capacity	L	L ₁	d ₂	d ₃	a	kg
AM 50/M3-12	65 65 050 0010 0	50	WFLK 115B/A 308	M 3 ~ 12	72	60	19	36	7.5	0.9
AM 50/M8-20	65 65 050 0020 0		WFLK 225B/A 308	M 8 ~ 20	106	–	31	53	12.5	1.2
AM 63/M3-12	65 65 063 0010 0	63	WFLK 115B/A 308	M 3 ~ 12	70	58	19	36	7.5	1
AM 63/M8-20	65 65 063 0020 0		WFLK 225B/A 308	M 8 ~ 20	104	93	31	53	12.5	1.3

Tapping chuck holders suitable for high production. Great axial adjustment both in compression and tension. There is the possibility of using quick change clutches with or without torque clutch.

Gewindeschneidspannfutter für hohe Beanspruchung in der Serienfertigung. Großer Längenausgleich auf Zug und Druck, mit Schnellwechselkupplung für Gewindebohrfutter mit oder ohne Drehmomentkupplung.

Adaptadores para roscar para alta producción. Gran compensación axial, sea en compresión que en tracción. Posibilidad de utilizar manguitos de cambio rápido con y sin limitación de par.

Adaptateurs de taraudage pour forte production. Grande compensation assiale en traction et compression, avec adaptateurs à changement rapide, pour porte-tarauds avec ou sans limiteur de couple.

Adattatori di maschiatura per forte produzione. Grande compensazione assiale sia in compressione sia in trazione. Possibilità di utilizzare bussole a cambio rapido, con e senza limitazione di coppia.

