



CLAMPING. SCREWING. LOCKING.
Plus Service Guarantee

*Certified according
to ISO 9001*

Zero-Point-Systems



Toggle Clamps
mechanical and pneumatic

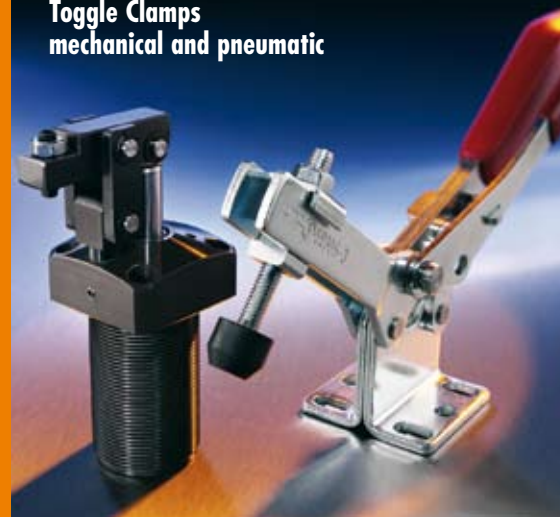

Standard Clamping
Elements

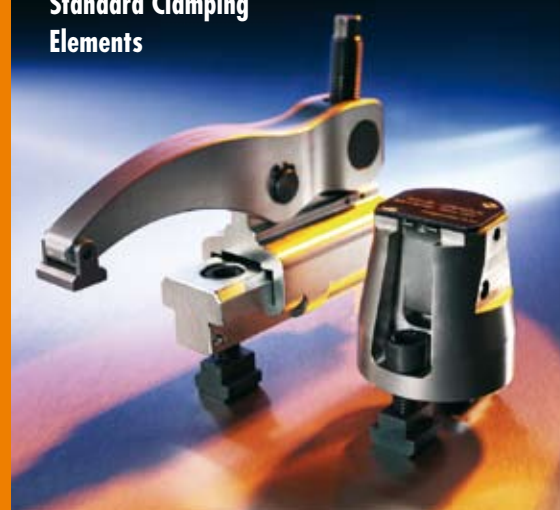

Hydraulic Clamping
Systems



Catalogue 2006/22GB



CLAMPING. SCREWING. LOCKING.
Plus Service Guarantee

**Multiple-Clamping
System**
**Pneumatic
Vice**



ANDREAS MAIER GmbH & Co. KG
Schloss- und Werkzeugfabrik

Home address: Waiblinger Straße 116
70734 Fellbach
Germany

Post address: Postfach 17 60
70707 Fellbach
Germany

E-mail: export@amf.de
Internet: www.amf.de
WAP: wap.amf.de

UK Sales Office:
Tony FORNSWORTH
UK Sales Manager

Phone: +44 (0) 1924 242 972
Fax: +44 (0) 1924 242 891
Mobile: +44 (0) 7976 942 421
E-mail: fornsworth@amf.de

Cat. order no. 444125 – € 1,50

All sales are subject to our terms of sales and delivery. All rights for creation, photos and text are reserved for editor AMF. Photo-mechanical or any other reproduction on expressed permission only.

OF -/0.5/-/3.5/03/2006 Printed in Germany

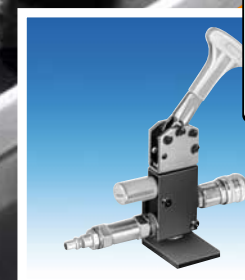
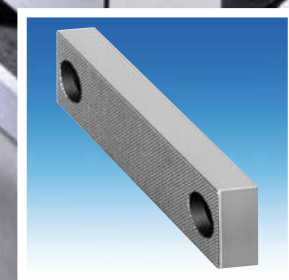

SERVICE-
AMF
GUARANTEE

ST
STANDART TOOLS
GROUP

Company history

- 1890:** Company founded by Andreas Maier as a lock manufacturer.
- 1920:** Production program extended to include spanners.
- 1928:** Production-line assembly of "Fellbach locks".
- 1951:** With the introduction of clamping elements, AMF diversified into the fields of workpiece and tool clamping.
- 1965:** Toggle clamps extend the AMF product range. AMF catalogues are now published in ten languages.
- 1975:** Hydraulic clamping marks further specialisation.
- 1982:** Clamping and fixture systems round off AMF competence in clamping.
- 1996:** Introduction of the AMF Team Organisation in all business sectors. Quality assurance certified to ISO 9001.
- 2002:** Introduction of the AMF Service Guarantee for all products.
- 2004:** Launching of our new Zero-Point-System "ZPS".
- 2005:** Launching of the Positioning System for Laser Marking.



Hans-Günther Maier
Managing Director
ANDREAS MAIER
GmbH & Co. KG

G. G. Maier

Dear Customers,

Since 1890, the name AMF has stood for reliability and the highest quality. Today our product range comprises more than 5000 articles in the sectors clamping, hand tools, and locks. That makes us a leading European manufacturer.

Outstanding products are only one side of the coin. For us, it is just as important to provide our customers with perfect service, day in and day out. We laid the foundations for this in recent years with our modern Team Organisation. The service from your partner at AMF will be quick, direct, and competent.

Our exceptional service has a name: the AMF Service Guarantee. It offers you five significant advantages – see them for yourself on this page.

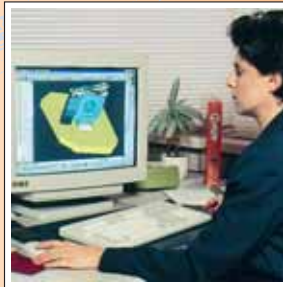



AMF Service Guarantee

We offer you confidence – five ways – in every aspect of our products. At AMF, the service is right too. You can rely on us. Guaranteed!

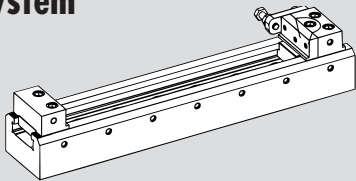
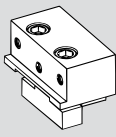
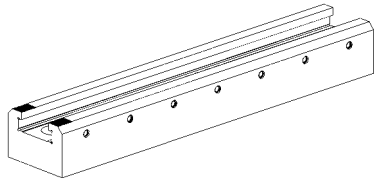
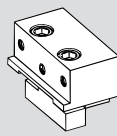
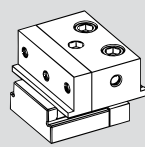
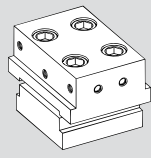
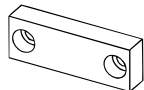
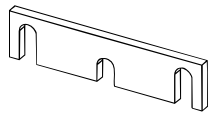
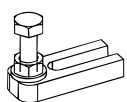
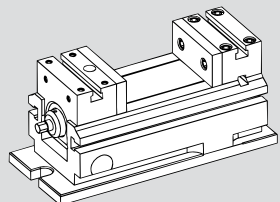
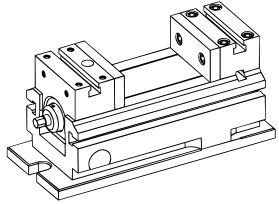
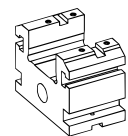

- 1 Real technical advice**
Many tasks and a multitude of solutions. From AMF Professional Products you can find the right way to solve your problem – fast and reliably – either at your local dealer or with the help of the specialist in our team. Just call us!
- 2 Short delivery times**
From the AMF finished-product stores with over 5.000 articles, we can supply 98 % of orders from stock. And you can be sure that every stock article ordered is despatched the same day.
- 3 Certified quality**
AMF stands for painstaking production in our own works. We have followed this tradition since 1890 – today, of course, with a modern quality assurance system to ISO 9001.
- 4 Warranty**
We believe in the high quality of our products. Complaints are dealt with quickly, unbureaucratically and generously – as far as possible, even well-beyond the guarantee period.
- 5 Individual development**
You cannot find the product you need? Talk to us; we will find the right solution for you – from a special version, right through to a completely new development.

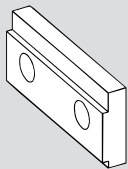
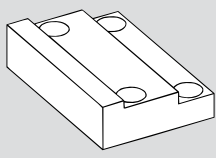
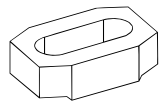
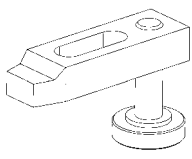
Multiple-Clamping System	... about Multiple-Clamping System			4-5	
	Base elements			6-7	
	Base jaws, Clamping jaws				8-11
	Gripping jaws, Accessories				12-13
Pneumatic Vice	... about Pneumatic Vice			14	
	Base elements and Modular carrier				15
	Gripping jaws				16-19
	Accessories				20

Clamping system for the multiple clamping of small items in series production on state-of-the-art NC and CNC tools used for drilling, milling, grinding and electrical discharge machining.

Benefits at a glance:

- High-precision multiple clamping device
- Hardened steel (60 HRC)
- Up to 16 clamping positions per work piece
- Simple and precise adjustment of clamping jaws thanks to serrated contact surfaces
- Positioning increments of 1 mm
- Scale at basic module and reference mark at the clamping jaws allow the positioning without measuring and test equipment
- Positive-fit attachment of clamping jaws
- Single-bolt clamping per clamping position
- 50 mm, 80 mm and 120 mm jaw width
- Modular design: Set-up for one or multiple Work pieces as required
- Work piece supports integrated in clamping jaws
- For use on machine tables, devices and quick-change systems

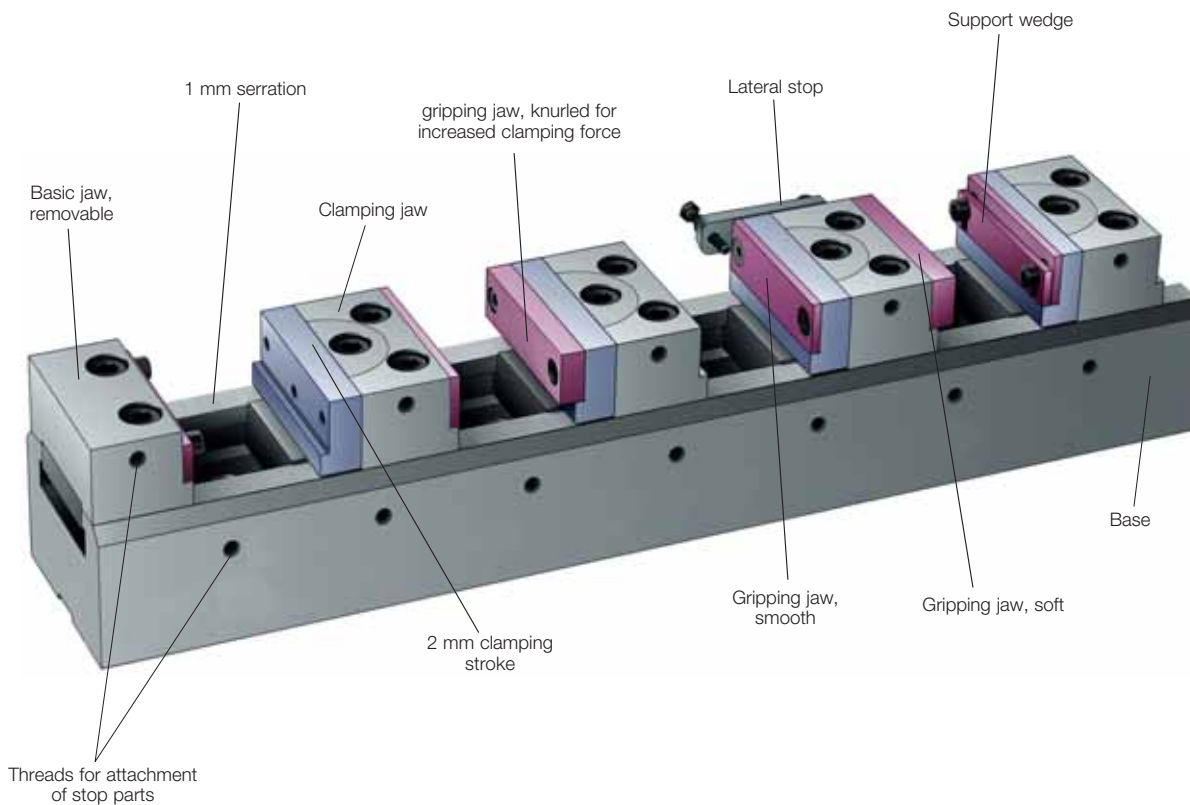

Work-piece quantities for multiple clamping system:

Size	Length [mm]	Work-piece quantity															
		1	2	3	4	5	6	7	8	9	10	11	12	13	14	15	16
50	250	191	78	41	22	11											
	320	261	113	64	39	25	15	8									
	500	441	203	124	84	61	45	34	25	18	13	9					
	600	541	253	157	109	81	61	48	38	30	23	18	14	10			
	700	591	278	174	122	91	70	56	44	35	28	22	18	14	10		
80	350	261	105	52	26	11											
	500	411	180	102	64	41	25	14									
	600	511	230	136	89	61	42	28	18	11							
	650	561	255	152	101	71	50	36	25	16							
	700	611	280	169	114	81	59	43	31	22	14						
120	500	381	158	83	46	24	9										
	600	481	208	117	71	44	26	13									
	700	581	258	150	96	64	42	27	15								

Clamping force and torque:

Jaw width 50 mm - max. clamping force 12 kN

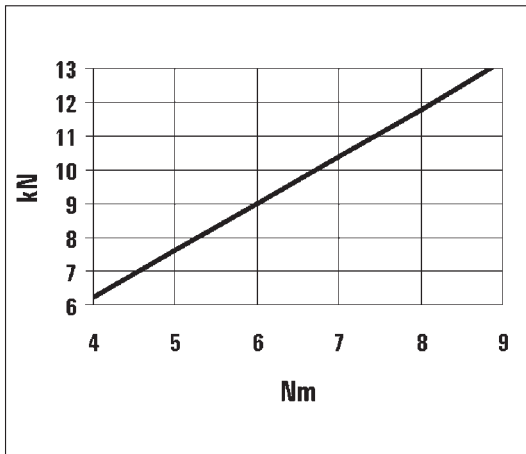

Jaw width 80 and 120 mm - max. clamping force 25 kN

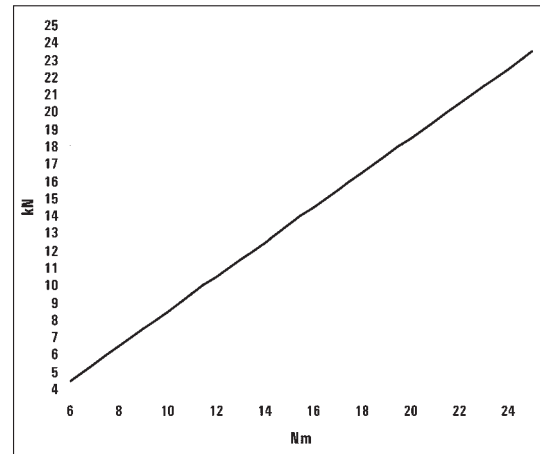

Torques for grade 12.9 mounting bolts:

Jaw width	Attachment of basic jaws	Attachment of clamping jaws
50 mm	2 x M 6, max. 25 Nm	2 x M 6, max. 20 Nm
80 mm	2 x M10, max. 30 Nm	2 x M10, max. 30 Nm
120 mm	4 x M10, max. 30 Nm	2 x M10, max. 30 Nm

Example for rationalization calculation:

Machine	Table 400 x 500 mm	
Machine hourly rate	€ 80,-/h	
Work piece	Centering, drilling, counter-sinking, tapping	
Work plan	Vice – 1 work piece	Multiple clamping system – 5 work pieces
Insertion and clamping of work piece	10 sec.	5 x 10 sec. = 50 sec.
Closing of protective cover, program start	10 sec.	10 sec. = 10 sec.
4 x processing	60 sec.	5 x 60 sec. = 300 sec.
4 x tool changes (chip-to-chip)	60 sec.	60 sec. = 60 sec.
Opening of protective cover	10 sec.	10 sec. = 10 sec.
Cleaning of vice and work piece	20 sec.	5 x 20 sec. = 100 sec.
	170 sec.	530 sec.
Bearbeitungskosten	€ 3.75 / work piece	€ 2.35 / work piece This means a cost reduction of € 1.40 / work piece or 37%

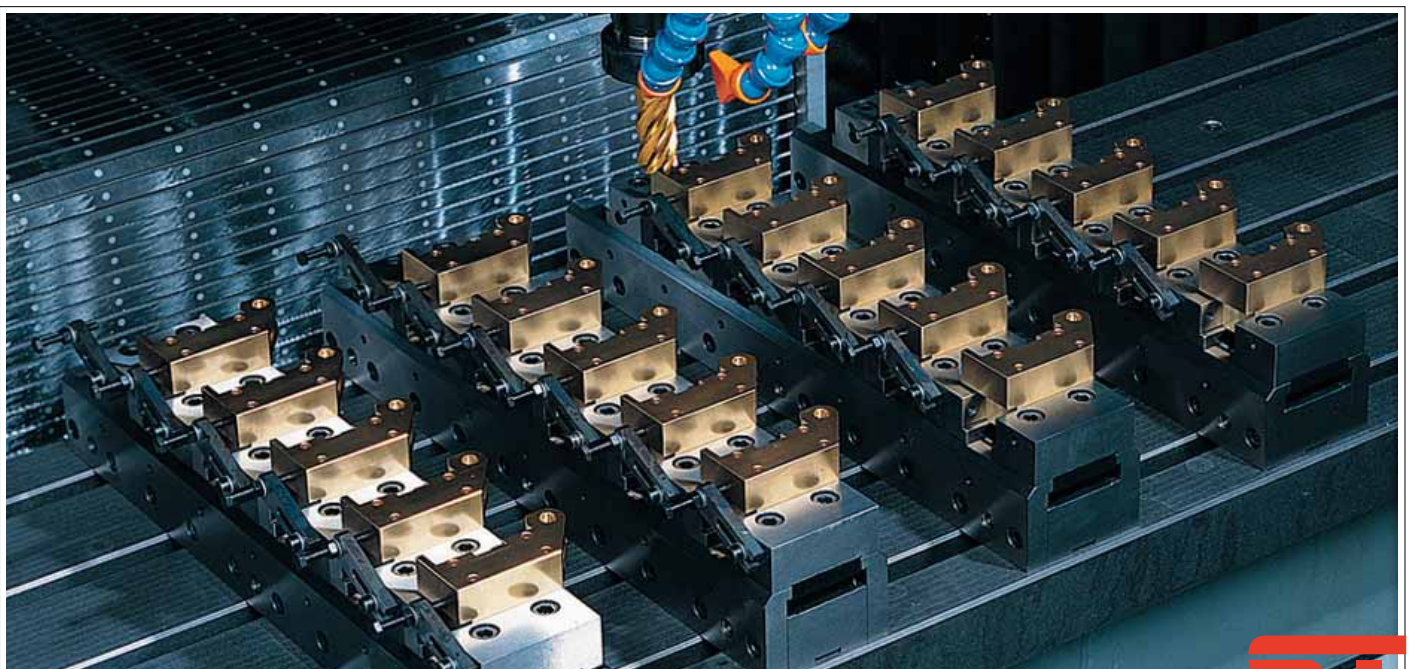

No. 6371G-50 Base element
Jaw width 50 mm
 Bore spacing 40 mm.
 Hardened 60 HRC, 1 mm splines.
 Fits all AMF pitch systems:
 40 mm pitch, M12, ø16 F7.

Order no.	Article no.	Length [mm]	Clamping force [kN]	kg
304873	6371G-50-250-040	250	12	3.3
304923	6371G-50-320-040	320		4.2
304899	6371G-50-500-040	500		6.6
304949	6371G-50-600-040	600	12	8.0
304915	6371G-50-650-040	650		8.7
304964	6371G-50-700-040	700		9.3

No. 6371G-80 Base element
Jaw width 80 mm
 Bore spacing 40 mm.
 Hardened 60 HRC, 1 mm splines.
 Fits all AMF pitch systems:
 40 mm pitch, M12, ø16 F7.

Order no.	Article no.	Length [mm]	Clamping force [kN]	kg
304774	6371G-80-350-040	350	25	11.1
304824	6371G-80-500-040	500		15.8
304790	6371G-80-600-040	600		18.9
304840	6371G-80-650-040	650	25	20.6
304816	6371G-80-700-040	700		22.1

No. 6371G-80 Base element
Jaw width 80 mm
 Bore spacing 50 mm.
 Hardened 60 HRC, 1 mm splines.
 Fits all AMF pitch systems:
 50 mm pitch, M16, ø22 F7.

Order no.	Article no.	Length [mm]	Clamping force [kN]	kg
304766	6371G-80-350-050	350	25	10.7
304782	6371G-80-500-050	500		15.5
304733	6371G-80-600-050	600		18.6
304758	6371G-80-650-050	650	25	20.0
304808	6371G-80-700-050	700		21.7

No. 6371G-120 Base element
Jaw width 120 mm
 Bore spacing 50 mm.
 Hardened 60 HRC, 1 mm splines.
 Fits all AMF pitch systems:
 50 mm pitch, M16, ø22 F7.

Order no.	Article no.	Length [mm]	Clamping force [kN]	kg
304865	6371G-120-500-050	500	25	13.0
304881	6371G-120-600-050	600		15.9
304907	6371G-120-700-050	700		18.5



Technical data base element No. 6371G

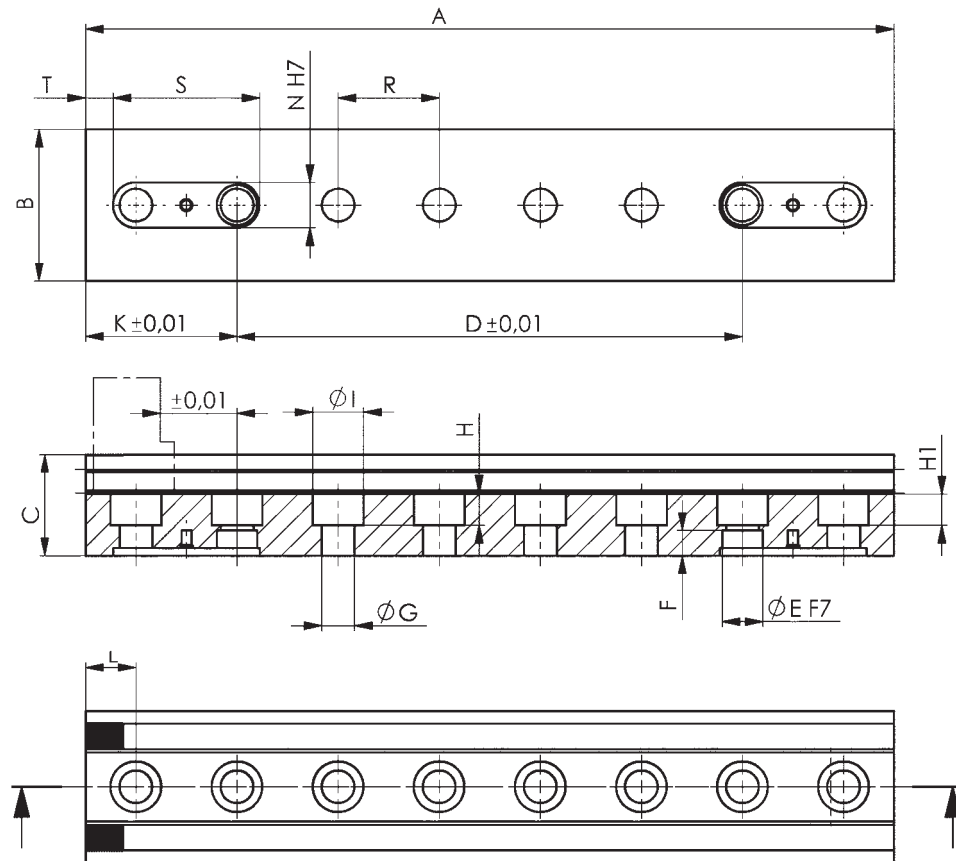

Jaw width 50 mm, bore spacing 40 mm

Article no.	A	B	C	D	E	F	G	H	H1	I	K	L	N	R	S	T
6371G-50-250-040	250	60	40	200	16	10	13	12.5	12.5	20	25	25	18	40	58	16
6371G-50-320-040	320	60	40	200	16	10	13	12.5	12.5	20	60	20	18	40	58	11
6371G-50-500-040	500	60	40	400	16	10	13	12.5	12.5	20	30	30	18	40	58	21
6371G-50-600-040	600	60	40	400	16	10	13	12.5	12.5	20	100	20	18	40	58	51
6371G-50-650-040	650	60	40	400	16	10	13	12.5	12.5	20	125	45	18	40	58	76
6371G-50-700-040	700	60	40	400	16	10	13	12.5	12.5	20	150	30	18	40	58	101

Jaw width 80 mm, bore spacing 40 mm

Article no.	A	B	C	D	E	F	G	H	H1	I	K	L	N	R	S	T
6371G-80-350-040	350	90	60	200	16	10	13	12.5	12.5	20	75	35	18	40	58	26
6371G-80-500-040	500	90	60	400	16	10	13	12.5	12.5	20	30	30	18	40	58	21
6371G-80-600-040	600	90	60	400	16	10	13	12.5	12.5	20	100	20	18	40	58	51
6371G-80-650-040	650	90	60	400	16	10	13	12.5	12.5	20	125	45	18	40	58	76
6371G-80-700-040	700	90	60	400	16	10	13	12.5	12.5	20	150	30	18	40	58	101

Jaw width 80 mm, bore spacing 50 mm

Article no.	A	B	C	D	E	F	G	H	H1	I	K	L	N	R	S	T
6371G-80-350-050	350	90	60	200	22	13	17	17	17	26	75	25	18	50	68	16
6371G-80-500-050	500	90	60	400	22	13	17	17	17	26	75	25	18	50	68	16
6371G-80-600-050	600	90	60	400	22	13	17	17	17	26	100	50	18	50	68	41
6371G-80-650-050	650	90	60	400	22	13	17	17	17	26	125	25	18	50	68	66
6371G-80-700-050	700	90	60	400	22	13	17	17	17	26	150	50	18	50	68	91

Jaw width 120 mm, bore spacing 50 mm

Article no.	A	B	C	D	E	F	G	H	H1	I	K	L	N	R	S	T
6371G-120-500-050	500	105	45	250	22	13	17	17	4x10	25	125	25	18	50	68	16
6371G-120-600-050	600	105	45	300	22	13	17	17	4x10	25	150	50	18	50	68	41
6371G-120-700-050	700	105	45	300	22	13	17	17	4x10	25	200	50	18	50	68	91

No. 6371

Base jaw, standard

First stop on base element, for 50, 80 or 120 mm jaw width. Hardened 60 HRC.



Order no.	Article no.	g
265793	6371-4101-50	226
266809	6371-4111-80	880
304980	6371-12001-120	2300

Dimensions:

Article no.	A	B	C	(D)	E	F	G	H	J	K	L	M	N
6371-4101-50	49	20.0	17	28	24.7	3.3	12.4	8	8.5	18.5	5.5	3xM5	2xM6
6371-4111-80	78	32.2	22	42	38.0	4.0	19.0	8	11.0	31.5	6.0	3xM6	2xM6
6371-12001-120	120	42.2	32	54	50.0	4.0	25.0	8	16.0	45.0	6.0	3xM6	2xM6

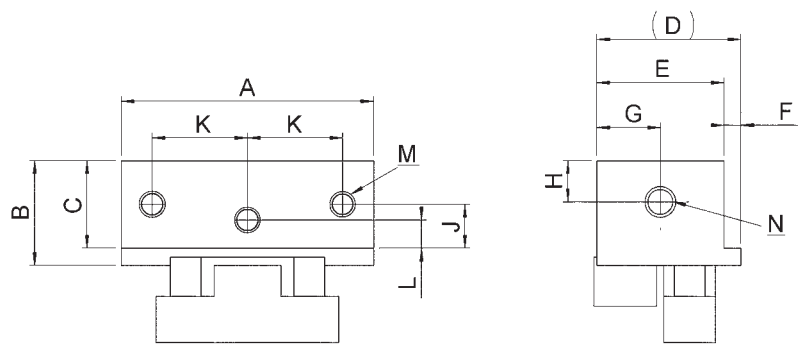

No. 6371

Base jaw, deep

First stop on base element, for 50 or 80 mm jaw width. Hardened 60 HRC.



Order no.	Article no.	g
290635	6371-4120-50	230
290650	6371-4121-80	900

Dimensions:

Article no.	A	B	C	(D)	E	F	G	H	J	K	L	M	N
6371-4120-50	49	20.0	17	31	24.7	6.3	12.4	8	8.5	18.5	5.5	3xM5	2xM6
6371-4121-80	78	32.2	22	46	38.0	8.0	19.0	8	11.0	31.5	6.0	3xM6	2xM6

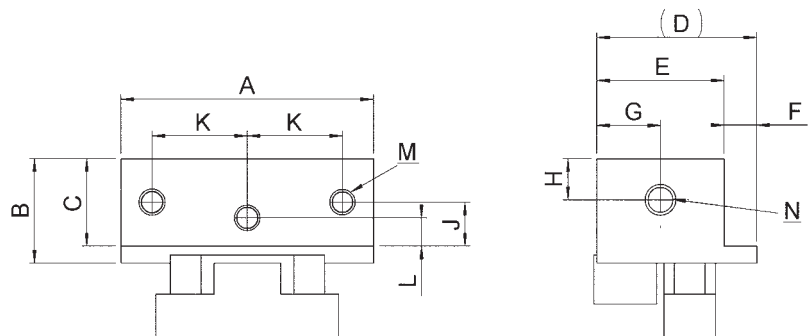

No. 6371

Clamping jaw, without step

First stop on base element, for 50 or 80 mm jaw width.
Hardened 60 HRC.



Order no.	Article no.	g
304931	6371-50105-50	340
304956	6371-80107-80	1330

Dimensions:

Article no.	A	B	D	F	G	H	J	K	L	M	N
6371-50105-50	49	20.0	32	-	0	8	8.5	18.5	11.5	6xM5	2xM6
6370-80107-80	78	32.2	50	23	9	8	11.0	31.5	16.0	8xM6	4xM6

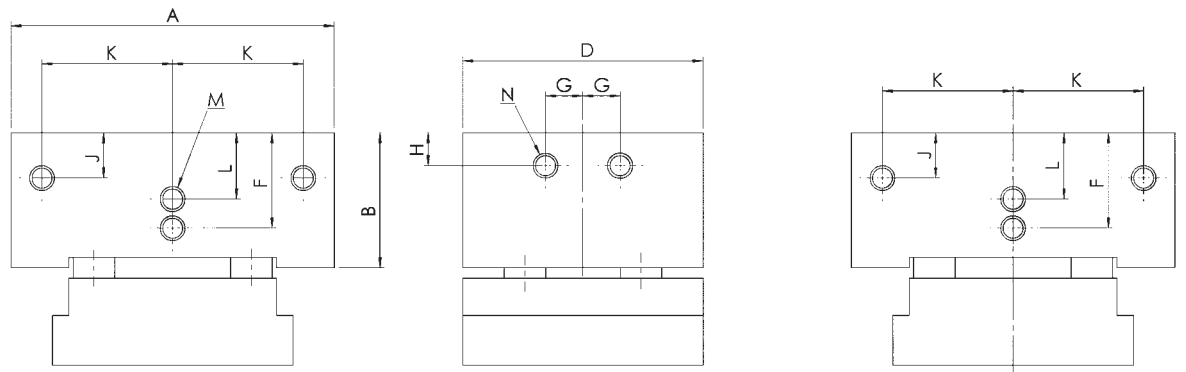

No. 6371

Central jaw for clamping from two sides.

For 50 or 80 mm jaw width.
Hardened 60 HRC.



Order no.	Article no.	g
300905	6371-4112-50	370
300921	6371-4300-80	1424

Dimensions:

Article no.	A	B	C	(D)	E	F	G	H	J	K	L	M	N
6371-4112-50	47	20.0	17	40	33.4	3.3	4.5	8	8.5	18.5	5.5	6xM5	4xM6
6371-4300-80	78	32.2	22	58	50.0	4.0	9.0	8	11.0	31.5	6.0	6xM6	4xM6

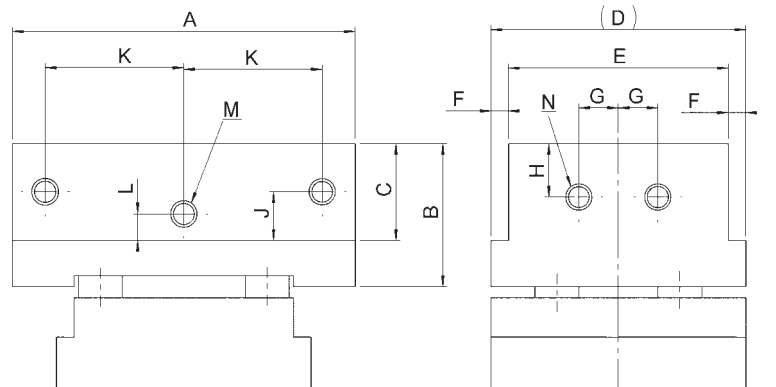

No. 6371

Clamping jaw, standard

For 50, 80 or 120 mm jaw width, with 1 mm positioning increments. Hardened 60 HRC. With one clamping bolt and two mounting bolts.



Order no.	Article no.	Clamping force [kN]	Clamping stroke [mm]	g
265835	6371-4102-50	12	2	373
266825	6371-4110-80	25		1446
305003	6371-12002-120	25		2900

Dimensions:

Article no.	A	B	C	(D)	E	F	G	H	J	K	L	M	N	T	U	V
6371-4102-50	49	20.0	17	40	33.7	3	12.4	8	8.5	18.5	5.5	6xM5	2xM6	3.3	5	28
6371-4110-80	78	32.2	22	60	52.0	4	19.0	8	11.0	31.5	6.0	6xM6	2xM6	4.0	7	42
6371-12002-120	120	42.2	32	72	64.0	4	25.0	8	16.0	45.0	6.0	6xM6	2xM6	4.0	7	54

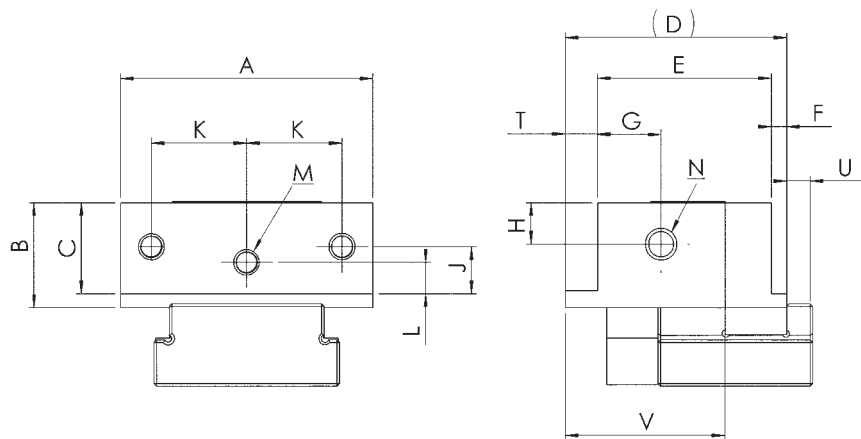

No. 6371

Clamping jaw, deep

For 50 or 80 mm jaw width, with 1 mm positioning increments. Hardened 60 HRC. With one clamping bolt and two mounting bolts.



Order no.	Article no.	Clamping force [kN]	Clamping stroke [mm]	g
300863	6371-4109-50	12	2	390
300889	6371-4119-80	25		1430

Dimensions:

Article no.	A	B	C	(D)	E	F	G	H	J	K	L	M	N	T	U	V
6371-4109-50	49	20.0	17	43	30.7	6	12.4	8	8.5	18.5	5.5	6xM5	2xM6	6.3	5	31
6371-4119-80	78	32.2	22	64	48.0	8	19.0	8	11.0	31.5	6.0	6xM6	2xM6	8.0	7	46

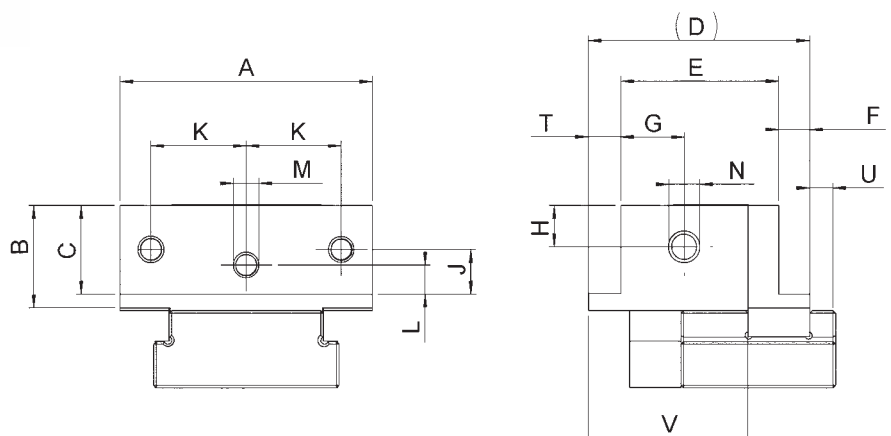

No. 6371

Clamping jaw, without step

For 50 or 80 mm jaw width, with 1 mm positioning increments. Hardened 60 HRC. With one clamping bolt and two mounting bolts.



Order no.	Article no.	Clamping force [kN]	Clamping stroke [mm]	g
304972	6371-50101-50	12	2	370
304998	6371-80101-80	25		1400

Dimensions:

Article no.	A	B	D	G	H	J	K	L	M	N	T	V
6371-50101-50	49	20.0	36.5	13.0	8	8.5	18.5	11.5	7xM5	2xM6	-	17.5
6371-80101-80	78	32.2	55.5	20.5	8	11.0	31.5	16.0	8xM6	2xM6	23	23.0

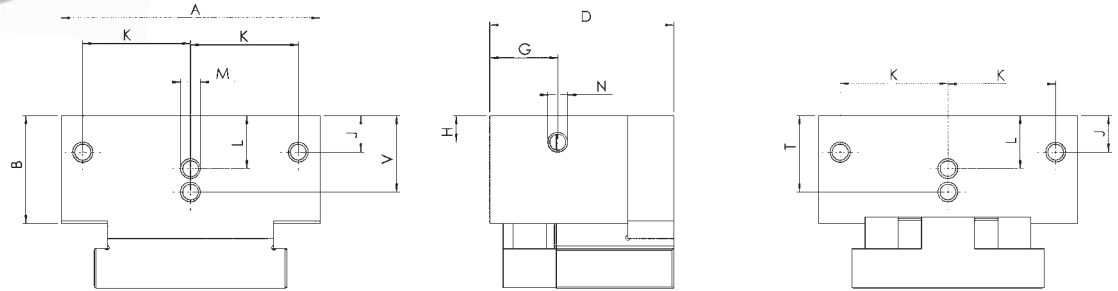

No. 6371

Clamping jaw, with crescent

For 50 or 80 mm jaw width, with 1 mm positioning increments. Hardened 60 HRC. With one clamping bolt for size 50 or two bolts for size 80, and with two mounting bolts.



Jaw width 50 mm



Jaw width 80 mm

Order no.	Article no.	Clamping force [kN]	Clamping stroke [mm]	g
305011	6371-50110-50	12	1.4	280
305037	6371-80110-80	25		1000

Dimensions:

Article no.	A	B	C	D	G	H	J	L	M	N	T
6371-50110-50	49	23.0	28	30.5	15.3	8	-	-	-	2xM6	12
6371-80110-80	82	32.2	2x28	46.0	23.0	8	16	25	4xM6	2xM6	16

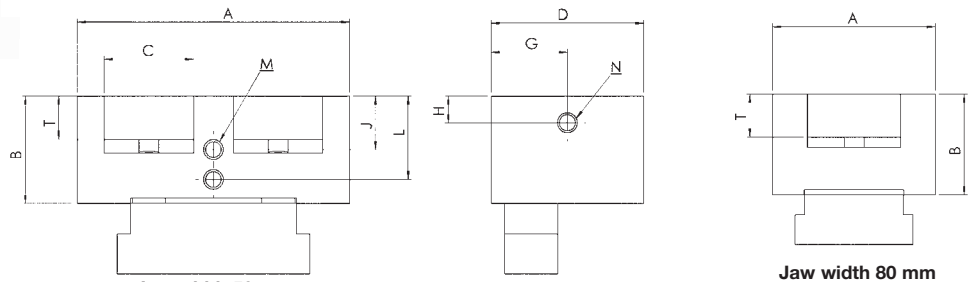

Application example, jaw width 80 mm:

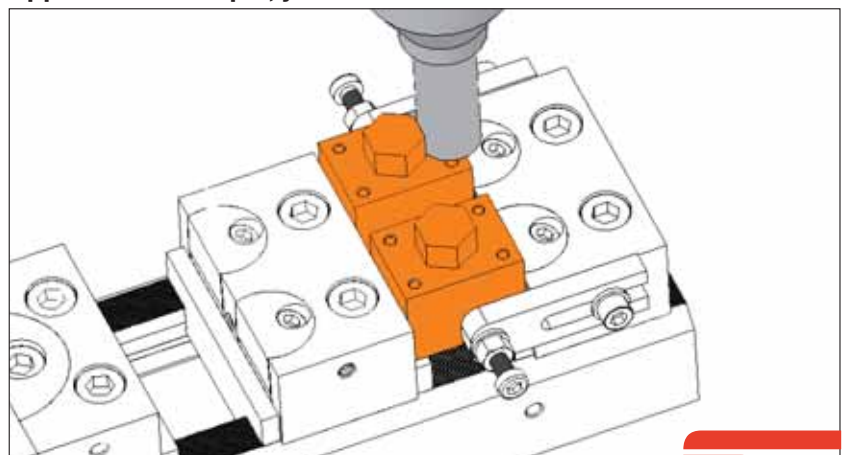

No. 6371 **Gripping jaw, smooth**
Hardened 60 HRC.



Order no.	Article no.	for jaw width	A	B	C	g
300988 301002	6371-4107-50-04 6371-4108-50-09	50	49	4 9	17	23 51
301028 301044	6371-4117-80-04 6371-4118-80-11	80	78	4 11	22	49 135
304857	6371-12024-120-04	120	120	4	32	115

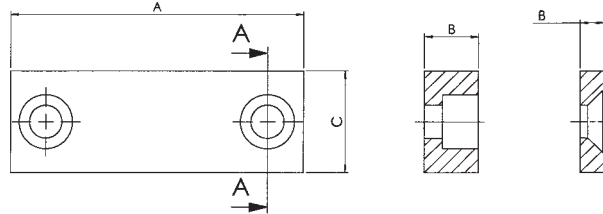

No. 6371 **Gripping jaw, smooth**
Not hardened, for individual processing.



Order no.	Article no.	for jaw width	A	B	C	g
266569 266585	6371-4103-50-09 6371-4104-50-12	50	49	9 12	17	51 67
266841 266866	6371-4113-80-11 6371-4114-80-18	80	78	11 18	22	133 217
304832	6371-12018-120-15	120	120	15	32	430

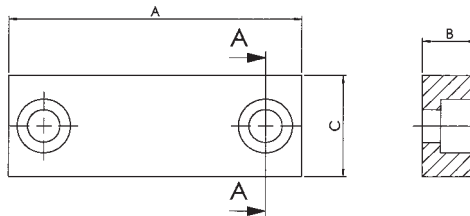

No. 6371 **Gripping jaw, knurled**
Hardened 60 HRC.



Order no.	Article no.	for jaw width	A	B	C	g
300947 266601	6371-4105-50-04 6371-4106-50-09	50	49	4 9	17	21 51
300962 266882	6371-4115-80-04 6371-4116-80-11	80	78	4 11	22	46 133
305029	6371-12025-120-04	120	120	4	32	110

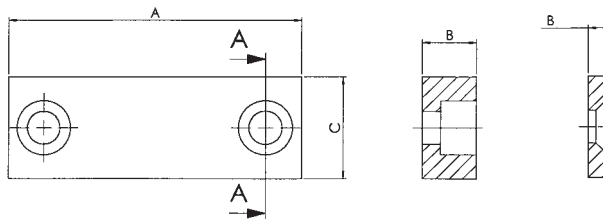

No. 6371 **Gripping jaw, with claws**
Hardened 60 HRC.
Clamping edge height only 2 mm.



Order no.	Article no.	for jaw width	Screw DIN 7984	A	B	C	H ±0.02	g
305086	6371-100-50-12	50	M5x20	49	17	15	70	
305094	6371-100-80-12	80	M6x20	78	22	20	150	
305102	6371-100-120-12	120	M6x20	120	32	30	350	

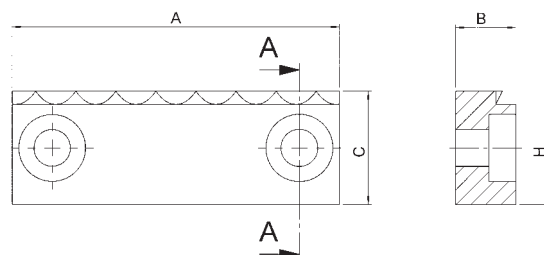

No. 6371 Support wedge



Form A

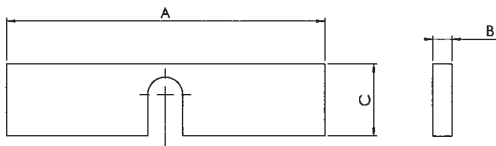

Form B

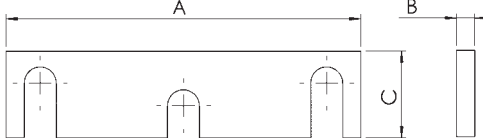

Order no.	Article no.	Forme	A	B	C	g
-----------	-------------	-------	---	---	---	---

for jaw width 50 mm

266627	6371-4201-50-011	A	49	3	11	11
266643	6371-4202-50-012				12	12
266668	6371-4203-50-013				13	13
266684	6371-4204-50-014	A	49	3	14	16
266700	6371-4205-50-015				15	16
266726	6371-4206-50-016				16	17

for jaw width 80 mm

301069	6371-4351-80-012	A	78	4	12	27
300871	6371-4352-80-013				13	30
300897	6371-4353-80-014				14	33
300913	6371-4354-80-015				15	34
266908	6371-4355-80-016	B	78	4	16	35
266577	6371-4356-80-017				17	36
266593	6371-4357-80-018				18	37
266619	6371-4358-80-019				19	40
266635	6371-4359-80-020				20	43
266650	6371-4360-80-021				21	46

for jaw width 120 mm

305045	6371-1216-120-016	A	120	4	16	580
305060	6371-1220-120-020				20	730
305052	6371-1224-120-024	B	120	4	24	790
305078	6371-1228-120-028				28	950

No. 6371 Lateral stop for base, central and clamping jaw.



Order no.	Article no.	B	H	L	M	g
266742	6371-4220-50	16	7	40	6	35
266676	6371-4380-80	18	8	60		69
295006	6371-4380-1-80	18	8	78		80

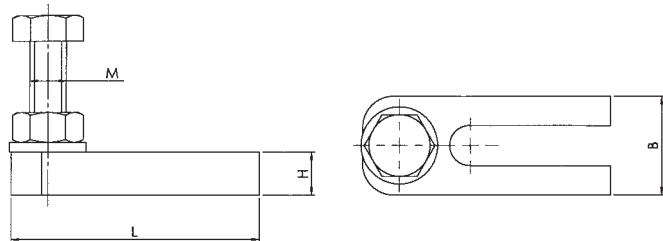

No. 6371 Chip guard



Order no.	Article no.	Fixation	g
300970	6371-4222-50	right	19
300996	6371-4391-80		43
300939	6371-4221-50	left	19
300954	6371-4390-80		43

No. 6371 T-nut

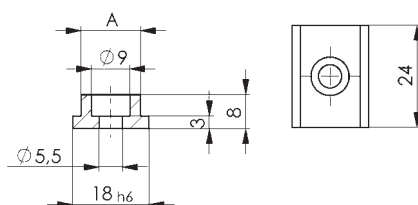

Order no.	Article no.	A	g
301010	6371-9010-10	10	16
301036	6371-9012-12	12	17
301051	6371-9014-14	14	18
301077	6371-9018-18	18	23

Benefits at a glance:

- The pneumatic vice is specifically designed for the machining of single and series items that require quick and precise clamping.
- The pneumatic operation significantly reduces the clamping time.
- The clamping force is adjustable to different work-piece requirements.
- All supports and guides are hardened (55-60 HRC) and ground. The supports are manufactured to a height tolerance of ± 0.01 mm.
- Jaws are case-hardened (60 HRC)
- 4 slots facilitate the simple attachment of locators, gauges and special jaws.
- Jaw widths of 70 to 200 mm
- Clamping forces of up to 70 kN at 6 bar

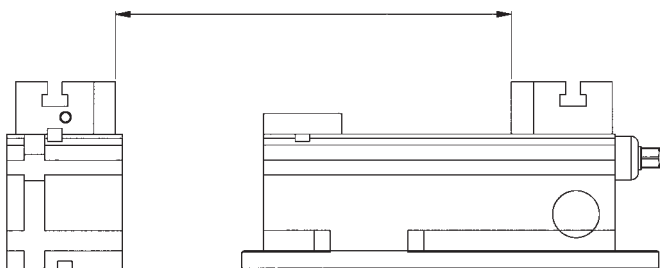
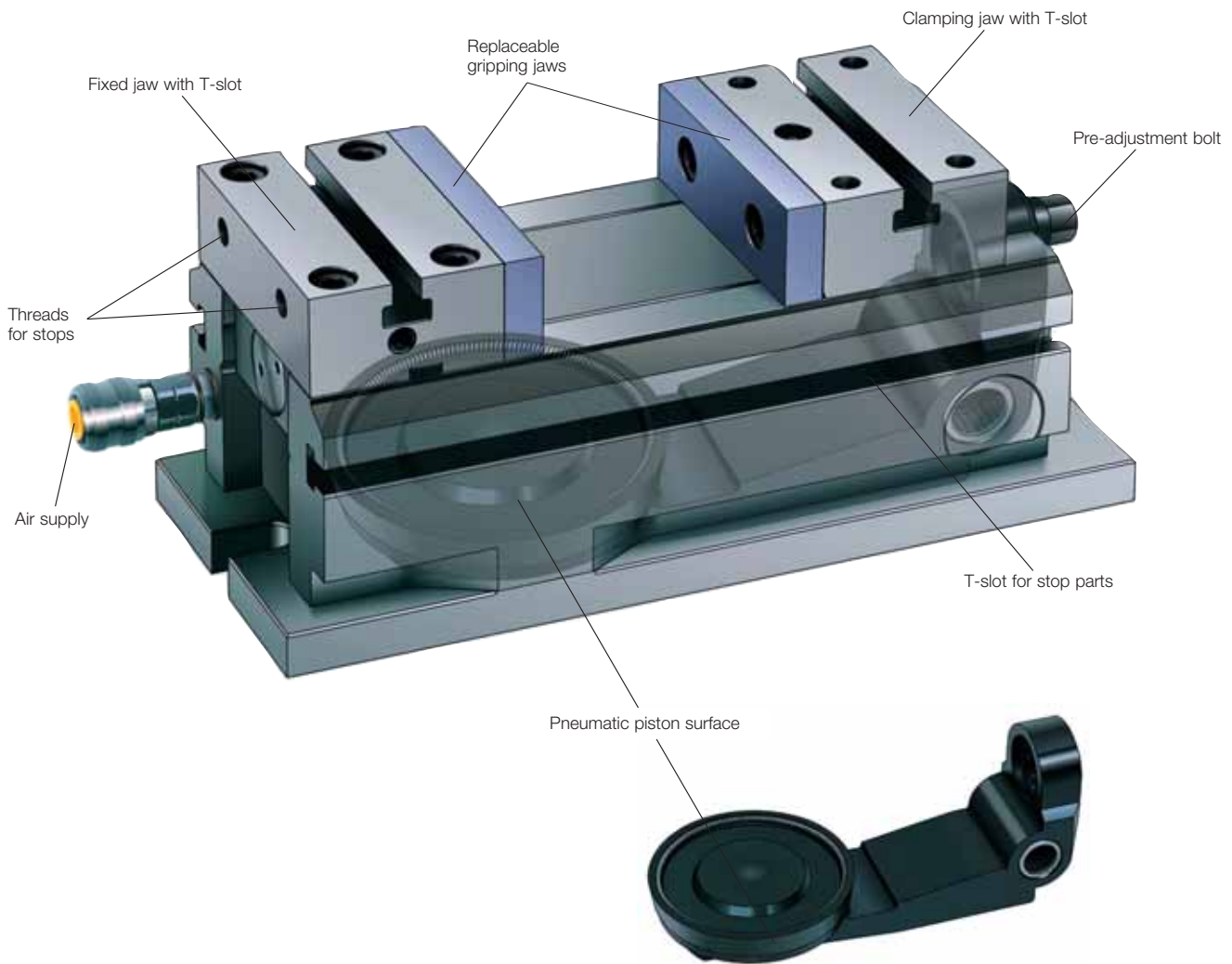

Vice with modular carrier

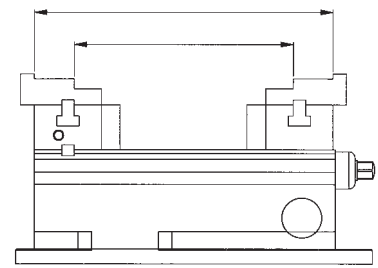

Vice with stepped gripping jaw

Specifications subject to change

No. 6372

Base element

Hardened 56 HRC.
With 1 pair of gripping jaws, smooth,
hardened 60 HRC.

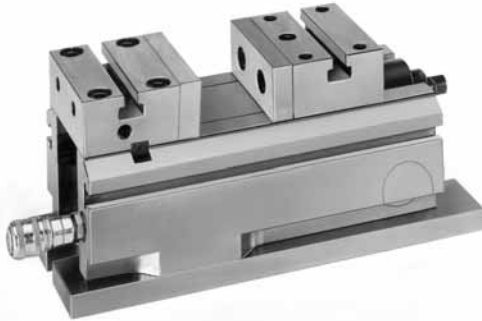

Order no.	Article no.	Jaw width A [mm]	Clamping force at 6 bar [kN]	kg
301085	6372-0700-E070	70	5	8.5
301101	6372-0900-E090	90	10	18
301127	6371-1002-E100	100	15	25
301143	6372-1150-E115	115	22	30
301168	6372-1301-E130	130	30	39
301184	6372-1600-E160	160	50	58
301200	6372-2000-E200	200	70	112

Dimensions:

Size A	B	C	D	E	F	G	H	I	Stroke K	L	M	N	O	P	SW
70	40	90	102	187	220	87	107	139	2.0	70	M 6	10.0	200	14	8
90	44	112	128	241	288	103	133	177	4.0	92	M 8	20.0	288	18	14
100	46	128	145	260	317	86	116	178	4.0	105	M10	20.0	277	18	14
115	60	140	145	290	340	112	142	206	3.2	105	M10	20.0	300	18	17
130	65	160	155	315	370	127	163	229	3.5	110	M10	20.0	330	18	17
160	80	196	160	368	403	164	200	272	4.0	115	M10	18.5	366	18	17
200	100	236	195	475	480	235	275	361	4.5	135	M12	20.0	440	18	17

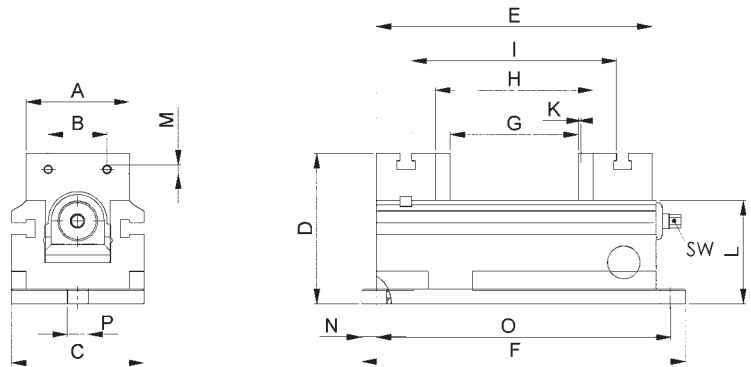

No. 6372

Modular carrier and support

Hardened 56 HRC.

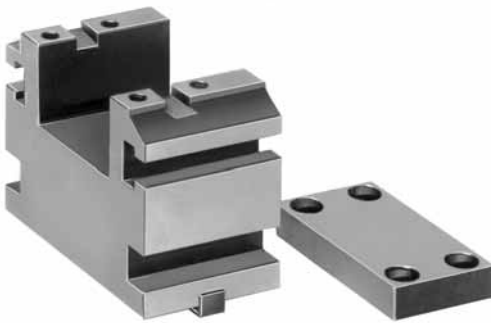

Order no.	Article no.	g
301242	6372-3013-E070	1742
301267	6372-3001-E090	4230
301283	6372-3002-E100	6460
301309	6372-3003-E115	7670
301341	6372-3005-E160	12420
301366	6372-3006-E200	24490

Dimensions:

Size A1	A	B	C	C1	D	D1	E	E1	F	F1	G	G1	L ±0.01	M	N
70	90	56	54	40	11	7.0	28.5	11	17	11.0	11	7	70	4	24
90	112	68	80	54	14	8.5	33.0	14	28	14.0	16	9	92	8	36
100	128	80	91	72	14	10.5	36.0	17	28	17.0	16	12	105	10	43
115	140	91	100	74	17	10.5	36.0	17	35	17.0	17	12	105	10	46
160	196	126	120	84	17	13.0	40.0	17	35	19.0	17	13	115	12	56
200	236	150	140	100	22	16.5	50.0	23	50	16.5	22	17	135	16	70

Modular carrier:

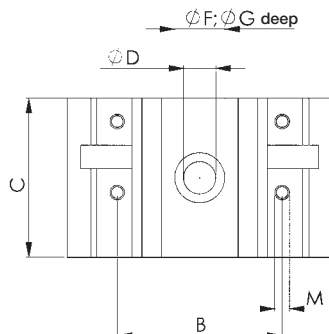
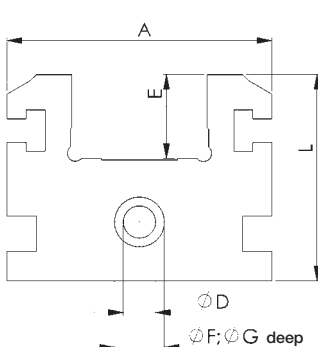

Support:

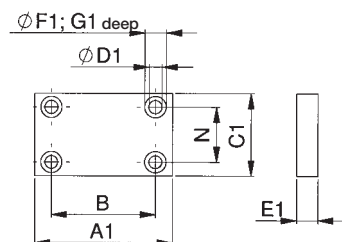

No. 6372 **Gripping jaw, smooth**
Hardened 60 HRc.



Order no.	Article no.	g
301176	6372-4048-E070	232
301192	6372-4041-E090	352
301218	6372-4042-E100	423
301234	6372-4043-E115	493
301259	6372-4044-E130	771
301275	6372-4045-E160	950
301291	6372-4046-E200	1790

Dimensions:

Size A	B	C	D	E	F	G
70	40	32	7.0	10	11	6.5
90	44	36	8.5	15	14	9.0
100	46	40	11.0	15	17	11.0
115	60	40	11.0	15	17	11.0
130	65	45	11.0	18	17	11.0
160	80	45	11.0	18	17	11.0
200	100	60	13.0	20	19	13.0

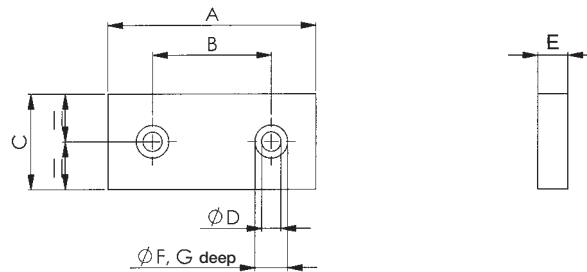

No. 6372 **Gripping jaw, knurled**
Hardened 60 HRc.



Order no.	Article no.	g
301317	6372-4071-E070	262
301333	6372-4073-E090	322
301358	6372-4074-E100	392
301374	6372-4075-E115	455
301390	6372-4076-E130	720
301416	6372-4077-E160	896
301432	6372-4078-E200	1661

Dimensions:

Size A	B	C	D	E	F	G
70	40	32	7.0	10	11	6.5
90	44	36	8.5	15	14	9.0
100	46	40	11.0	15	17	11.0
115	60	40	11.0	15	17	11.0
130	65	45	11.0	18	17	11.0
160	80	45	11.0	18	17	11.0
200	100	60	13.0	20	19	13.0

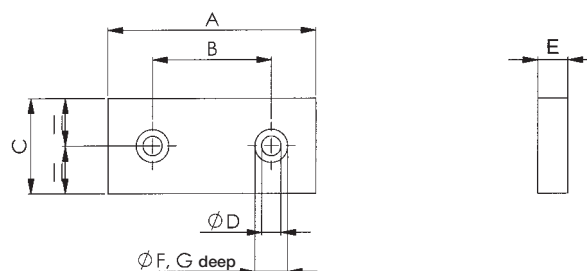

No. 6372

Gripping jaw, smooth

Not hardened, for individual processing.



Order no.	Article no.	g
301580	6372-4050-E070	235
301606	6372-4001-E090	359
301622	6372-4002-E100	426
301648	6372-4003-E115	495
301663	6372-4004-E130	775
301689	6372-4005-E160	955
301705	6372-4006-E200	1790

Dimensions:

Size A	B	C ±0.01	D	E ±0.01	F	G
70	40	32	7.0	10	11	6.5
90	44	36	8.5	15	14	9.0
100	46	40	11.0	15	17	11.0
115	60	40	11.0	15	17	11.0
130	65	45	11.0	18	17	11.0
160	80	45	11.0	18	17	11.0
200	100	60	13.0	20	19	13.0

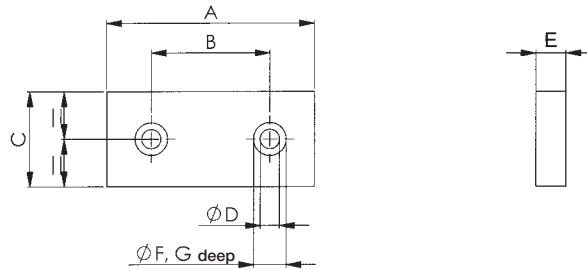

No. 6372

Gripping jaw, stepped

Hardened 60 HRC.



Order no.	Article no.	g
301440	6372-4061-E070	262
301465	6372-4007-E090	322
301481	6372-4008-E100	392
301507	6372-4009-E115	455
301523	6372-4010-E130	720
301549	6372-4011-E160	896
301564	6372-4012-E200	1661

Dimensions:

Size A	B	C ±0.01	D	E ±0.01	F	G	H ±0.01	I	K ±0.01
70	40	32	7.0	10	11	6.5	3	2.5	8
90	44	36	8.5	15	14	9.0	4	3.0	9
100	46	40	11.0	15	17	11.0	4	3.0	9
115	60	40	11.0	15	17	11.0	4	3.0	9
130	65	45	11.0	18	17	11.0	4	3.0	13
160	80	45	11.0	18	17	11.0	4	3.0	13
200	100	60	13.0	20	19	13.0	6	4.0	16

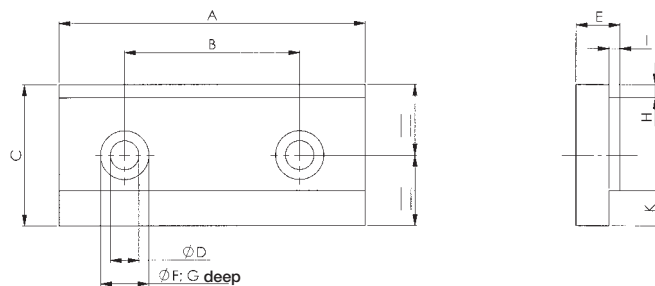

No. 6372

Modular jaw

Hardened 60 HRC.



Order no.	Article no.	g
301382	6372-4057-E070	239
301408	6372-4031-E090	305
301424	6372-4032-E100	370
301093	6372-4033-E115	435
301119	6372-4034-E130	697
301135	6372-4035-E160	865
301150	6372-4036-E200	1620

Dimensions:

Size A	B	C ±0.01	D	E ±0.01	F	G	I ±0.01	K ±0.01
70	40	32	7.0	10	11	6.5	2.5	20
90	44	36	8.5	15	14	9.0	3.0	22
100	46	40	11.0	15	17	11.0	3.0	23
115	60	40	11.0	15	17	11.0	3.0	23
130	65	45	11.0	18	17	11.0	3.0	28
160	80	45	11.0	18	17	11.0	3.0	28
200	100	60	13.0	20	19	13.0	4.0	37

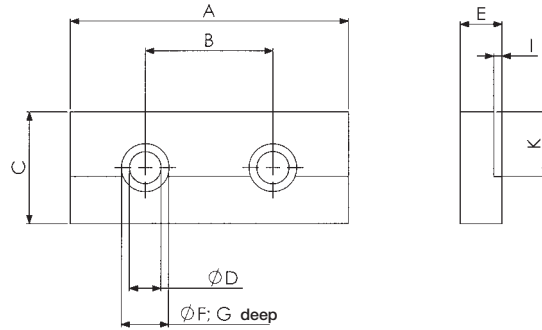

No. 6372

Gripping jaw, V-block

Hardened 60 HRC.



Order no.	Article no.	g
301515	6372-4054-E070	262
301531	6372-4013-E090	532
301556	6372-4014-E100	708
301572	6372-4015-E115	822
301598	6372-4016-E130	1079
301614	6372-4017-E160	1296
301630	6372-4018-E200	2260

Dimensions:

Size A	B	C ±0.01	D	E ±0.01	F	G	H
70	40	32	7	18	11	14	13.3
90	44	36	9	26	14	20	20.3
100	46	40	11	28	17	22	20.3
115	60	40	11	28	17	22	20.3
130	65	45	11	28	17	22	20.3
160	80	45	11	28	17	22	24.3
200	100	60	13	28	19	22	23.8

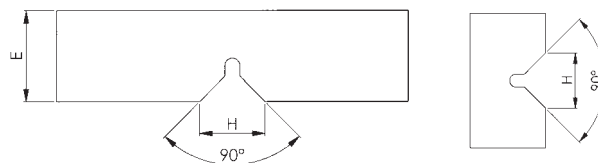
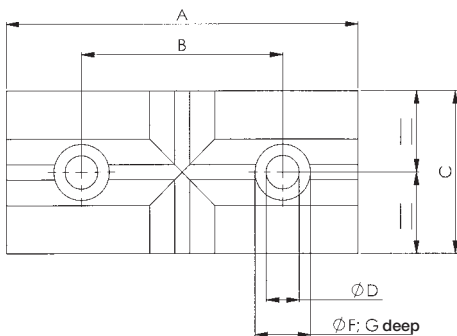

No. 6372

Stepped jaw

Hardened 60 HRC.



Order no.	Article no.	g
301721	6372-4055-E070	239
301747	6372-4019-E090	305
301762	6372-4020-E100	370
301788	6372-4021-E115	435
301457	6372-4022-E130	697
301473	6372-4023-E160	865
301499	6372-4024-E200	1620

Dimensions:

Size A	B	C ±0.01	D	E	F	G	H ±0.01	K ±0.01	L ±0.01	M ±0.01	N ±0.01
70	56	47	6.5	24	11	7	18	10	15	19	39
90	68	65	8.5	36	14	9	25	13	21	22	54
100	80	85	11.0	43	17	12	30	16	26	32	68
115	91	85	11.0	46	17	12	28	16	24	32	71
130	100	90	11.0	46	17	12	35	17	31	40	72
160	126	100	13.0	56	19	13	38	18	30	36	82
200	150	118	13.0	70	19	13	50	30	42	56	100

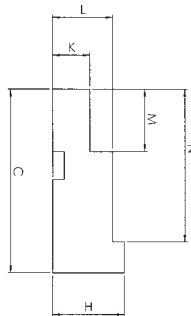
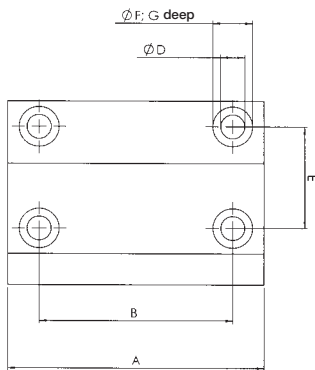

Application example:

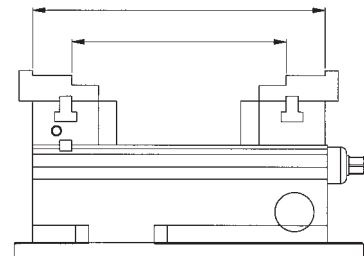

No. 6372

Angle jaw

Hardened 60 HRC.



Order no.	Article no.	g
301655	6372-4056-E070	382
301671	6372-4025-E090	877
301697	6372-4026-E100	1320
301713	6372-4027-E115	1481
301739	6372-4028-E130	2200
301754	6372-4029-E160	3300
301770	6372-4030-E200	5800

Dimensions:

Size A	B	C ±0.01	D	E	F	G	I ±0.01	K ±0.01	N
70	56	40	6.5	32	11	7	24	12	24
90	68	54	6.5	36	14	9	30	16	36
100	80	72	11.0	40	17	12	42	18	43
115	91	74	11.0	40	17	12	48	17	46
130	100	76	11.0	45	17	12	44	20	46
160	126	84	13.0	45	19	13	52	20	56
200	150	100	13.0	60	19	13	68	25	70

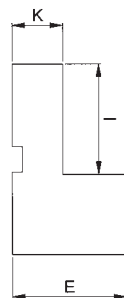
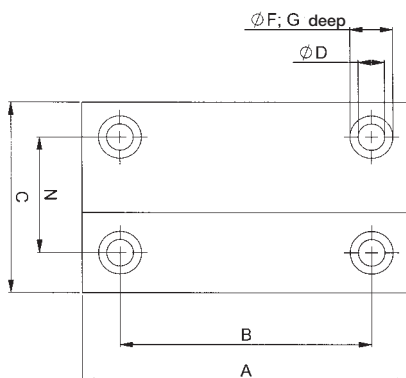

Application example:

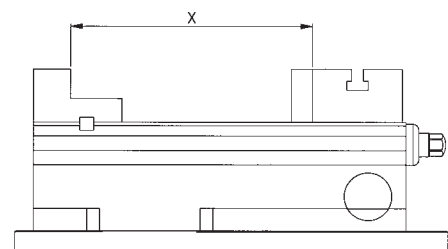

No. 6372 Double-ended clamp



Order no.	Article no.	A	B	C	D	E	F	L	g
301804	6372-5003-E070-E090	28	26	13	11	16	30	56	135
301796	6372-5001-E100-E200	38	30	17	16	18	34	60	226

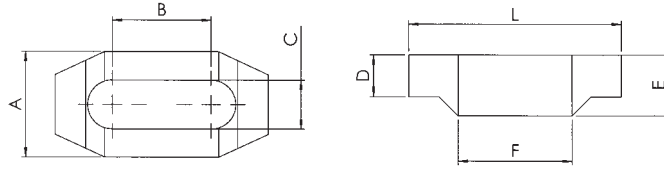

No. 6372 Straight clamp



Order no.	Article no.	A	B	C	D	E	F	G	L	M	g
301846	6372-5006-E070-E090	26	16	12	33	25	13	11	89	12	278
301820	6372-5002-E100-E200	50	19	15	47	50	21	16	125	12	524

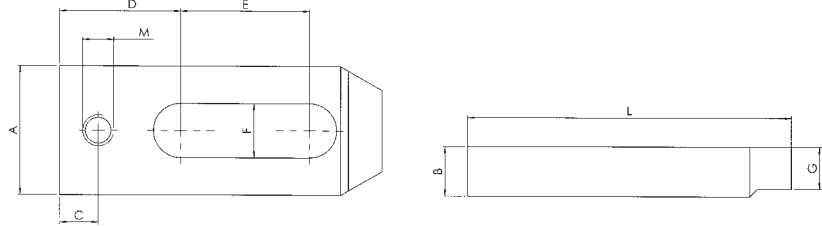

No. 6372 Stop



Order no.	Article no.	g
301861	6372-5004	643

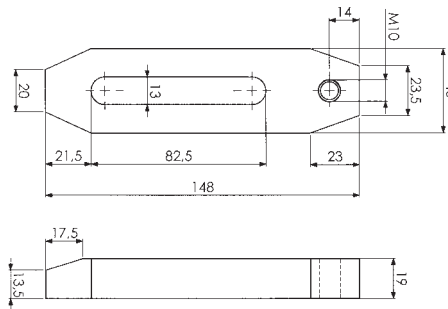

No. 6372 Pneumatic valve



Order no.	Article no.	g
301903	6372-6001	1037



No. 6372 Air-preparation unit



Order no.	Article no.	g
301929	6372-6002	1079

...by Article no.

Article no.	Page	Article no.	Page	Article no.	Page	Article no.	Page
6371-100-50-12	12	6371-4300-80	9	6372-1301-E130	15	6372-4029-E160	19
6371-100-80-12	12	6371-4351-80-012	13	6372-1600-E160	15	6372-4030-E200	19
6371-100-120-12	12	6371-4352-80-013	13	6372-2000-E200	15	6372-4031-E090	18
6371-1216-120-016	13	6371-4353-80-014	13	6372-3001-E090	15	6372-4032-E100	18
6371-1220-120-020	13	6371-4354-80-015	13	6372-3002-E100	15	6372-4033-E115	18
6371-1224-120-024	13	6371-4355-80-016	13	6372-3003-E115	15	6372-4034-E130	18
6371-1228-120-028	13	6371-4356-80-017	13	6372-3005-E160	15	6372-4035-E160	18
6371-4101-50	8	6371-4357-80-018	13	6372-3006-E200	15	6372-4036-E200	18
6371-4102-50	10	6371-4358-80-019	13	6372-3013-E070	15	6372-4041-E090	16
6371-4103-50-09	12	6371-4359-80-020	13	6372-4001-E090	17	6372-4042-E100	16
6371-4104-50-12	12	6371-4360-80-021	13	6372-4002-E100	17	6372-4043-E115	16
6371-4105-50-04	12	6371-4380-80	13	6372-4003-E115	17	6372-4044-E130	16
6371-4106-50-09	12	6371-4380-1-80	13	6372-4004-E130	17	6372-4045-E160	16
6371-4107-50-04	12	6371-4390-80	13	6372-4005-E160	17	6372-4046-E200	16
6371-4108-50-09	12	6371-4391-80	13	6372-4006-E200	17	6372-4048-E070	16
6371-4109-50	10	6371-9010-10	13	6372-4007-E090	17	6372-4050-E070	17
6371-4110-80	10	6371-9012-12	13	6372-4008-E100	17	6372-4054-E070	18
6371-4111-80	8	6371-9014-14	13	6372-4009-E115	17	6372-4055-E070	19
6371-4112-50	9	6371-9018-18	13	6372-4010-E130	17	6372-4056-E070	19
6371-4113-80-11	12	6371-12001-120	8	6372-4011-E160	17	6372-4057-E070	18
6371-4114-80-18	12	6371-12002-120	8	6372-4012-E200	17	6372-4061-E070	17
6371-4115-80-04	12	6371-12018-120-15	12	6372-4013-E090	18	6372-4071-E070	16
6371-4116-80-11	12	6371-12024-120-04	12	6372-4014-E100	18	6372-4073-E090	16
6371-4117-80-04	12	6371-12025-120-04	12	6372-4015-E115	18	6372-4074-E100	16
6371-4118-80-11	12	6371-50101-50	11	6372-4016-E130	18	6372-4075-E115	16
6371-4119-80	10	6371-50105-50	9	6372-4017-E160	18	6372-4076-E130	16
6371-4120-50	8	6371-50110-50	11	6372-4018-E200	18	6372-4077-E160	16
6371-4121-80	8	6371-80101-80	11	6372-4019-E090	19	6372-4078-E200	16
6371-4201-50-011	13	6371-80107-80	9	6372-4020-E100	19	6372-5001-E100-E200	20
6371-4202-50-012	13	6371-80110-80	11	6372-4021-E115	19	6372-5002-E100-E200	20
6371-4203-50-013	13	6371G-50	6	6372-4022-E130	19	6372-5003-E070-E090	20
6371-4204-50-014	13	6371G-80	6	6372-4023-E160	19	6372-5004	20
6371-4205-50-015	13	6371G-120	6	6372-4024-E200	19	6372-5006-E070-E090	20
6371-4206-50-016	13	6372-0700-E070	15	6372-4025-E090	19	6372-6001	20
6371-4220-50	13	6372-0900-E090	15	6372-4026-E100	19	6372-6002	20
6371-4221-50	13	6372-1002-E100	15	6372-4027-E115	19		
6371-4222-50	13	6372-1150-E115	15	6372-4028-E130	19		

...by Order no.

Order no.	Page	Order no.	Page	Order no.	Page	Order no.	Page
265793	8	301002	12	301432	16	301903	20
265835	10	301010	13	301440	17	301929	20
266569	12	301028	12	301457	19	304733	6
266577	13	301036	13	301465	17	304758	6
266585	12	301044	12	301473	19	304766	6
266593	13	301051	13	301481	17	304774	6
266601	12	301069	13	301499	19	304782	6
266619	13	301077	13	301507	17	304790	6
266627	13	301085	15	301515	18	304808	6
266635	13	301093	18	301523	17	304816	6
266643	13	301101	15	301531	18	304824	6
266650	13	301119	18	301549	17	304832	12
266668	13	301127	15	301556	18	304840	6
266676	13	301135	18	301564	17	304857	12
266684	13	301143	15	301572	18	304881	6
266700	13	301150	18	301580	17	304873	6
266726	13	301168	15	301598	18	304899	6
266742	13	301176	16	301606	17	304907	6
266809	8	301184	15	301614	18	304915	6
266825	10	301192	16	301622	17	304923	6
266841	12	301200	15	301630	18	304931	9
266866	12	301218	16	301648	17	304949	6
266882	12	301234	16	301655	19	304956	9
266908	13	301242	15	301663	17	304964	6
290635	8	301259	16	301671	19	304972	11
290650	8	301267	15	301689	17	304980	8
295006	13	301275	16	301697	19	304998	11
300863	10	301283	15	301705	17	305003	10
300871	13	301291	16	301713	19	305011	11
300889	10	301309	15	301721	19	305029	12
300897	13	301317	16	301739	19	305037	11
300905	9	301333	16	301747	19	305045	13
300913	13	301341	15	301754	19	305052	13
300921	9	301358	16	301762	19	305060	13
300939	13	301366	15	301770	19	305078	13
300947	12	301374	16	301788	19	305086	12
300954	13	301382	18	301796	20	305094	12
300962	12	301390	16	301804	20	305102	12
300970	13	301408	18	301820	20		
300988	12	301416	16	301846	20		
300996	13	301424	18	301861	20		

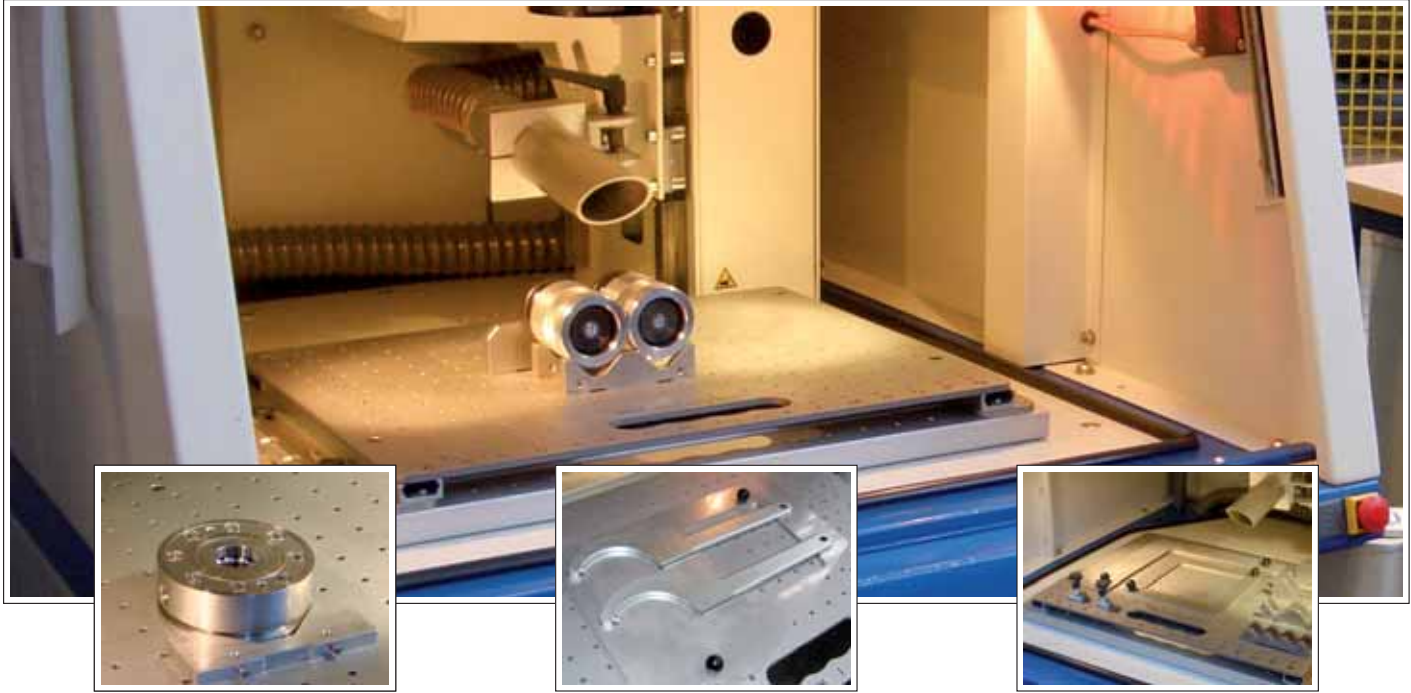

Are you also tired of complicated manual positioning on your laser marking machine?



No repeatability!



Tiring work!



Complicated re-positioning for each order!



High costs due to long set-up times!

With the new AMF positioning system, AMF offers you a solution to all of these problems!



- ▶ **Building-block principle**
- ▶ **Drawer system (fixed or sliding positioning base plate)**
- ▶ **Positioning accuracy 0.1 mm**
- ▶ **Repeatability 0.1 mm**
- ▶ **Modular structure**
- ▶ **Ergonomic**

These conditions of sale apply to business conducted with companies, legal entities in the public sector, and legal entities with special budget in the public sector. Our deliveries and services are carried out exclusively on the basis of the conditions stated below. Deviating purchasing conditions of the buyer will not become part of the contract, not even through acceptance of the order, unless we have expressly accepted them.

1. Offer and entering into a contract

The basis of our delivery contracts is the latest edition of our catalogue. Orders are not considered as accepted until they have been confirmed by us in writing. When goods are supplied from stock and, for organisational reasons, you receive no separate confirmation, the invoice has the additional function of confirming the order. Details of dimensions and weights, and illustrations, drawings and data are not binding and may be changed by us at any time. Deviations cannot be excluded.

2. Prices

Prices are quoted in EUR ex-works excluding turnover tax, packing, freight, carriage, and insurance. Unless otherwise agreed, our list prices on the day of delivery apply. In order to cover our costs, orders under EUR 50,- net value are subject to a small order surcharge of EUR 10,-.

3. Delivery

Delivery delays are quoted to the best of our knowledge but without guarantee. Agreed delivery delays begin on the day we accept the order and refer to the completion of the goods in our works.

4. Transfer of risk

Risks are transferred to you when the goods are passed to a specific person, company, or organisation that is charged with the execution of carriage of the goods. This applies also to partial deliveries and when we have accepted the costs of carriage, delivery or erection. The risks are also transferred to you when you have defaulted on acceptance.

5. Dispatch

Goods are supplied ex-works. Dispatch is at your cost and risk. Scheduled, FOB, and CIF deliveries are also at your risk. In the absence of specific instructions concerning dispatch, we will arrange same as we think fit, but without accepting any responsibility for choosing the cheapest or most suitable method of dispatch. We make a handling charge of EUR 5,- if goods are sent at your request to a third party. You accept that your order can be supplied in partial deliveries insofar as this is reasonable.

6. Reservation of proprietary rights

Goods delivered remain our property until payment of all claims has been received in full or until redemption of cheques given in payment. The cancellation of individual positions in an open invoice and the drawing of a balance and its acceptance do not affect proprietary rights. You have the right to dispose of the goods as a normal commercial transaction, but you are forbidden to pawn, mortgage, or transfer ownership of them in settlement of a debt or debts.

You surrender to us herewith your right to payment for goods for which we reserve our proprietary rights. You have the right to collect these payments as long as you meet your obligations to us. If we request it, you are obliged to name the third party and we have the right to publish this information and the transfer of rights.

7. Cancellation rights due to late payment or insolvency

If you do not pay for the goods by the time payment is due, and if you have not paid after expiry of a reasonable time limit set by us, we have the right to withdraw from the contract and demand the return of goods already supplied. Rights under § 323 BGB (BGB = German civil law code) remain otherwise unaffected.

Application for the opening of insolvency proceedings gives us the right to withdraw from the contract and demand the immediate return of goods supplied before the bankruptcy court orders protective measures.

8. Packaging

Packages comply with the German packaging regulations (WO). Disposable packaging is charged at cost. The packaging is not returnable.

9. Tooling costs

In the absence of any agreement to the contrary, tooling made for the execution of an order remains our property in all cases. This applies even if we have made a charge for a proportion of the tooling costs.

10. Payment

Our invoices are payable net within 30 days of the date of the invoice, or with 2%

discount if paid within 10 days. Invoices below EUR 50,- are payable immediately without discount.

Our credit notes and your charges on us reduce the amount subject to discount. Late payment entitles us to interest at the rate the bank charges us for a current account overdraft but at least 8 percent above the current base rate of the European Central Bank. If payment is overdue, we are entitled, after giving you notice in writing, to cease fulfilling our obligations under the contract until payment is received.

11. Offsetting exclusion

You can only offset payments with legally-established or unopposed counter claims.

12. Guarantee

If you come to an agreement with us on properties of the goods, we include this agreement in our technical specifications. If we have to supply to your drawings, specifications, samples, etc., you accept the risk associated with suitability for the intended purpose. The point in time at which risk is transferred is decisive for the contractual condition of the goods. The deterioration of parts subject to wear in the course of normal use does not constitute a defect.

If the goods supplied are defective, we will – at our choice and within a reasonable time limit set by you – supply a replacement or repair the goods. If such repair or replacement is not satisfactory, you have the right to reduce the price or withdraw from the contract. Any further guarantee claims are excluded. Recognisable defects must be notified at the latest within 10 days of receipt and defects that are not recognisable must be notified as soon as they are discovered. The guarantee period is 24 months and starts with dispatch of the goods from our works.

13. Hindered or impossible performance

If we are prevented from meeting our obligation by some unforeseeable event (e.g. disruption of our plant, or delay in the delivery of important raw materials), which, in spite of taking all reasonable care appropriate to the circumstances of the case, we have been unable to avert, and it has become impossible to execute the delivery or service punctually, the delivery delay will be extended to an appropriate extent.

14. Liability

Except in the case of injury to life or limb, or damage to health caused by our breach of duty, we are only liable in the event of intent or culpable negligence on our part.

15. Customer specials

Orders for customer specials must be in writing and include binding details of execution, quantities etc. For technical reasons we reserve the right to supply 10% more or less than the quantity specified.

If technical changes or cancellation are required, the costs incurred will be charged to the customer.

16. Deliveries of samples and return of goods

Samples will be charged. When goods have been sent for testing or as samples, we will credit you with the additional price against subsequent orders, as long as the net contract value is at least EUR 125,-.

The return of goods is only possible with prior agreement. Customer specials may not be returned. For goods returned for reasons outside our responsibility (e.g. wrongly ordered), we charge 10% of the value of the goods but at least EUR 7.50, to cover administration costs.

17. Place of fulfilment, court of jurisdiction

The place of fulfilment for all obligations arising from this contract is D-70707 Fellbach. The court of jurisdiction for any legal dispute arising from this contract is D-71332 Waiblingen.

(All disputes that arise from this contract or about its validity will be decided by a court of arbitration according to the Arbitration Rules of the German Committee for Arbitration Courts/Settlement and Arbitration Procedure of the International Chamber of Commerce. Such decisions will be final and normal legal procedures are excluded.) German law applies (BGB and HGB = civil and commercial codes). The application of UN purchasing law (CISG) is excluded.

18. Validity clause

If individual conditions should be found to be not legally valid, the remaining conditions continue to apply. The invalid conditions will be replaced by conditions which fulfil as closely as possible the commercial intent of the contract with reasonable consideration of the interests of both parties.

With the publication of these Conditions for Sales, Deliveries and Payment, all previous versions become invalid. This does not apply to contracts agreed before publication.