

Deep Reach Mill-Thread



Contents:

Toolholders
Extensions

Page:

174-176
176

Carmex presents a modular line of Mill-Thread toolholders

- Carmex modular holders are ideal for deep reach applications.
- Unique clamping method enables optimal strength and indexability.
- Cost saving - Same shank can hold different heads.
- Toolholders with internal coolant bore.
- Screw connection allows long overhang.
- Carmex standard thread milling inserts fit these toolholders.
- Different steel extensions are available.
- Toolholders are compatible with common toolholding systems.

Toolholders

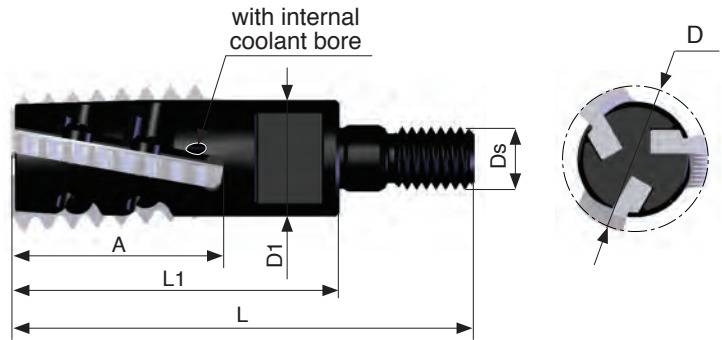

Ordering Code	Insert size A	D	D1	Ds	L1	L	No. of Inserts	Screw	Key
SRH19-3 S	27	19	15	M8	42.5	60	3	S19	K11

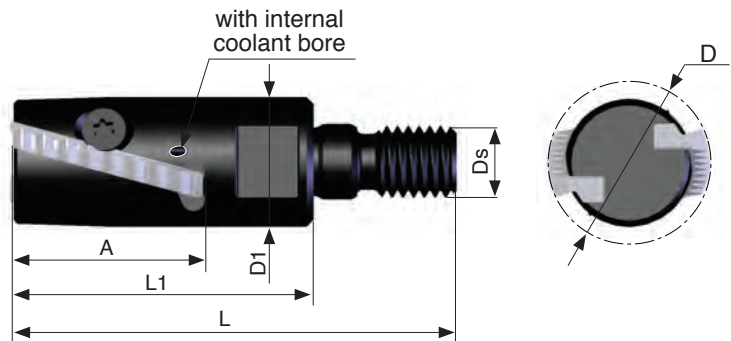

Ordering Code	Insert size A	D	D1	Ds	L1	L	No. of Inserts	Screw	Key
SRH23-2 S	27	23	18	M10	42.5	62.5	2	S23	K16

Deep Reach Mill-Thread

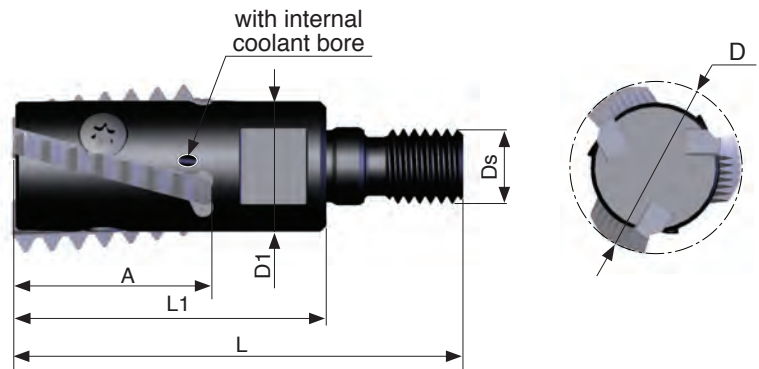

Ordering Code	Insert size A	D	D1	Ds	L1	L	No. of Inserts	Screw	Key
SRH28-3 S	32	28	21	M12	50	72	3	S28	K16

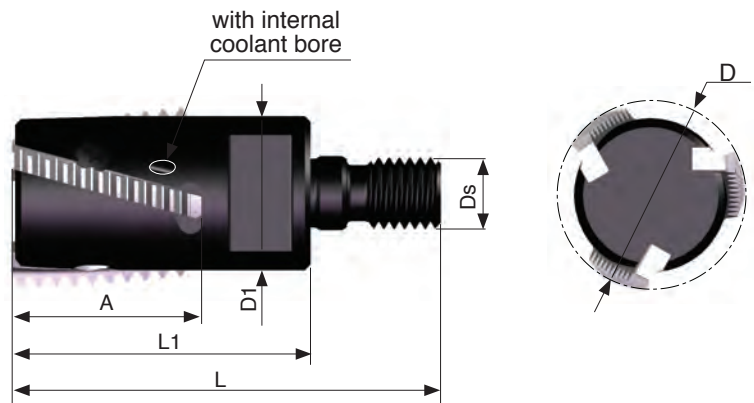

Ordering Code	Insert size A	D	D1	Ds	L1	L	No. of Inserts	Screw	Key
SRH32-3 S	32	32	26	M12	50	72	3	S32S	K16

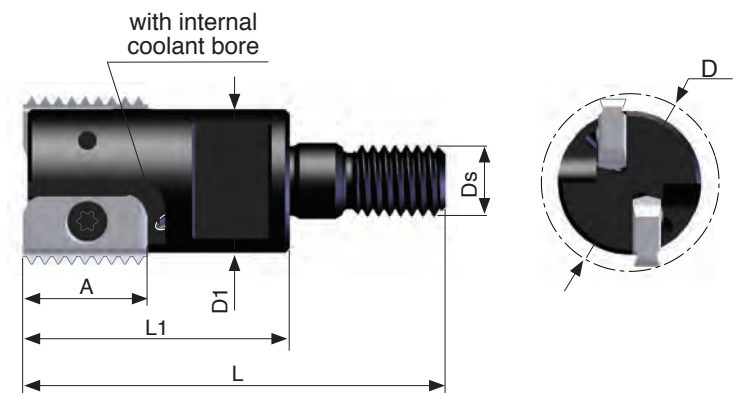

Ordering Code	Insert size A	D	D1	Ds	L1	L	No. of Inserts	Screw	Key
SR0020C14-2 S	14	20	16	M8	30.5	48	2	S14	K14

Toolholders

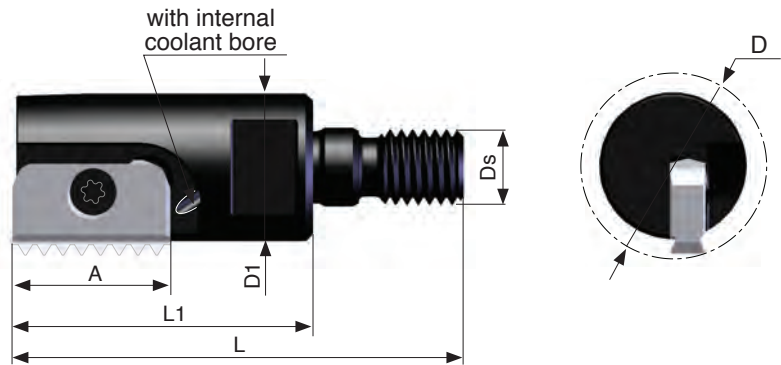

Ordering Code	Insert size A	D	D1	Ds	L1	L	No. of Inserts	Screw	Key
SR0025D21-1 S	21	25	19.7	M10	40	60	1	S21	K21

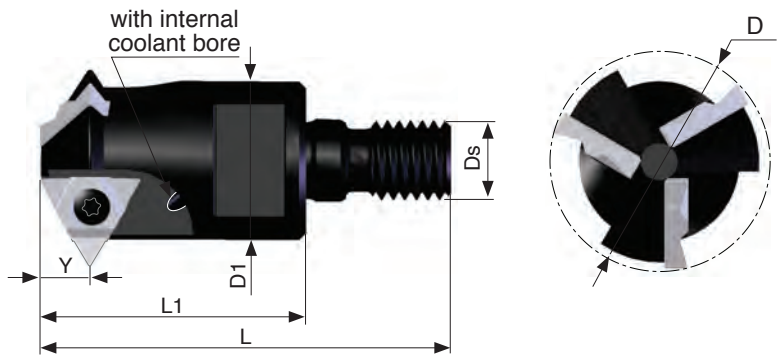

Ordering Code	Insert size		Y	D	D1	Ds	L1	L	No. of Inserts	Screw	Key
	L	I.C.									
SR0033D16U-3 S	16U	3/8U	7.6	33	24	M12	40	60	3	S16	K16

Extensions

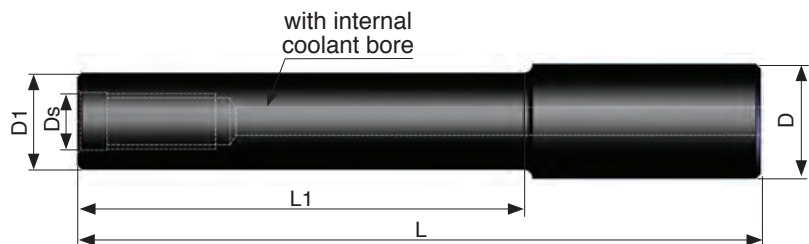

Ordering Code	D	D1	Ds	L	L1
E16 M08 L80	16	15	M08	80	30
E20 M10 L80	20	18	M10	80	30
E20 M10 L130	20	18	M10	130	80
E25 M12 L100	25	21	M12	100	50
E25 M12 L150	25	21	M12	150	100