

Mill-Thread Toolholders



Contents:

Page:

Product Identification	152
Single Insert Toolholders	153
Long Shank Toolholders	153
Twin Insert Toolholders	154
Multi Insert Toolholders	155
External Multi Insert Toolholders	155
Long Carbide Shank Toolholders	156
Carbide Shank Toolholders for Single Point Threading	156

Product Identification

Mill-Thread Toolholders Ordering Codes

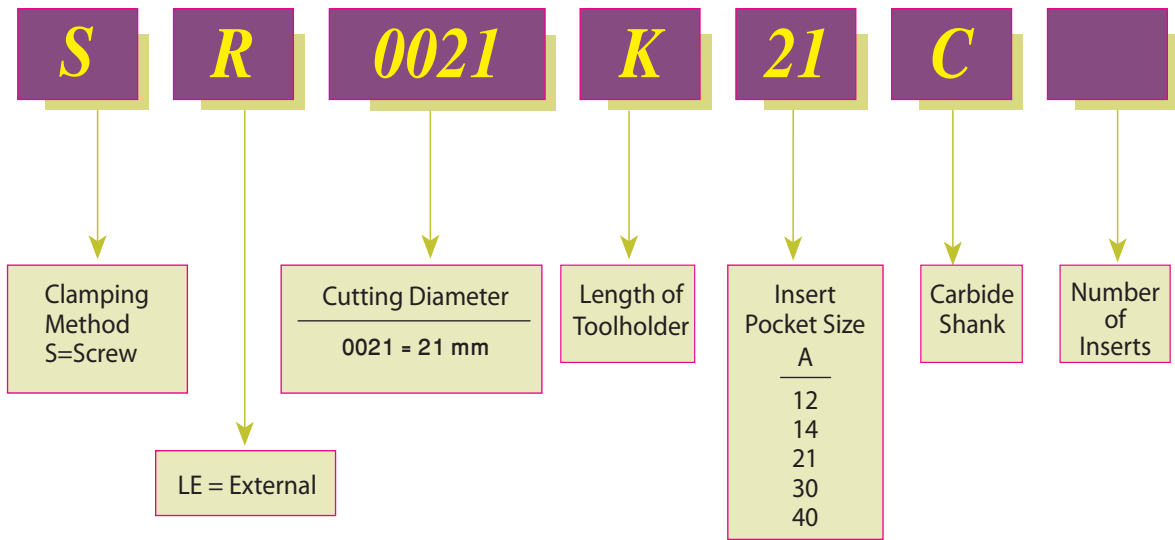

Single Insert Toolholders

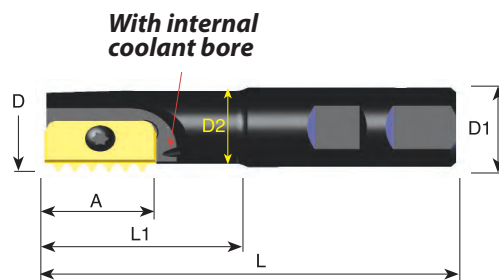

Ordering Code	A	D	D1	D2	L	L1	Insert Screw	Torx Key
* SR0009H12	12	9.5	20	7.5	85	14	S12	K12
SR0010H12	12	9.9	20	7.6	85	16	S12	K12
SR0012F14	14	12.0	20	8.9	75	20	S14	K14
SR0014H14	14	14.5	20	11.2	85	25	S14	K14
SR0017H14	14	17.0	20	13.4	85	30	S14	K14
** SR0018H21	21	18.0	20	14.4	85	30	S21	K21
SR0021H21	21	21.0	20	16.5	94	40	S21	K21
SR0029J30	30	29.0	25	22.4	110	50	S30	K30
SR0048M40	40	48.0	40	35.0	153	78	S40	K40

Order example: SR0029J30

* Not for conical inserts: 12-18 NPT, 12-18 NPTF, 12-19 BSPT

** Cannot be used with the following inserts:

21 I 3.5 ISO, 21 I 8 UN, 21 I 7 UN, 21-11 BSPT, 21-11.5 NPT, 21-11.5 NPTF

Long Shank Toolholders

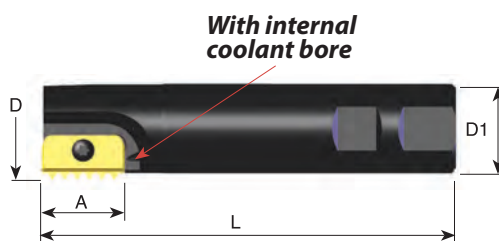

Ordering Code	A	D	D1	L	Insert Screw	Torx Key
SR0025K21	21	25	20	125	S21	K21
SR0031M30	30	31	25	150	S30	K30
SR0038M30	30	38	32	150	S30	K30
SR0048R40	40	48	40	210	S40	K40

Order example: SR0031M30

For holders with long overhang reduce the cutting speed and feed rate between 20% to 40% (depends on workpiece material, pitch and overhang)

Twin Insert Toolholders

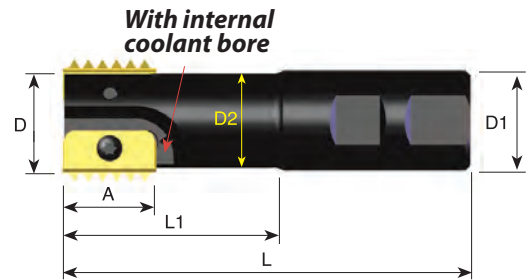

Ordering Code	A	D	D1	D2	L	L1	No. of Inserts	Insert Screw	Torx Key
SR0020H14-2	14	20	20	16	93	41	2	S14	K14
SR0030J21-2	21	30	25	24	108	52	2	S21	K21
SR0040L30-2	30	40	32	30	130	70	2	S30	K30
SR0050M40-2	40	50	40	38	153	78	2	S40	K40

Order example: SR0040L30-2

Multi Insert Toolholders

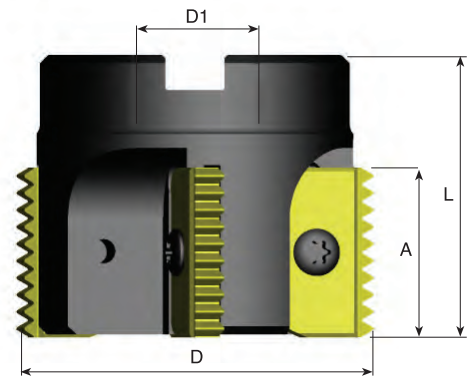
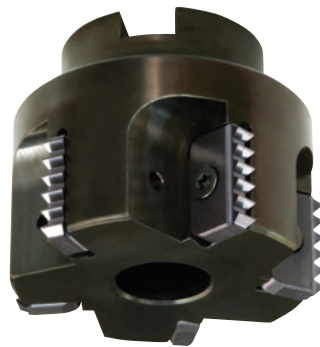

Ordering Code	A	D	D1	L	No. of Inserts	Insert Screw	Torx Key
SR0063C21-5	21	63	22	50	5	S21	K21
SR0063C30-4	30	63	22	50	4	S30	K30
SR0080D30-4	30	80	27	55	4	S30	K30
SR0100D30-4	30	100	32	60	4	S30	K30
SR0100D30-8	30	100	32	60	8	S30	K30
SR0080D40-4	40	80	27	65	4	S40	K40
SR0100E40-4	40	100	32	70	4	S40	K40
SR0100E40-6	40	100	32	70	6	S40	K40

Order example: SR0080D30-4

External Multi Insert Toolholder

- Reduced machining time
- Optimal coolant supply

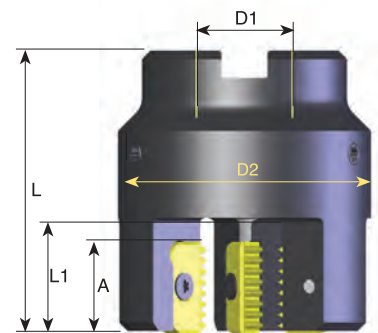
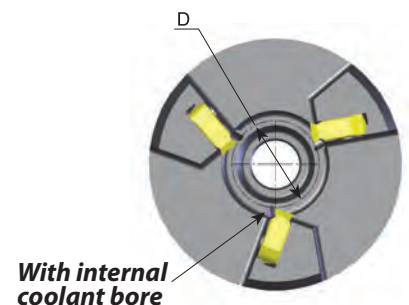
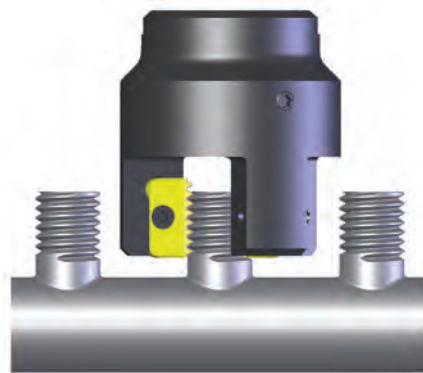

Ordering Code	A	D	D1	D2	L	L1	No. of Inserts	Insert Screw	Torx Key
SLE0020D21-3	21	20	22	58	65	25	3	S21	K21
SLE0030D21-3	21	30	22	68	65	25	3	S21	K21
SLE0045E21-4	21	45	27	83	70	25	4	S21	K21

Order example: SLE0030D21-3

Long Carbide Shank Toolholders

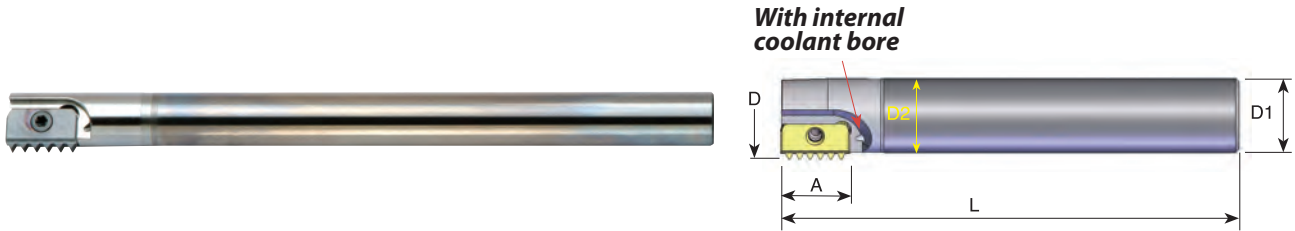



Ordering Code	A	D	D1	D2	L	Insert Screw	Torx Key
SR0010K12C	12	9.9	8	8	125	S12	K12
SR0013H14C	14	13.2	10	10	110	S14	K14
SR0013J14C	14	13.2	10	10	155	S14	K14
SR0015K14C	14	15.2	12	12	175	S14	K14
SR0021K21C	21	21.0	16	16	130	S21	K21
SR0021M21C	21	21.0	16	16	200	S21	K21
SR0027S30C	30	27.0	20	20	270	S30	K30

Order example: SR0015K14C

For holders with long overhang reduce the cutting speed and feed rate between 20% to 40% (depends on workpiece material, pitch and overhang)

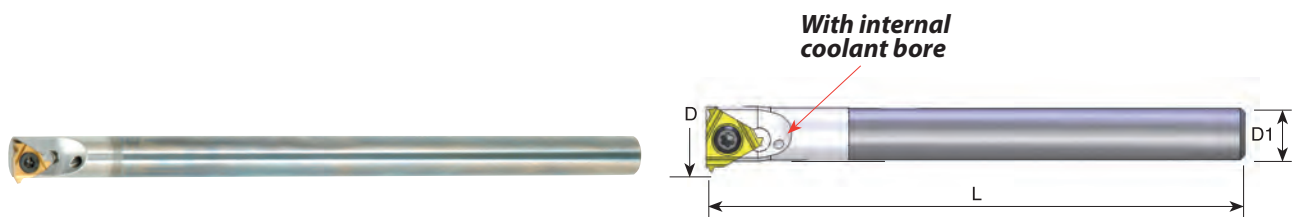
Carbide Shank Toolholders for Single Point Threading



Ordering Code		Pitch Range		D	D1	L	Insert Screw	Torx Key
		mm	TPI					
SR0005D06C	6	0.5-1.25	48-20	6.8	5.0	63	S06	K06
SR0006H08C	8	0.5-1.75	48-14	8.8	6.0	100	S08	K08
* SR0010M11C	11	0.5-2.00	48-11	13.2	10.0	150	S11	K11

For Inserts see the Thread Turning Tools section of this catalog

For an internal application use an internal R.H. insert.

* For an external application use an external L.H. insert.