

# Swiss-Line



Contents:	Page:	Contents:	Page:
Introduction	116	Threading - Partial Profile 55°	124
Product Identification - Inserts	117	Threading - ISO metric 60°	125
Grooving	118	Threading - UN unified 60°	126
Grooving and Profiling (full radius)	119	Product Identification - Toolholders	127
Parting Off	120-121	External Toolholders	127-128
Back Turning	122	Grooving, Parting Off, Turning, Profiling,	129
Front Turning	122	Threading, Working Method	
Threading - Partial Profile 60°	123	Cutting Data	130

## Swiss-Line

- Swiss style lathes are becoming a popular alternative to large lathes and machining centers in many companies.
- Carmex is introducing Swiss line of inserts and toolholders, developed for automatic and Swiss style lathes.
- Designed for economic production of parting, grooving, profiling and chamfering.

## Advantages

Advanced sub-micron grade (K10-K30) - a combination of strength, toughness, wear resistance and edge sharpness.

- Grounded cutting edges.
- Advanced and unique PVD triple coating, for high wear and heat resistance.
- For most types of material, including Stainless Steels, Titanium and Super Alloys.

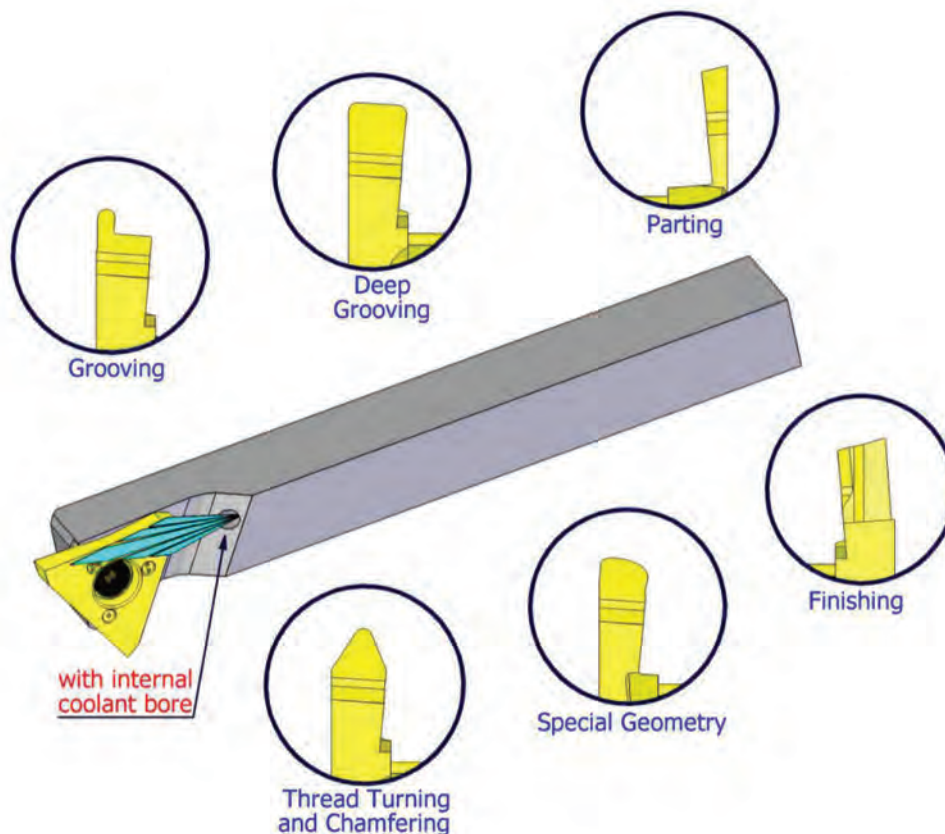

- Three cutting edges.
- The insert can be indexed directly on the machine.
- Internal coolant to the cutting edge.

## Product Identification - Inserts

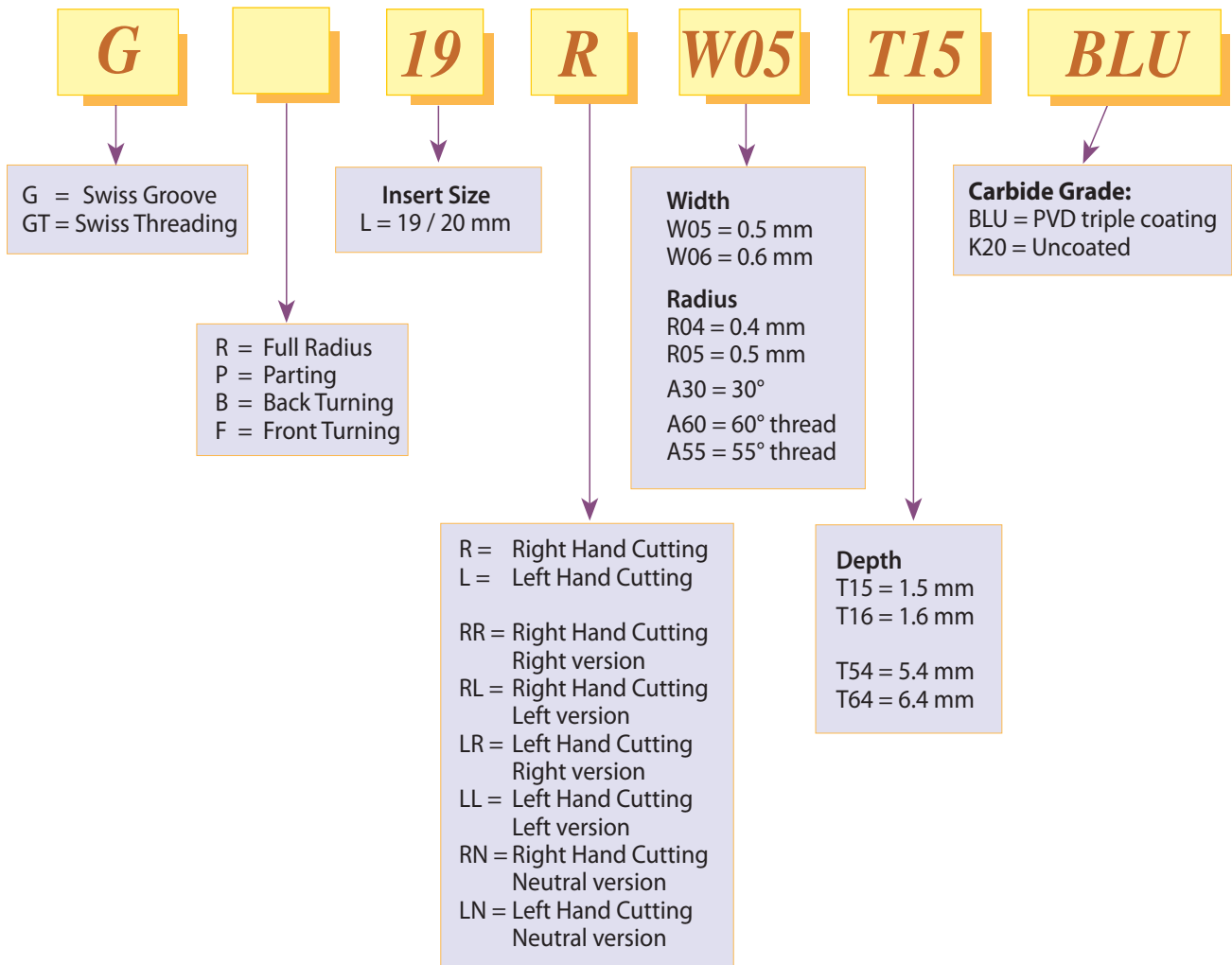

## Grooving

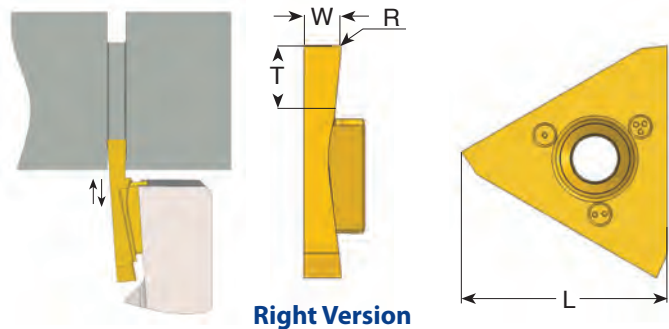

### Right hand cutting

L	Ordering Code	W $\pm 0.02$	T max	R	Feed mm/rev	
					Radial	Axial
19	G19 R W05 T15	0.5	1.5	0	0.01-0.06	0.02-0.10
	G19 R W06 T16	0.6	1.6	0	0.01-0.06	0.02-0.10
	G19 R W07 T17	0.75	1.7	0	0.01-0.06	0.02-0.10
	G19 R W08 T18	0.8	2.0	0.05	0.01-0.06	0.02-0.10
	G19 R W10 T22	1.0	2.5	0.05	0.02-0.07	0.02-0.10
	G19 R W12 T24	1.2	3.0	0.05	0.02-0.07	0.02-0.10
	G19 R W14 T28	1.4	3.0	0.05	0.03-0.08	0.02-0.10
	G19 R W15 T30	1.5	3.0	0.05	0.03-0.08	0.02-0.10
20	G19 R W17 T34	1.7	4.0	0.05	0.04-0.09	0.02-0.20
	G20 R W20 T40	2.0	4.0	0.1	0.05-0.10	0.02-0.20
	G20 R W22 T45	2.25	5.0	0.1	0.05-0.10	0.02-0.20
	G20 R W25 T50	2.5	6.0	0.1	0.05-0.10	0.02-0.20
	G20 R W30 T60	3.0	6.0	0.1	0.05-0.10	0.02-0.20

### Left hand cutting

L	Ordering Code	W $\pm 0.02$	T max	R	Feed mm/rev	
					Radial	Axial
19	G19 L W05 T15	0.5	1.5	0	0.01-0.06	0.02-0.10
	G19 L W06 T16	0.6	1.6	0	0.01-0.06	0.02-0.10
	G19 L W07 T17	0.75	1.7	0	0.01-0.06	0.02-0.10
	G19 L W08 T18	0.8	2.0	0.05	0.01-0.06	0.02-0.10
	G19 L W10 T22	1.0	2.5	0.05	0.02-0.07	0.02-0.10
	G19 L W12 T24	1.2	3.0	0.05	0.02-0.07	0.02-0.10
	G19 L W14 T28	1.4	3.0	0.05	0.03-0.08	0.02-0.10
	G19 L W15 T30	1.5	3.0	0.05	0.03-0.08	0.02-0.10
20	G19 L W17 T34	1.7	4.0	0.05	0.04-0.09	0.02-0.20
	G20 L W20 T40	2.0	4.0	0.1	0.05-0.10	0.02-0.20
	G20 L W22 T45	2.25	5.0	0.1	0.05-0.10	0.02-0.20
	G20 L W25 T50	2.5	6.0	0.1	0.05-0.10	0.02-0.20
	G20 L W30 T60	3.0	6.0	0.1	0.05-0.10	0.02-0.20

## Grooving and Profiling (full radius)

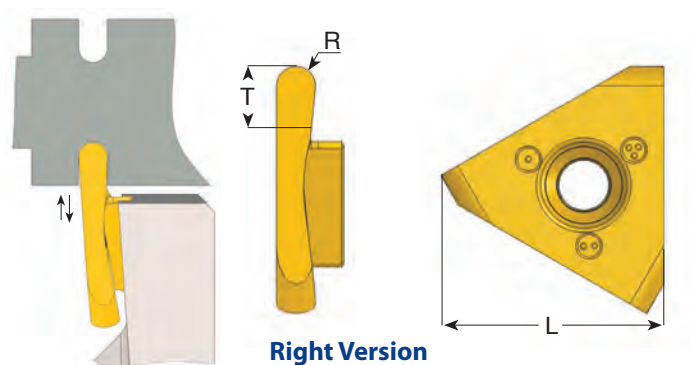

### Right hand cutting

L	Ordering Code	R ±0.03	T max	Feed mm/rev	
				Radial	Axial
19	<b>GR19 R R02 T15</b>	0.25	1.5	0.01-0.06	0.02-0.10
	<b>GR19 R R04 T18</b>	0.40	2.0	0.01-0.06	0.02-0.10
	<b>GR19 R R05 T22</b>	0.50	2.5	0.02-0.07	0.02-0.10
	<b>GR19 R R06 T26</b>	0.60	3.0	0.02-0.07	0.02-0.10
	<b>GR19 R R08 T33</b>	0.80	3.5	0.04-0.09	0.02-0.20
	<b>GR19 R R10 T40</b>	1.00	4.0	0.05-0.10	0.02-0.20
20	<b>GR20 R R12 T50</b>	1.25	6.0	0.05-0.10	0.02-0.20
	<b>GR20 R R15 T60</b>	1.50	6.0	0.05-0.10	0.02-0.20

### Left hand cutting

L	Ordering Code	R ±0.03	T max	Feed mm/rev	
				Radial	Axial
19	<b>GR19 L R02 T15</b>	0.25	1.5	0.01-0.06	0.02-0.10
	<b>GR19 L R04 T18</b>	0.40	2.0	0.01-0.06	0.02-0.10
	<b>GR19 L R05 T22</b>	0.50	2.5	0.02-0.07	0.02-0.10
	<b>GR19 L R06 T26</b>	0.60	3.0	0.02-0.07	0.02-0.10
	<b>GR19 L R08 T33</b>	0.80	3.5	0.04-0.09	0.02-0.20
	<b>GR19 L R10 T40</b>	1.00	4.0	0.05-0.10	0.02-0.20
20	<b>GR20 L R12 T50</b>	1.25	6.0	0.05-0.10	0.02-0.20
	<b>GR20 L R15 T60</b>	1.50	6.0	0.05-0.10	0.02-0.20

# Parting Off

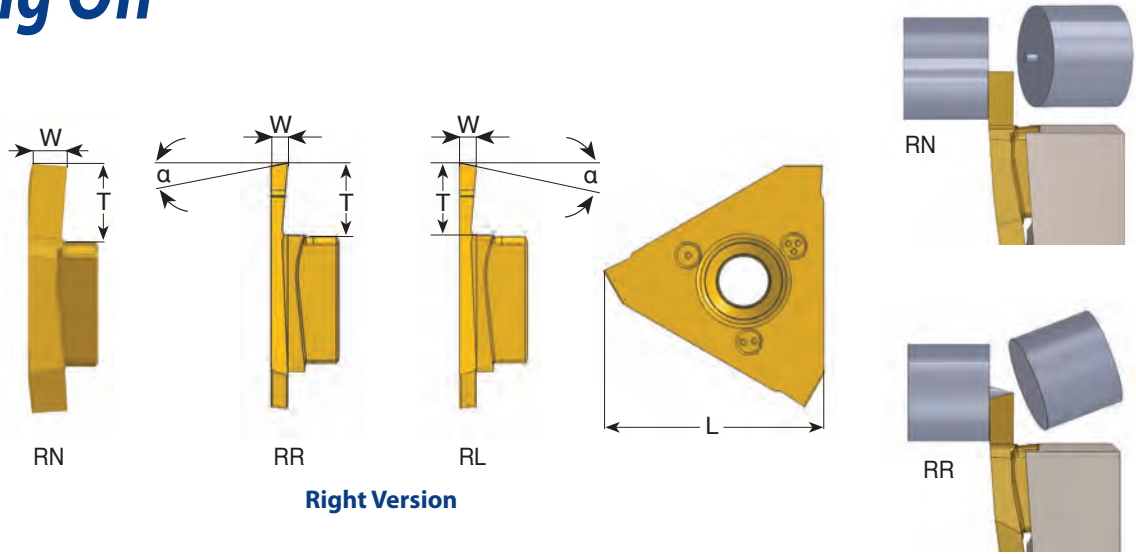

**Right Version**

## Right hand cutting

L	Ordering Code	W	$\alpha^\circ$	T max	Feed mm/rev Radial
19	GP19 RR W10 T54	1.0	15	5.4	0.02-0.09
	GP19 RL W10 T54	1.0	15	5.4	0.02-0.09
	GP19 RN W10 T54	1.0	0	5.4	0.02-0.09
	GP19 RR W12 T54	1.2	15	5.4	0.02-0.09
	GP19 RL W12 T54	1.2	15	5.4	0.02-0.09
	GP19 RN W12 T54	1.2	0	5.4	0.02-0.09
20	GP20 RR W15 T64	1.5	15	6.4	0.04-0.10
	GP20 RL W15 T64	1.5	15	6.4	0.04-0.10
	GP20 RN W15 T64	1.5	0	6.4	0.04-0.10
	GP20 RR W18 T64	1.8	15	6.4	0.04-0.10
	GP20 RL W18 T64	1.8	15	6.4	0.04-0.10
	GP20 RN W18 T64	1.8	0	6.4	0.04-0.10
	GP20 RR W20 T64	2.0	15	6.4	0.05-0.12
	GP20 RL W20 T64	2.0	15	6.4	0.05-0.12
	GP20 RN W20 T64	2.0	0	6.4	0.05-0.12
	GP20 RR W25 T64	2.5	15	6.4	0.05-0.12
	GP20 RL W25 T64	2.5	15	6.4	0.05-0.12
	GP20 RN W25 T64	2.5	0	6.4	0.05-0.12
	GP20 RR W30 T64	3.0	15	6.4	0.05-0.12
	GP20 RL W30 T64	3.0	15	6.4	0.05-0.12
GP20 RN W30 T64	3.0	0	6.4	0.05-0.12	

\* Corner Radius RO

## Parting Off

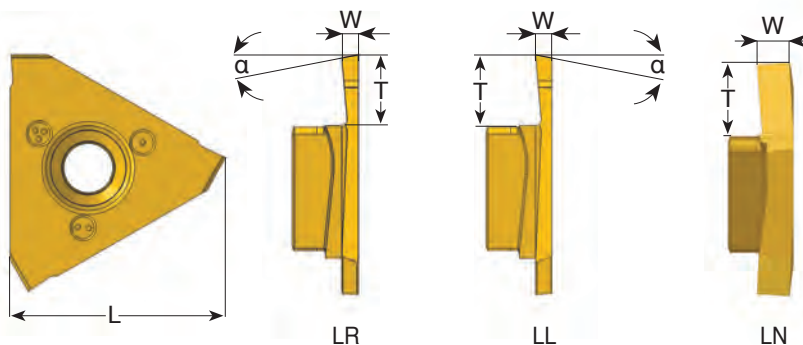

**Left Version**

### Left hand cutting

L	Ordering Code	W	$\alpha^\circ$	T max	Feed mm/rev Radial
19	GP19 LR W10 T54	1.0	15	5.4	0.02-0.09
	GP19 LL W10 T54	1.0	15	5.4	0.02-0.09
	GP19 LN W10 T54	1.0	0	5.4	0.02-0.09
	GP19 LR W12 T54	1.2	15	5.4	0.02-0.09
	GP19 LL W12 T54	1.2	15	5.4	0.02-0.09
	GP19 LN W12 T54	1.2	0	5.4	0.02-0.09
20	GP20 LR W15 T64	1.5	15	6.4	0.04-0.10
	GP20 LL W15 T64	1.5	15	6.4	0.04-0.10
	GP20 LN W15 T64	1.5	0	6.4	0.04-0.10
	GP20 LR W18 T64	1.8	15	6.4	0.04-0.10
	GP20 LL W18 T64	1.8	15	6.4	0.04-0.10
	GP20 LN W18 T64	1.8	0	6.4	0.04-0.10
	GP20 LR W20 T64	2.0	15	6.4	0.05-0.12
	GP20 LL W20 T64	2.0	15	6.4	0.05-0.12
	GP20 LN W20 T64	2.0	0	6.4	0.05-0.12
	GP20 LR W25 T64	2.5	15	6.4	0.05-0.12
	GP20 LL W25 T64	2.5	15	6.4	0.05-0.12
	GP20 LN W25 T64	2.5	0	6.4	0.05-0.12
	GP20 LR W30 T64	3.0	15	6.4	0.05-0.12
	GP20 LL W30 T64	3.0	15	6.4	0.05-0.12
GP20 LN W30 T64	3.0	0	6.4	0.05-0.12	

\* Corner Radius R0

# Back Turning

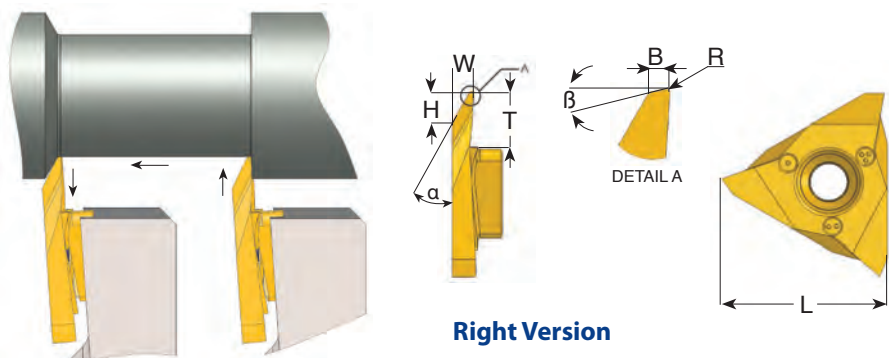

## Right hand cutting

L	Ordering Code	$\alpha^\circ$	$\beta^\circ$	R	W	H	B	T	Feed mm/rev
19	<b>GB19 R A30</b>	30	12	0.1	3.4	4.3	0.5	5.4	0.05-0.15
20	<b>GB20 R A30</b>	30	12	0.1	3.4	4.3	0.5	6.4	0.05-0.15

## Left hand cutting

L	Ordering Code	$\alpha^\circ$	$\beta^\circ$	R	W	H	B	T	Feed mm/rev
19	<b>GB19 L A30</b>	30	12	0.1	3.4	4.3	0.5	5.4	0.05-0.15
20	<b>GB20 L A30</b>	30	12	0.1	3.4	4.3	0.5	6.4	0.05-0.15

# Front Turning

## Right hand cutting

L	Ordering Code	T	Feed mm/rev
19	<b>GF19 R T54</b>	5.4	0.05-0.15
20	<b>GF20 R T64</b>	6.4	0.05-0.15

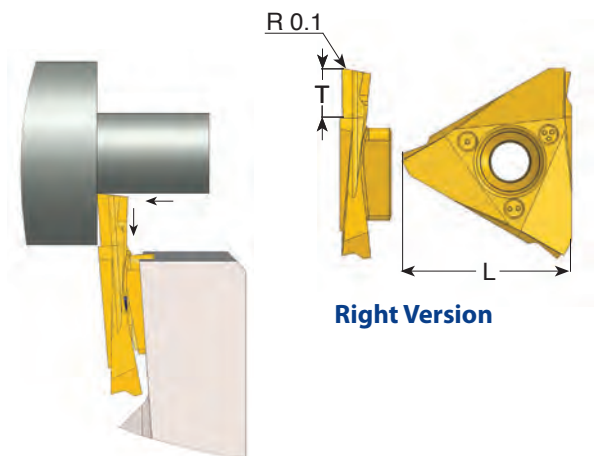

## Left hand cutting

L	Ordering Code	T	Feed mm/rev
19	<b>GF19 L T54</b>	5.4	0.05-0.15
20	<b>GF20 L T64</b>	6.4	0.05-0.15



## Threading - Partial Profile 60° External Thread

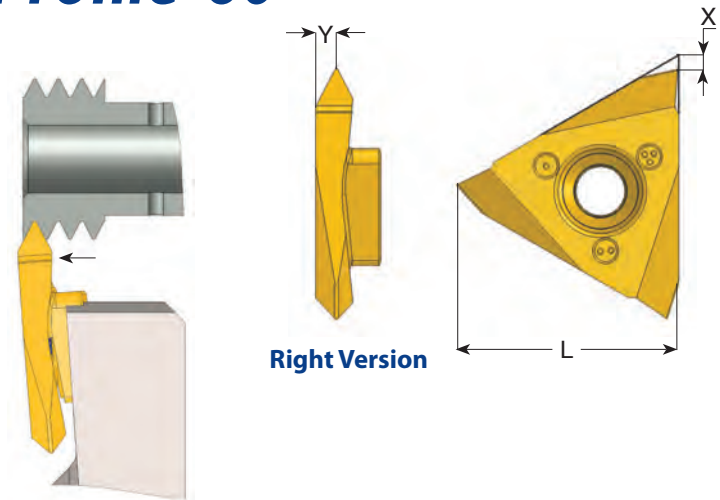

### Right hand cutting

L	mm	TPI	Ordering Code	X	Y
19	0.5-1.5	48-16	<b>GT19 R A60</b>	2.8	1.1
	1.75-3.0	14-8	<b>GT19 R G60</b>	2.8	1.7
	0.5-3.0	48-8	<b>GT19 R AG60</b>	2.8	1.7

### Left hand cutting

L	mm	TPI	Ordering Code	X	Y
19	0.5-1.5	48-16	<b>GT19 L A60</b>	2.8	1.1
	1.75-3.0	14-8	<b>GT19 L G60</b>	2.8	1.7
	0.5-3.0	48-8	<b>GT19 L AG60</b>	2.8	1.7

# Threading - Partial Profile 55° External Thread

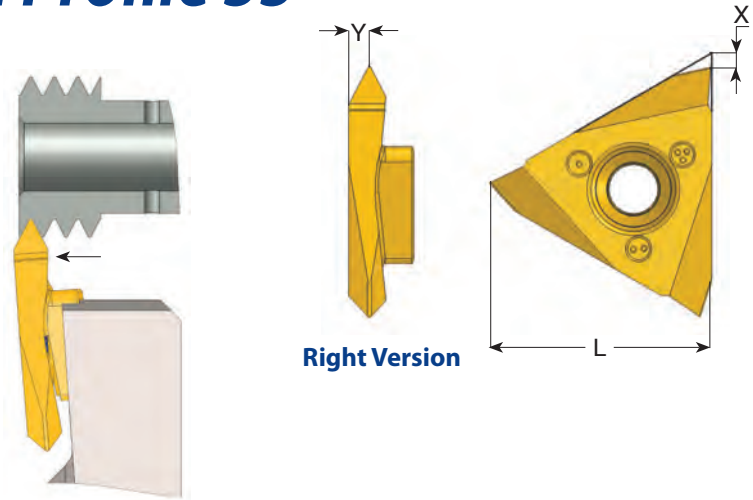

## Right hand cutting

L	mm	TPI	Ordering Code	X	Y
19	0.5-1.5	48-16	<b>GT19 R A55</b>	2.8	1.0
	1.75-3.0	14-8	<b>GT19 R G55</b>	2.8	1.7
	0.5-3.0	48-8	<b>GT19 R AG55</b>	2.8	1.7

## Left hand cutting

L	mm	TPI	Ordering Code	X	Y
19	0.5-1.5	48-16	<b>GT19 L A55</b>	2.8	1.0
	1.75-3.0	14-8	<b>GT19 L G55</b>	2.8	1.7
	0.5-3.0	48-8	<b>GT19 L AG55</b>	2.8	1.7

## Threading - ISO metric 60° External Thread

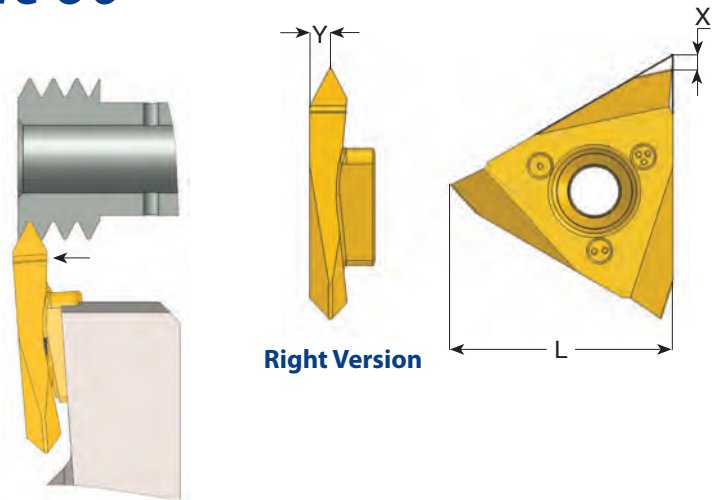

Right Version

### Right hand cutting

L	mm	Ordering Code	X	Y
19	0.5	<b>GT19 R 0.5 ISO</b>	2.8	0.6
	0.7	<b>GT19 R 0.7 ISO</b>	2.8	0.7
	0.75	<b>GT19 R 0.75 ISO</b>	2.8	0.7
	0.8	<b>GT19 R 0.8 ISO</b>	2.8	0.7
	1.0	<b>GT19 R 1.0 ISO</b>	2.8	0.8
	1.25	<b>GT19 R 1.25 ISO</b>	2.8	1.0
	1.5	<b>GT19 R 1.5 ISO</b>	2.8	1.1
	1.75	<b>GT19 R 1.75 ISO</b>	2.8	1.3

### Left hand cutting

L	mm	Ordering Code	X	Y
19	0.5	<b>GT19 L 0.5 ISO</b>	2.8	0.6
	0.7	<b>GT19 L 0.7 ISO</b>	2.8	0.7
	0.75	<b>GT19 L 0.75 ISO</b>	2.8	0.7
	0.8	<b>GT19 L 0.8 ISO</b>	2.8	0.7
	1.0	<b>GT19 L 1.0 ISO</b>	2.8	0.8
	1.25	<b>GT19 L 1.25 ISO</b>	2.8	1.0
	1.5	<b>GT19 L 1.5 ISO</b>	2.8	1.1
	1.75	<b>GT19 L 1.75 ISO</b>	2.8	1.3

# Threading - UN unified 60° External Thread

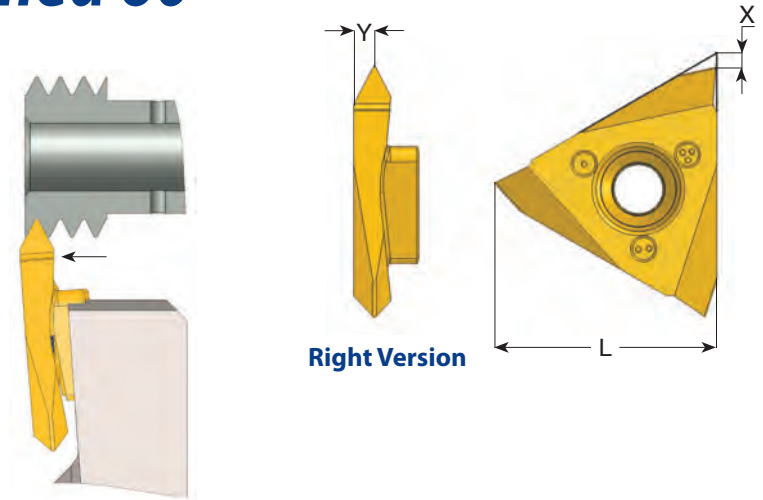

Right Version

## Right hand cutting

L	TPI	Ordering Code	X	Y
19	72	<b>GT19 R 72UN</b>	2.8	0.4
	56	<b>GT19 R 56UN</b>	2.8	0.6
	40	<b>GT19 R 40UN</b>	2.8	0.7
	32	<b>GT19 R 32UN</b>	2.8	0.7
	24	<b>GT19 R 24UN</b>	2.8	0.8
	20	<b>GT19 R 20UN</b>	2.8	1.0

## Left hand cutting

L	TPI	Ordering Code	X	Y
19	72	<b>GT19 L 72UN</b>	2.8	0.4
	56	<b>GT19 L 56UN</b>	2.8	0.6
	40	<b>GT19 L 40UN</b>	2.8	0.7
	32	<b>GT19 L 32UN</b>	2.8	0.7
	24	<b>GT19 L 24UN</b>	2.8	0.8
	20	<b>GT19 L 20UN</b>	2.8	1.0

## Product Identification - Toolholders

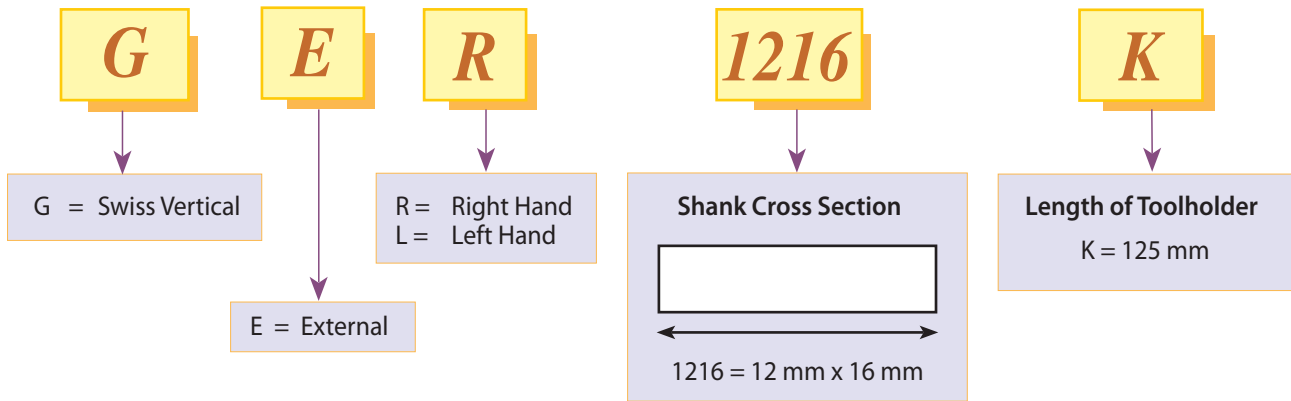

## External Toolholders

- Coolant through toolholders, for external turning in Swiss style lathes.
- The high pressure coolant is directed towards the insert cutting edge in order to evacuate the chips created and avoid build up edge.
- Including a coolant connector for a quick setup on the machine.

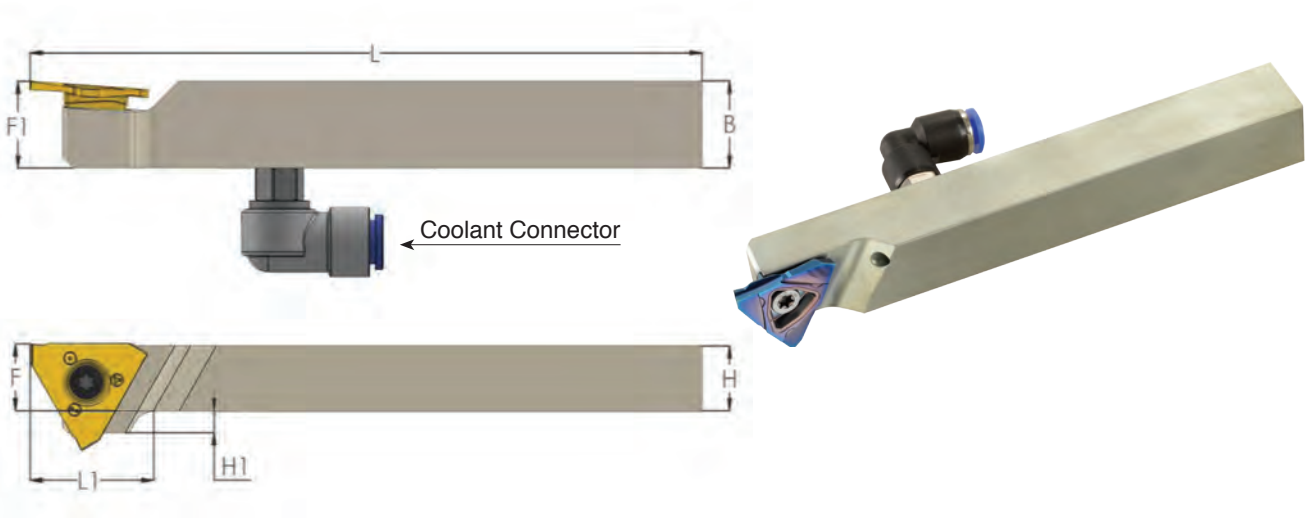

## Right hand

Ordering Code	B	H	L1	L	F	F1	H1	Insert Screw	Torx Key	*Coolant connector
** GER 0816 K	16	8	17	125	8	16	8	S21	K21	-
GER 1016 K	16	10	17	125	10	16	6	S21	K21	Ø4 / Ø6
GER 1216 K	16	12	17	125	12	16	4	S21	K21	Ø4 / Ø6
GER 1616 K	16	16	-	125	16	16	0	S21	K21	Ø4 / Ø6
GER 2020 K	20	20	-	125	20	20	0	S21	K21	Ø4 / Ø6
GER 2525 M	25	25	-	150	25	25	0	S21	K21	Ø4 / Ø6

\* Diameter of coolant pipe

\*\* Without coolant

## Left hand

Ordering Code	B	H	L1	L	F	F1	H1	Insert Screw	Torx Key	*Coolant connector
** GEL 0816 K	16	8	17	125	8	16	8	S21	K21	-
GEL 1016 K	16	10	17	125	10	16	6	S21	K21	Ø4 / Ø6
GEL 1216 K	16	12	17	125	12	16	4	S21	K21	Ø4 / Ø6
GEL 1616 K	16	16	-	125	16	16	0	S21	K21	Ø4 / Ø6
GEL 2020 K	20	20	-	125	20	20	0	S21	K21	Ø4 / Ø6
GEL 2525 M	25	25	-	150	25	25	0	S21	K21	Ø4 / Ø6

\* Diameter of coolant pipe

\*\* Without coolant

## Grooving - Parting Off - Turning - Profiling - Threading Working Method

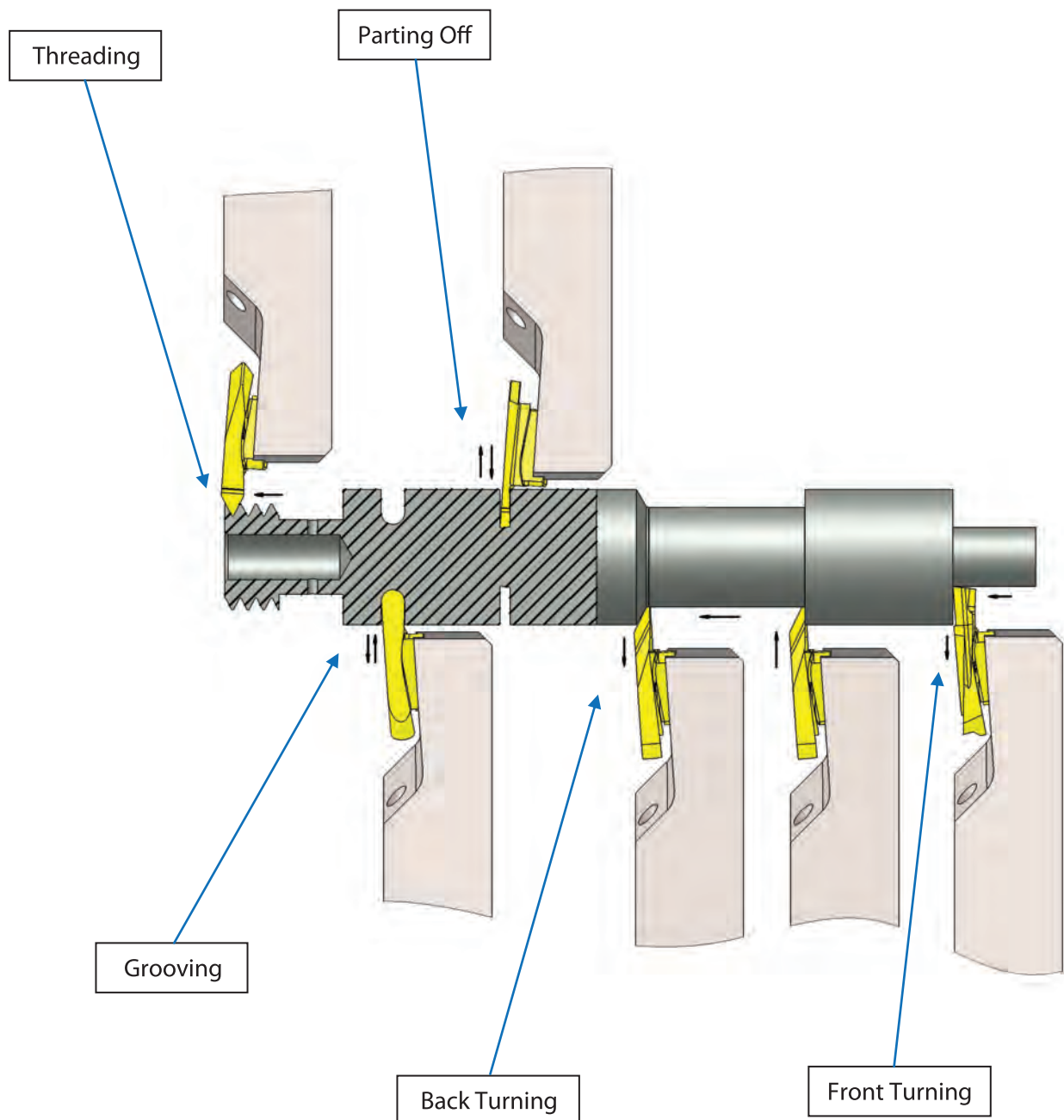

# Carbide Grades

## BLU

PVD triple layer coated Sub-Micron grade for Steel, Stainless Steels, Titanium and hard materials.

## K20

Uncoated Sub-Micron carbide grade for Aluminum and non-ferrous materials, Stainless Steels and Titanium.

ISO Standard	Materials	Cutting Speed m/min	
		K20	BLU
<b>P</b>	Low & Medium Carbon Steels <0.55%C	-	80-150
	High Carbon Steels ≥0.55%C	-	70-120
	Alloy Steels, Treated Steels	-	40- 80
<b>M</b>	Stainless Steel-Free Cutting	30- 80	60-120
	Stainless Steel-Austenitic	20- 70	30- 90
	Cast Steels	30- 80	50-120
<b>K</b>	Cast Iron	50-120	-
<b>N</b>	Aluminum ≤12%Si, Copper	120-250	-
	Aluminum >12%Si	90-200	-
	Synthetics, Duroplastics, Thermoplastics	70-150	-
<b>S</b>	Nickel Alloys, Titanium Alloys	20- 50	30- 70
<b>H</b>	Hardened Steel, 45-50HRc	-	20- 50