

## MPR серия Профильное точение и расточка

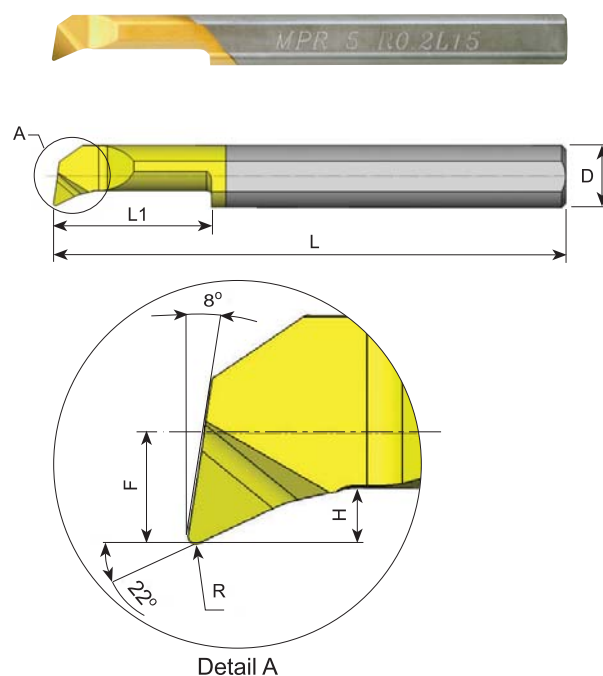
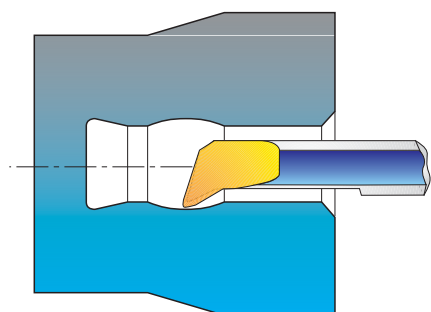

D	Код заказа	L	L1	R	H	F	Минимальный обрабатываемый диаметр	Оправка *
3.0	<b>MPR 1 R0.05 L4</b>	39	4	0.05	0.2	0.5	1.0	SIM 0020 H3
3.0	<b>MPR 1.5 R0.10 L6</b>	39	6	0.10	0.3	0.7	1.5	SIM 0020 H3
3.0	<b>MPR 2 R0.15 L5</b>	39	5	0.15	0.5	0.8	2.1	SIM 0020 H3
3.0	<b>MPR 2 R0.15 L10</b>	39	10	0.15	0.5	0.8	2.1	SIM 0020 H3
3.0	<b>MPR 3 R0.05 L10</b>	39	10	0.05	0.7	1.3	3.1	SIM 0020 H3
3.0	<b>MPR 3 R0.05 L15</b>	39	15	0.05	0.7	1.3	3.1	SIM 0020 H3
3.0	<b>MPR 3 R0.2 L10</b>	39	10	0.20	0.7	1.3	3.1	SIM 0020 H3
3.0	<b>MPR 3 R0.2 L15</b>	39	15	0.20	0.7	1.3	3.1	SIM 0020 H3
4.0	<b>MPR 4 R0.2 L10</b>	50	10	0.20	0.8	1.7	4.1	SIM 0020 H4
4.0	<b>MPR 4 R0.2 L15</b>	50	15	0.20	0.8	1.7	4.1	SIM 0020 H4
5.0	<b>MPR 5 R0.2 L15</b>	50	15	0.20	1.2	2.1	5.1	SIM 0020 H5
5.0	<b>MPR 5 R0.2 L22</b>	50	22	0.20	1.2	2.1	5.1	SIM 0020 H5
6.0	<b>MPR 6 R0.2 L15</b>	50	15	0.20	1.4	2.8	6.1	SIM 0020 H6
6.0	<b>MPR 6 R0.2 L22</b>	50	22	0.20	1.4	2.8	6.1	SIM 0020 H6
8.0	<b>MPR 8 R0.2 L15</b>	63	15	0.20	1.6	3.8	8.1	SIM 0020 H8
8.0	<b>MPR 8 R0.2 L22</b>	63	22	0.20	1.6	3.8	8.1	SIM 0020 H8
10.0	<b>MPR 10 R0.2 L35</b>	72	35	0.20	2.0	4.8	10.1	SIM 0020 H10

Пример заказа: MPR 4 R0.2 L15 BXC

Для заказа левого инструмента указывайте в обозначении MPL, вместо MPR

\*Другие оправки смотрите на странице 141