

Подсистема вспомогательного инструмента с цилиндрическим хвостовиком

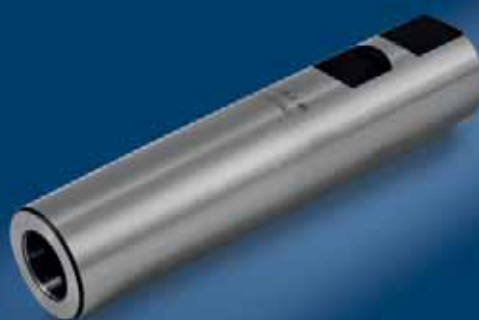

Оглавление

Патрон цанговый

Удлинитель для закрепления
инструмента с помощью термозажима

Фрезерные оправки для фрез
с резьбовым хвостовиком

Удлинитель и переходники для фрез
с резьбовым хвостовиком

Оправки для дисковых фрез



Патрон цанговый с цилиндрическим хвостовиком и сквозным отверстием

под цанги типа ER по DIN 6499

Номер по каталогу	d	Диапазон зажимаемых диаметров d, мм	L	L1	D
new 120.02.07	16	ER 11 1 - 7	100	24,5	16
new 120.02.07.1	16	ER 11 1 - 7	150	24,5	16

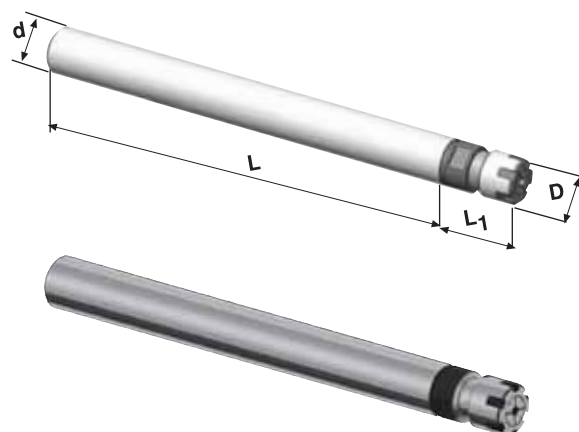

В комплект поставки входит: гайка зажимная

Комплектующие

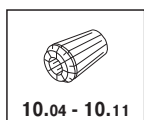

10.04 - 10.11

Цанги ER по DIN 6499

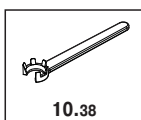

10.38

Ключ ER



10.14

Гайка зажимная

Патрон цанговый с цилиндрическим хвостовиком

под цанги типа ER по DIN 6499

Номер по каталогу	d	Диапазон зажима	L	L1	D
120.02.10	16	ER16 1 - 10	150	30	32
120.02.16	20	ER25 2 - 16	150	40	42
120.02.20	32	ER32 2 - 20	150	35	50

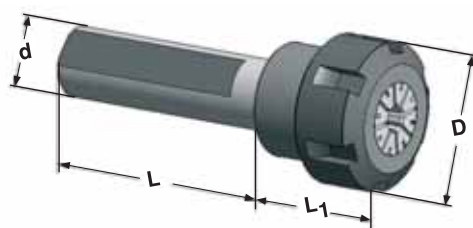

В комплект поставки входит: гайка зажимная

Комплектующие

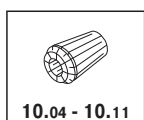

10.04 - 10.11

Цанги ER по DIN 6499

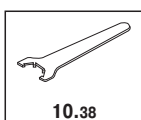

10.38

Ключ ER



10.15, 10.17

Гайка зажимная

Номер по каталогу	D	d1	d2	A	L1	L2	L3	M
120.25.12.03	12	3	8	150	-	-	12	M5
120.25.12.04	12	4	8	150	-	-	16	M5
120.25.16.03	16	3	10	150	-	-	12	M5
120.25.16.04	16	4	10	150	-	-	16	M5
120.25.16.05	16	5	10	150	-	-	20	M6
120.25.16.06	16	6	10	150	36	10	26	M5
120.25.20.03	20	3	10	150	-	-	12	M5
120.25.20.04	20	4	10	150	-	-	16	M5
120.25.20.05	20	5	10	150	-	-	20	M6
120.25.20.06	20	6	10	150	36	10	26	M5
120.25.20.08	20	8	12	150	36	10	26	M6
120.25.20.10	20	10	14	150	42	10	32	M6
120.25.20.12	20	12	16	150	47	10	37	M10
120.25.25.08	25	8	20	150	36	10	26	M6
120.25.25.10	25	10	20	150	42	10	32	M6
120.25.25.12	25	12	20	150	47	10	37	M10
120.25.25.14	25	14	20	150	47	10	37	M10
120.25.25.16	25	16	22	150	50	10	40	M10
120.25.32.10	32	10	24	150	42	10	32	M6
120.25.32.12	32	12	24	150	47	10	37	M10
120.25.32.14	32	14	27	150	47	10	37	M10
120.25.32.16	32	16	27	150	50	10	40	M10
120.25.32.18	32	18	27	150	50	10	40	M10
120.25.32.20	32	20	27	150	52	10	42	M10

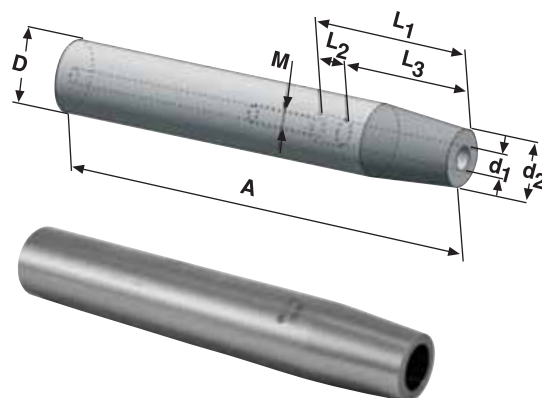

INFO

Техническая информация

11.06



для фрез с резьбовым хвостовиком

Номер по каталогу	D	M	d1	d2	d3	A	L
120.12.12.520	12	M5	5,5	10	12	20	65
120.12.06	20	M6	6,5	10	18	25	75
120.12.06.1	20	M6	6,5	10	18	50	100
120.12.06.2	20	M6	6,5	10	18	75	125
120.12.16.840	16	M8	8,5	13	16	40	88
120.12.08	20	M8	8,5	13	18	25	75
120.12.08.1	20	M8	8,5	13	18	50	100
120.12.08.2	20	M8	8,5	13	18	75	125
120.12.10	20	M10	10,5	18	18	25	75
120.12.20.1025	20	M10	10,5	18,5	20	25	80
120.12.10.1	20	M10	10,5	18	18	50	100
120.12.10.2	20	M10	10,5	18	18	75	125
120.12.20.1097	20	M10	10,5	18,5	20	97	152
120.12.12	25	M12	12,5	21	25	25	81
120.12.25.1240	25	M12	12,5	23	25	40	101
120.12.12.2	25	M12	12,5	21	25	75	131
120.12.25.12109	25	M12	12,5	23	25	109	170
120.12.12.4	25	M12	12,5	21	25	125	181
120.12.32.12105	32	M12	12,5	23	25	105	170
120.12.16	32	M16	17	29	32	25	85
120.12.32.1640	32	M16	17	30	32	40	105
120.12.16.2	32	M16	17	29	32	75	135
120.12.16.4	32	M16	17	29	32	125	185

Номер по каталогу	D	M	d1	d2	L1	A	L
123.12.20.1067	20	M10	10,5	18,5	67	68,7	160
123.12.25.1277	25	M12	12,5	23	77	87,5	240
123.12.32.1254	32	M12	12,5	23	23	54	160
123.12.32.12134	32	M12	12,5	23	59,5	134	300
123.12.32.1666	32	M16	17	30	66	68,7	160
123.12.32.16146	32	M16	17	30	146	148,7	300

Рекомендуемый момент затяжки

M6	10 Nm
M8	25 Nm
M10	40 Nm
M12	60 Nm
M16	80 Nm

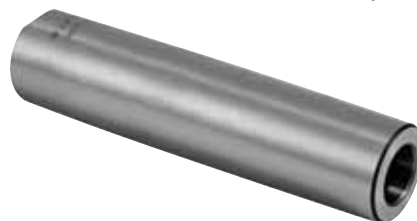
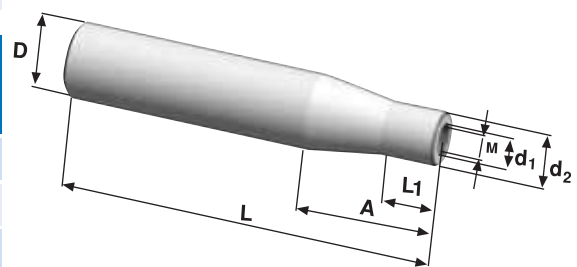
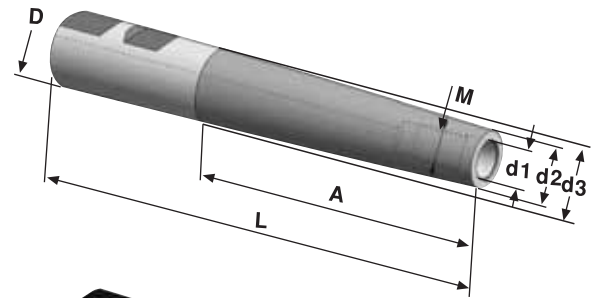

для фрез с резьбовым хвостовиком

Номер по каталогу	D	M	d1	L
124.12.8	13,5	M8	8,5	30
124.12.10	18,5	M10	10,5	35
124.12.12	23	M12	12,5	40
124.12.16	30	M16	17	40

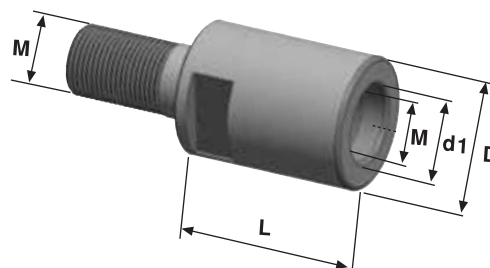

Номер по каталогу	D	M x M1	d1	d2	d3	L
126.12.58	13	M5 / M8	5,5	10	8,5	30
126.12.810	18,5	M8 / M10	8,5	13,5	10,5	30
126.12.1012	23	M10 / M12	10,5	18,5	12,5	35
126.12.1016	30	M10 / M16	10,5	18,5	17	60
126.12.1216	30	M12 / M16	12,5	23	17	60

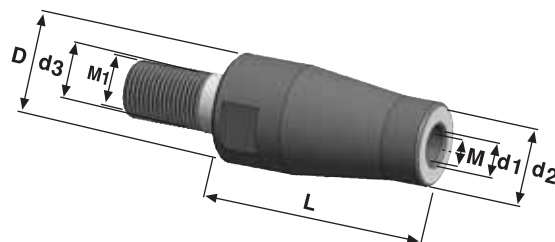

Рекомендуемый момент затяжки

M6	10 Nm
M8	25 Nm
M10	40 Nm
M12	60 Nm
M16	80 Nm



для инструмента с хвостовиком типа "Whistle Notch" по DIN 1835-E

Номер по каталогу	Размеры	d	d1	D	L1
122.20.06	20 - 06	20	6	25	30
122.20.08	20 - 08	20	8	28	30
122.20.10	20 - 10	20	10	35	30
122.20.12	20 - 12	20	12	42	35

122.32.06	32 - 06	32	6	25	30
122.32.08	32 - 08	32	8	28	30
122.32.10	32 - 10	32	10	35	30
122.32.12	32 - 12	32	12	42	35
122.32.14	32 - 14	32	14	44	35
122.32.16	32 - 16	32	16	48	38
122.32.18	32 - 18	32	18	50	38
122.32.20	32 - 20	32	20	52	40

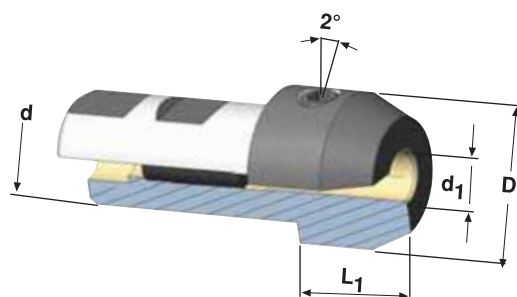

Комплектующие

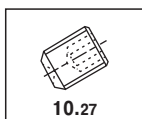

10.27

Винт зажимной

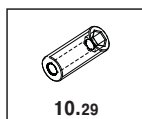

10.29

Винт регулировочный

Оправка

для дисковых фрез

Номер по каталогу	Размеры	Диаметр фрезы	D	d1	d	A	L
121.10.05	20 - 05	20	20	10	5	40	90
121.10.08	20 - 08	25 / 32	20	13	8	55	105
121.10.10	20 - 10	40	20	20	10	60	110
121.10.13	25 - 13	50	25	25	13	80	135
121.10.16	25 - 16	63	25	25	16	80	135

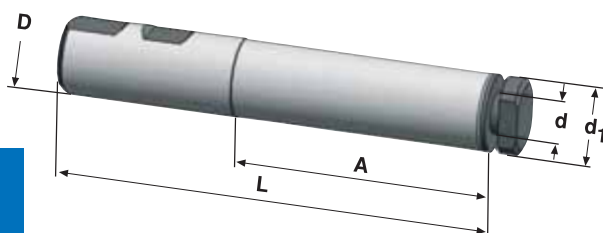

В комплект входит: винт зажимной и промежуточное кольцо
Может устанавливаться в оправки для концевых фрез и цанговые патроны