

# ZERO-POINT-SYSTEMS



CLAMPING. SCREWING. LOCKING.

**NEW: With large automation part**



## WE GENERATE EXCITEMENT.

Since its founding by Andreas Maier in 1890, our company has lived through many exciting times. Today we are the leading manufacturer in Europe, supplying over 5,000 different products from the fields of clamping, screwing and locking. With this extensive product range we can meet all of our customers' needs and requirements. But providing optimal quality means meeting the challenges at all levels: Expert consultation, modern team organisation, individual solutions (including special developments), flexibility in response to changing conditions, etc. And we ourselves find this so exciting that we look forward every day to shaping the market together with our employees and our customers – both now and in the future. That is something you can count on.

### COMPANY HISTORY

- 1890** Company founded by Andreas Maier as a lock manufacturer.
- 1920** Production program extended to include spanners.
- 1928** Production-line assembly of „FELLBACH LOCKS“.
- 1951** With the introduction of clamping elements, AMF diversified into the fields of workpiece and tool clamping.
- 1965** Toggle clamps extend the AMF product range. AMF catalogues are now published in ten languages.
- 1975** Hydraulic clamping marks further specialisation.
- 1982** Clamping and fixture systems round off AMF's clamping expertise.
- 1996** Introduction of the AMF Team Organisation in all business sectors. Quality assurance certified to ISO 9001.
- 2001** Introduction of the AMF Service Guarantee for all products.
- 2004** Introduction of the ZPS zero-point clamping system.
- 2007** The TTEC clamping system for automated welding and magnetic clamping technology extend the AMF product range.



#### 5 Individual development

You cannot find the product you need? Talk to us; we will find the right solution for you – from a special version, right through to a completely new development.

#### 4 Warranty

We believe in the high quality of our products. Complaints are dealt with quickly, unbureaucratically and generously – as far as possible, even well-beyond the guarantee period.

#### 3 Certified quality

AMF stands for painstaking production in our own works. We have followed this tradition since 1890 – today, of course, with a modern quality assurance system to ISO 9001.

#### 2 Short delivery times

From the AMF finished-product stores with over 5.000 articles, we can supply 98 % of orders from stock. And you can be sure that every stock article ordered is dispatched the same day.

#### 1 Real technical advice

Many tasks and a multitude of solutions. From AMF Professional Products you can find the right way to solve your problem – fast and reliably – either at your local dealer or with the help of the specialist in our team. Just call us!

#### E Made in Germany

It goes without saying that our range of products is developed and manufactured by our team of employees in Germany.

#### MANAGING DIRECTORS

> Volker Göbel  
Johannes Maier  
Hans-Günther Maier

#### THE AMF SERVICE GUARANTEE

> Assuredly on the way to the top

<b>ZERO-POINT - THE ZERO-POINT CLAMPING SYSTEM</b>	4 - 12
<b>INSTALLATION CLAMPING MODULES</b>	13 - 20
	
<b>SURFACE-MOUNTING CLAMPING MODULES</b>	21 - 25
	
<b>HORIZONTAL RAPID-CLAMPING CYLINDERS COMPACT CYLINDERS</b>	26 - 31
	
<b>AUTOMATION SOLUTIONS FROM AMF</b>	32 - 39
	
<b>HYDRAULIC CLAMPING STATIONS QUICK-CHANGE PALLETS</b>	40 - 45
	
<b>CLAMPING NIPPLES AND ENGAGEMENT NIPPLE SCREWS</b>	46 - 52
	
<b>ACCESSORIES - PRESSURE INTENSIFIERS, VALVES, HOSES</b>	53 - 61
	
<b>CLAMPING MODULES GONZALES AND UNITOOL FOR CONVERSION OF EXISTING CLAMPING SYSTEMS</b>	62 - 69
	
<b>CONTENTS</b>	70



## **ECONOMICAL, PRECISE, QUICK** - THE AMF ZERO-POINT SYSTEM

By using modern AMF zero-point systems, you optimize fixture and workpiece changeover in your production, correspondingly reducing set-up times on the machine and so save money!

The benefits of zero-point clamping technology are obvious:

- > Increase in machine run-time
- > Very fast workpiece or fixture changeover
- > High repeatability
- > A uniform interface for all machines
- > Positioning and clamping in a single step





> The clamping nipple in our zero-point system is the interface between the machine table and the workpiece or fixture. It ensures exact positioning and secure clamping. The resulting work forces are transferred through the clamping nipple to the clamping module.

> The precisely manufactured clamping modules of the AMF Zero-Point System ensure a secure and firm hold of the workpiece or fixture to be clamped. With their high pull-in, closing and holding forces, they are suitable for every application.

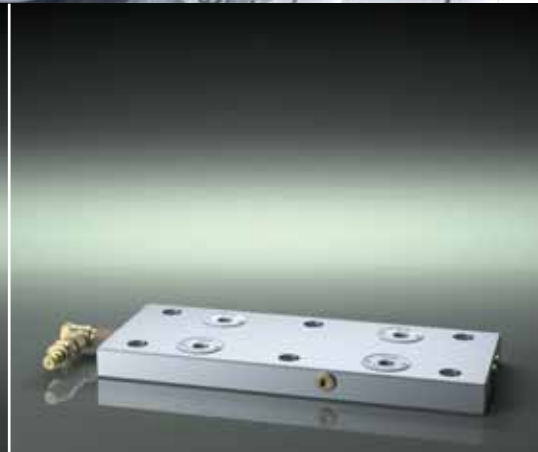

# YOUR ADVANTAGES - THOUGHT THROUGH

---

Experience a zero point clamping system that, through its innovative and forward-looking features, presents its strengths in use in an advanced way.

Numerous advantages speak for themselves and make the AMF zero-point system into a technology that revolutionizes the zero-point clamping technology market.

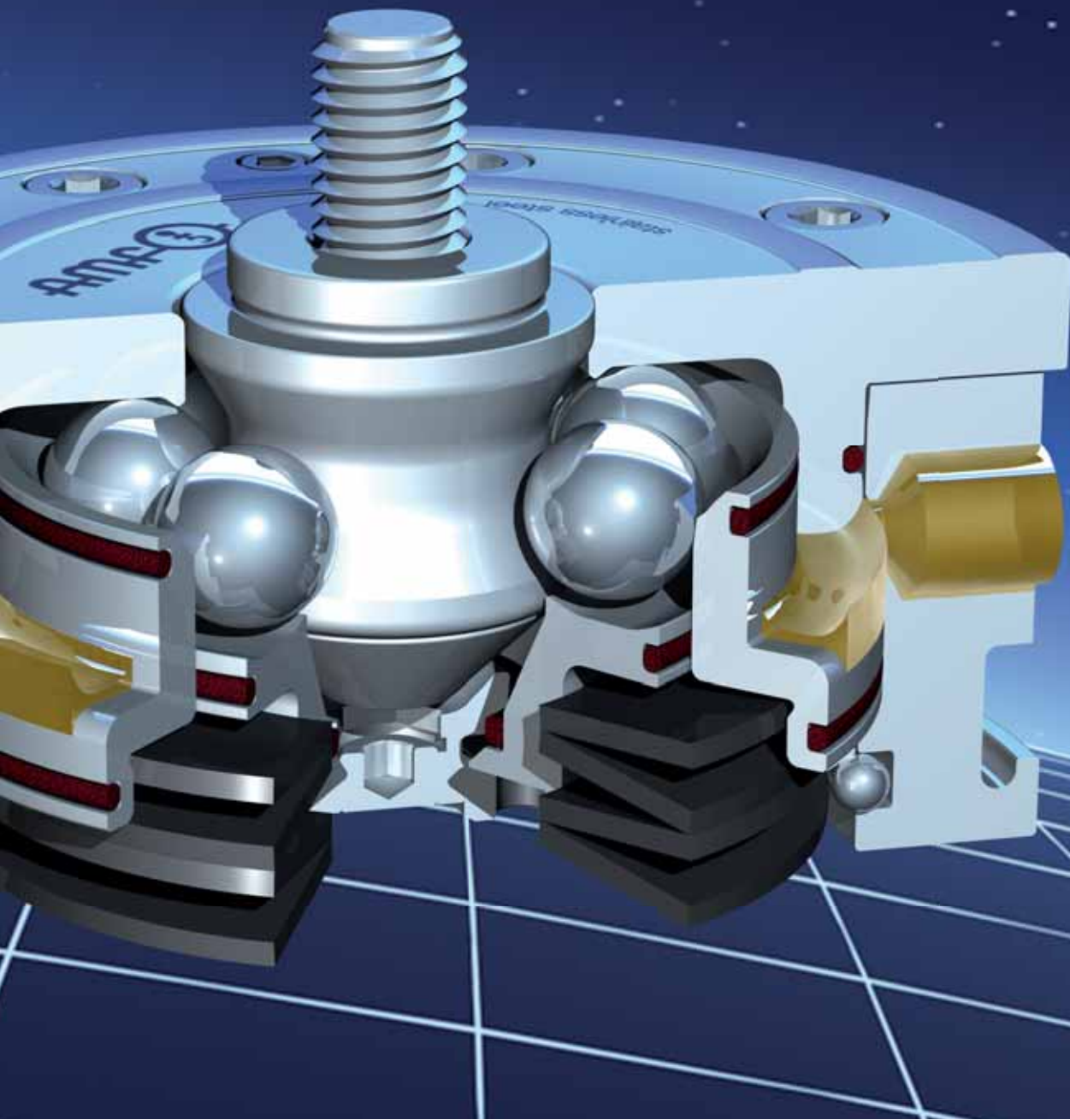

## LARGE INTAKE CATCHMENT



No laborious searching for the holes anymore - self-centring via the diagonal side surfaces of the engagement nipple screw.

## SWING-FREE



Swing-free run-in and run-out through the optimal contour of the clamping nipple.

## MEDIA FEED



Due to the lateral media feed, low pallet thicknesses are possible and fewer feed holes are necessary.

## FORM FIT



The balls are optimally encapsulated on 3 sides. As a result, the clamping nipple always remains firmly clamped in the module.

## THREE-POINT PRINCIPLE



Power transmission by means of the three-point principle! This optimised force distribution prevents shearing load on the balls.

## NO BALL CAGE



The balls lie freely in the ball canal. This freedom of movement enables the balls to continuously re-position themselves.

## RUSTPROOF STAINLESS STEEL



High-alloy, hardened tool steel - and so no corrosion.

## BLOW OUT



Our system has a pneumatic blow-out installed at the factory. As a result, chips and dirt inside are effectively blown out.

## SIMPLE CLEANING



Our zero-point clamping systems can be blown out very simply with a commercially available compressed air cleaning pistol and do not require complicated suctioning out.

## GOOD HOLDING, PULL-IN AND LOCKING FORCES



Size	Holding force [kN]	Pull-in/locking force [kN]	
		hyd.	pneum.
K 5	13	5	1,5
K10	25	10	8
K20	55	20	17
K40	105	40	30

## LARGE BALL DIAMETER



Ball surface is 784% greater than with traditional ball systems.

## SAFETY SYSTEM

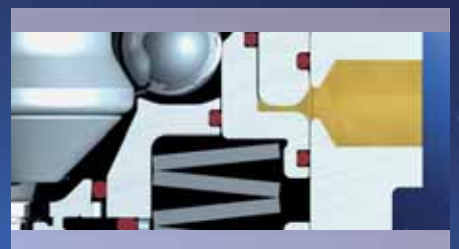

Process reliability - Clamping module always opens. A piston blockade is thus impossible.

# FAQ'S ABOUT ZERO-POINT CLAMPS AND THE AMF ZERO-POINT SYSTEM

## WHAT IS PULL-IN FORCE / HOLDING FORCE?

Size	Pull-in/locking force up to [kN]	Holding force [kN]
K10	10	25
K16	10	25
K19	30	55

- > The pull-in force describes the force with which the nipple is pulled in and clamped with positive interlocking in the clamping module. The holding force, in contrast, specifies the maximum permissible pull force of the engagement nipple screw.

## WHAT IS REPEATABILITY?

Pre-positioning	[mm]
Repeatability	[mm]

- > The repeatability specifies the tolerance range within which the recorded reference points on the workpiece lie after removal and reclamping of the same workpiece. The repeatability, also called repetition accuracy, is below 0.005mm.

## WHAT ADVANTAGES RESULT FROM THE USE OF ZERO-POINT, SLIT AND UNDERSIZE NIPPLES?

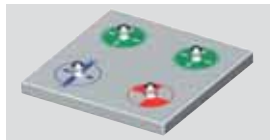

- > These different types of nipples offset the spacing tolerances of nipples and clamping modules. The fixed reference point is achieved through the zero-point nipple; the slit nipple serves to compensate for the still-free axis. The undersize nipple does not have a centring function, but only a clamping and holding function.

## CAN I INSERT THE CLAMPING NIPPLE DIRECTLY INTO THE WORKPIECE FOR MACHINE PROCESSING?



- > The high costs for chucking fixtures and workpiece clamping can be effectively saved here if the clamping nipples are mounted in the workpiece, which is clamped directly using the clamping modules. As a result, a complete 5-sided processing of the workpiece is possible in one chucking. With the different nipple sizes (attaching thread M6 to M16), workpieces of different sizes can be clamped.

## HOW DOES THE SYSTEM COMPENSATE FOR HEAT, SUCH AS FROM METAL CUTTING?

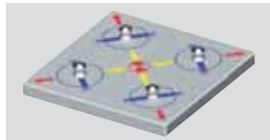

- > Through the different clamping nipple designs, the system can compensate for temperature differences between the workpiece and the clamping module easily and controllably. For a graphic depiction of the nipple array, see page 47 of the catalogue. If you have other technical questions, please contact us at any time.

## WHAT SHOULD BE THE SPACING TOLERANCE OF THE CLAMPING NIPPLES AND THE CLAMPING MODULES IF SELF-PRODUCED?

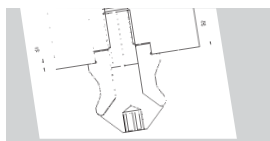

- > The recommended spacing tolerance of clamping nipples and clamping modules is +/- 0.01mm.



## WHERE CAN I GET AN INSTALLATION DIAGRAM?

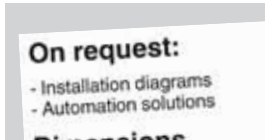

> We are happy to send them immediately when customers request them by e-mail.

## IS THE CLAMPING MODULE SUITABLE FOR ERODING?



> The module is optimally suited for all normal processes, such as eroding, grinding, cutting and turning. Through the complete sealing, the clamping module can be used in liquids and under rough ambient conditions.

## IS THE CLAMPING MODULE SUITABLE FOR USE ON INJECTION MOULDING MACHINES?



> Especially when injection moulds are changed frequently, the costs for a zero-point solution are amortized within the shortest of times for such machines. Unlike with mechanical clamps, clamping takes place with them quickly and easily just by pressing a button.

## HOW HIGH IS THE MAX. OPERATING TEMPERATURE OF THE CLAMPING MODULES?



> The maximum processing temperature is 80°C in the standard design. Clamping modules for use at higher temperatures can be requested at any time.

## WHAT IS BLOW-OUT AND HOW DOES IT WORK?

ig force kN]	Blow out	Weight [Kg]
25	-	0,45
25	✓	0,41
25		1,4

> Blow-out uses compressed air guided through the base of the clamping module to blow out contamination, such as chips, coolant etc. from the central opening and ball location groove.

## WHEN DO I USE THE HYDRAULIC PRESSURE INTENSIFIER AND WHEN THE PNEUMATIC PRESSURE INTENSIFIER?



> Hydraulic pressure intensifier: This transforms the pneumatic into hydraulic pressure in a ratio of 1:8 to open hydraulic modules. Pneumatic pressure intensifier: This is used to intensify the pneumatic pressure in the ratio of 1:2 for pneumatic clamping modules and compensates for pressure fluctuations in the supply line.

## HOW DOES THE PATENTED SAFETY SYSTEM WORK IN THE HYDRAULIC CLAMPING MODULE AND WHEN IS IT USED?



> If the piston seal begins to leak, the spring space quickly fills with oil. The result is: The piston locks and the module can no longer be opened. Damage to the clamped fixture and/or the clamping module would then be unavoidable. Here, the patented safety system ensures that the oil in the spring space can escape and the piston can be operated again.

# ARE YOU PRODUCING OR STILL SETTING UP?

## THE CALCULATION IS VERY SIMPLE!

It has been shown that you can reduce your set-up times by over 90% through the use of the AMF Zero-Point System. Machine set-up times are reduced, idle times are minimized and costs saved....

Take the time to see your savings potential with the AMF Zero-Point System using the simple calculation below.

### Sample calculation of a customer before and after use of the zero-point system.

Procedure	Without zero-point clamping system	With the AMF Zero Point System
Machine costs	€ 80,-- / h	€ 80,-- / h
Number of set-ups per day	4 x	4 x
Set-up time per procedure	30 min.	2 min.
Set-up time per day	120 min (2 h)	8 min. (0,13 h)
Set-up costs per day	€ 160,--	€ 10,67
Set-up costs per year with 240 work days	€38.400,--	€ 2.560,80
Annual savings	<b>€ 35.839,20</b>	

### Just run the figures!

Your cost-benefit calculation with your payback period for the Zero Point System.

Procedure	Without zero-point clamping system	With the AMF Zero Point System
Machine costs		
Number of set-ups per day		
Set-up time per procedure		
Set-up time per day		
Set-up costs per day		
Set-up costs per year with 240 work days		
Annual savings		
Investment for your Zero-Point System		

# COLOUR CODING SYSTEM FOR HYDRAULIC AND PNEUMATIC CLAMPING MODULES.

Table portion with bright ORANGE background: Open hydraulically!

Table portion with bright BLUE background: Open pneumatically!

	<b>K5</b> Cat. p. 14 and 22		<b>K10</b> Cat. p. 15-16 and 23-24		<b>K20</b> Cat. p. 15-16 and 23-24		<b>K40</b> Cat. p. 15-16 and 23-24	
	hyd.	pneum.	hyd.	pneum.	hyd.	pneum.	hyd.	pneum.
Pull-in/locking force in the system up to [kN]	5	1,5	10	8,5	20	17	40	30
Holding force [kN]	13	13	25	25	55	55	105	105
Service according to ... clamping cycles [pce]	150.000	150.000	150.000	150.000	150.000	150.000	150.000	150.000
Min./max. operating pressure for opening [bar]	50 / 60	8 / 12	50 / 60	8 / 12	50 / 60	8 / 12	50 / 60	8 / 12
Min./max. operating pressure for reclamping [bar]	-	5 / 6	-	5 / 6	-	5 / 6	-	5 / 6
Opening volume [cm <sup>3</sup> ]	1,5	1,5	3,0	3,0	10,0	10,0	27,0	27,0
Closing volume [cm <sup>3</sup> ]	-	-	-	-	-	-	-	-
Pre-positioning [mm]	4,0	4,0	6,5	6,5	12,0	12,0	12,0	12,0
Repeatability [mm]	< 0,005	< 0,005	< 0,005	< 0,005	< 0,005	< 0,005	< 0,005	< 0,005

	<b>Horizontal K20</b> Cat. p. 26	<b>Horizontal K40</b> Cat. p. 26	<b>Compact K10</b> Cat. p. 29	<b>Turbine K23</b> Cat. p. 38	<b>Heavy duty K20</b> Cat. p. 17
	hyd.	hyd.	hyd.	hyd.	hyd.
Pull-in/locking force in the system up to [kN]	20	40	13	23	20
Holding force [kN]	55	105	25	23	105
Service according to ... clamping cycles [pce]	150.000	150.000	150.000	150.000	150.000
Min./max. operating pressure for opening [bar]	50 / 60	50 / 60	50 / 60	20 / 40	50 / 60
Min./max. operating pressure for reclamping [bar]	-	-	-	20 / 25	-
Opening volume [cm <sup>3</sup> ]	10,0	27,0	3,5	7,5	10,0
Closing volume [cm <sup>3</sup> ]	-	-	-	10,7	-
Pre-positioning [mm]	11,0	11,0	4,0	1,0	12,0
Repeatability [mm]	< 0,005	< 0,005	< 0,005	< 0,005	< 0,005



Subject to technical alterations.

## INSTALLATION CLAMPING MODULES

The AMF installation clamping modules are used with low space requirement and low overall height. For installation in pallets, machine tables, clamping brackets and cubes. Usable when cutting, grinding, eroding and on plastic-processing machines as well as for fixture construction with mounting fixtures and handling systems. The AMF clamping modules can be installed in all positions. Whether vertical or overhead - installation does not require any special assembly tools.

Installation clamping modules are available in four different sizes:

- > **Clamping modules K40** - dia. 148 mm -  
pull-in/locking force up to 40 kN - holding force 105 kN
- > **Clamping modules K20** - dia. 112 mm -  
pull-in/locking force up to 20 kN - holding force 55 kN
- > **Clamping modules K10** - dia. 78 mm -  
pull-in/locking force up to 10 kN - holding force 25 kN
- > **Clamping modules K5** - dia. 45 mm -  
pull-in/locking force up to 5 kN - holding force 13 kN



## No. 6370EARH

### Installation clamping module, round, screw-in version

Hydraulic opening.  
Opening operating pressure: min. 50 bar - max. 60 bar  
Cover and piston hardened.  
Repeatability < 0.005 mm.



STAINLESS STEEL

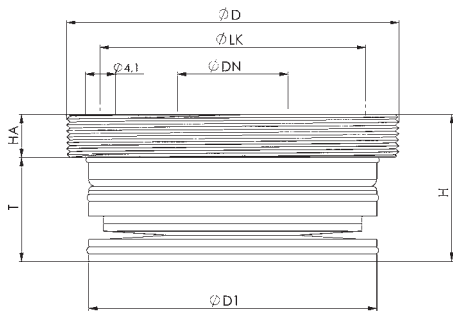

Order no.	Size	Pull-in/locking force up to [kN]	Holding force [kN]	Weight [g]
305953	K 5	5	13	300

#### Application:

Zero-point clamping system for set-up-time-optimized clamping with cutting and non-cutting processing in all areas, also in the food, pharmaceutical and chemical industry. With small space requirement and low overall height.

#### Note:

The installation clamping module has high holding, pull-in and locking forces. This is opened hydraulically (1) and mechanically locked through spring force. Subsequent uncoupling of the pressure lines is possible at all times (module is tensioned pressure-free).

The contact surface is the upper surface of the housing.  
Clamping module has one connection: 1x hyd. opening (1).  
Matching mounting tool is available under the AMF order no. 41046.

#### On request:

- Installation diagrams

#### Dimensions

Order no.	Size	dia. D	dia. DN	dia. D1	H	HA	dia. LK	T
305953	K 5	M45 x 1	15	39	19,8	5,8	36	14

## No. 6370EARL

### Installation clamping module, round, screw-in version

Pneumatic opening.  
Opening operating pressure: min. 8 bar - max. 12 bar  
Retensioning operating pressure (turbo): min. 5 bar - max. 6 bar  
Cover and piston hardened.  
Repeatability < 0.005 mm.



STAINLESS STEEL

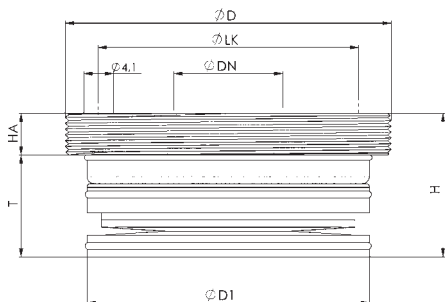

Order no.	Size	Pull-in/locking force up to [kN]	Holding force [kN]	Weight [g]
305979	K 5	1,5	13	300

#### Application:

Zero-point clamping system for set-up-time-optimized clamping with cutting and non-cutting processing in all areas, also in the food, pharmaceutical and chemical industry. With small space requirement and low overall height.

#### Note:

The installation clamping module has high holding, pull-in and locking forces. This is opened pneumatically (1) and mechanically locked through spring force. To achieve the specified pull-in and locking forces, it must be briefly retensioned pneumatically (turbo) (2). Subsequent uncoupling of the pressure lines is possible at all times (module is tensioned pressure-free). The contact surface is the upper surface of the housing. Use of the pneumatic pressure booster (cat. p. 57) is recommended.

Clamping module has two connections:  
1x pneum. opening (1) / 1x pneum. retensioning (turbo) (2).  
Matching mounting tool is available under the AMF order no. 41046.

#### On request:

- Installation diagrams

#### Dimensions

Order no.	Size	dia. D	dia. DN	dia. D1	H	HA	dia. LK	T
305979	K 5	M45 x 1	15	39	19,8	5,8	36	14

## No. 6370EARH

### Installation clamping module, round

Hydraulic opening.  
Opening operating pressure: min. 50 bar - max. 60 bar  
Cover and piston hardened.  
Repeatability < 0.005 mm.



STAINLESS STEEL

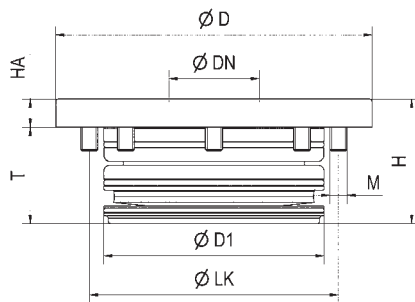
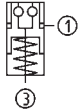

Order no.	Size	Pull-in/locking force up to [kN]	Holding force [kN]	Blow out	Weight [Kg]
303628	K10	10	25	-	0,45
305367	K10	10	25	√	0,45
302984	K20	20	55	-	1,40
302992	K20	20	55	√	1,40
303024	K40	40	105	-	3,45
303032	K40	40	105	√	3,40

#### Application:

Zero-point clamping system for set-up-time-optimized clamping with cutting and non-cutting processing in all areas, also in the food, pharmaceutical and chemical industry.

#### Note:

The installation clamping module has high holding, pull-in and locking forces. This is opened hydraulically (1) and mechanically locked through spring force. Subsequent uncoupling of the pressure lines is possible at all times (module is tensioned pressure-free).

Clamping module has one connection: 1x hyd. opening (1).

Clamping module with blow-out has two connections:

1x hyd. opening (1) / 1x pneum. blow-out (3).

Installation clamping module in flange version for simplified installation, see cat. p. 19.

#### On request:

- Installation diagrams
- Automation solutions

#### Dimensions

Order no.	Size	dia. D	dia. DN	dia. D1	H	HA	dia. LK	M	T
303628	K10	78	22	50	30	7	60	M5	23
305367	K10	78	22	50	30	7	60	M5	23
302984	K20	112	32	78	44	10	88	M6	34
302992	K20	112	32	78	44	10	88	M6	34
303024	K40	148	40	102	57	15	118	M8	42
303032	K40	148	40	102	57	15	118	M8	42

## No. 6370EARL

### Installation clamping module, round

Pneumatic opening.  
Opening operating pressure: min. 8 bar - max. 12 bar  
Retensioning operating pressure (turbo): min. 5 bar - max. 6 bar  
Cover and piston hardened.  
Repeatability < 0.005 mm.



STAINLESS STEEL

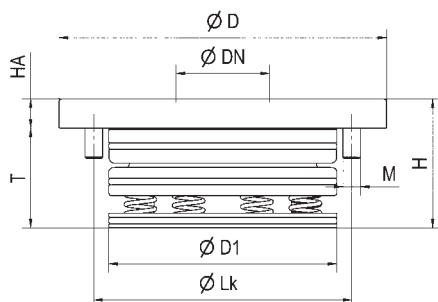
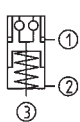

Order no.	Size	Pull-in/locking force up to [kN]	Holding force [kN]	Blow out	Weight [Kg]
303602	K10	8	25	-	0,45
305375	K10	8	25	√	0,45
303008	K20	17	55	-	1,40
303016	K20	17	55	√	1,40
303040	K40	30	105	-	3,45
303057	K40	30	105	√	3,40

#### Application:

Zero-point clamping system for set-up-time-optimized clamping with cutting and non-cutting processing in all areas, also in the food, pharmaceutical and chemical industry.

#### Note:

The installation clamping module has high holding, pull-in and locking forces. This is opened pneumatically (1) and mechanically locked through spring force. To achieve the specified pull-in and locking forces, it must be briefly retensioned pneumatically (turbo) (2). Subsequent uncoupling of the pressure lines is possible at all times (module is tensioned pressure-free). Use of the pneumatic pressure booster (cat. p. 57) is recommended.

The clamping module has two connections:

1x pneum. opening (1) / 1x pneum. retensioning (turbo) (2).

Clamping module with blow-out has three connections:

1x pneum. opening (1) / 1x pneum. retensioning (turbo) (2), 1x pneum. blow-out (3).

Installation clamping module in flange version for simplified installation, see cat. p. 19.

#### On request:

- Installation diagrams
- Automation solutions

#### Dimensions

Order no.	Size	dia. D	dia. DN	dia. D1	H	HA	dia. LK	M	T
303602	K10	78	22	50	30	7	60	M5	23
305375	K10	78	22	50	30	7	60	M5	23
303008	K20	112	32	78	44	10	88	M6	34
303016	K20	112	32	78	44	10	88	M6	34
303040	K40	148	40	102	57	15	118	M8	42
303057	K40	148	40	102	57	15	118	M8	42

Subject to technical alterations.

## No. 6370EAQH

### Installation clamping module, square

Hydraulic opening.  
Opening operating pressure: min. 50 bar - max. 60 bar  
Cover and piston hardened.  
Repeatability < 0.005 mm.

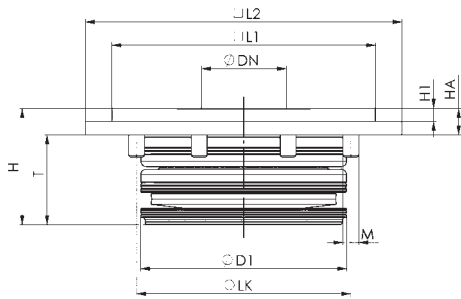
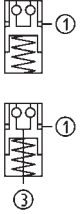

Order no.	Size	Pull-in/locking force up to [kN]	Holding force [kN]	Blow out	Weight [Kg]
305243	K10	10	25	-	0,55
305250	K10	10	25	✓	0,55
305268	K20	20	55	-	1,70
305276	K20	20	55	✓	1,70
305284	K40	40	105	-	3,60
305292	K40	40	105	✓	3,55

### Application:

Zero-point clamping system for set-up-time-optimized clamping with cutting and non-cutting processing in all areas, also in the food, pharmaceutical and chemical industry. A square clamping module prevents the pallet from twisting. The indexing function enables exact positioning every 90°.

### Note:

The installation clamping module has high holding, pull-in and locking forces. This is opened hydraulically (1) and mechanically locked through spring force. Subsequent uncoupling of the pressure lines is possible at all times (module is tensioned pressure-free).

Clamping module has one connection: 1x hyd. opening (1).

Clamping module with blow-out has two connections: 1x hyd. opening (1)/ 1x pneum. blow-out (3)

### On request:

- Installation diagrams
- Automation solutions

### Dimensions

Order no.	Size	dia. DN	dia. D1	H	HA	H1	L	L1	dia. LK	M	T
305243	K10	22	50	30	7	3,5	85	70	60	M5	23
305250	K10	22	50	30	7	3,5	85	70	60	M5	23
305268	K20	32	78	44	10	5,0	120	100	88	M6	34
305276	K20	32	78	44	10	5,0	120	100	88	M6	34
305284	K40	40	102	57	15	5,0	150	130	118	M8	42
305292	K40	40	102	57	15	5,0	150	130	118	M8	42

## No. 6370EAQL

### Installation clamping module, square

Pneumatic opening.  
Opening operating pressure: min. 8 bar - max. 12 bar  
Retensioning operating pressure (turbo): min. 5 bar - max. 6 bar  
Cover and piston hardened.  
Repeatability < 0.005 mm.

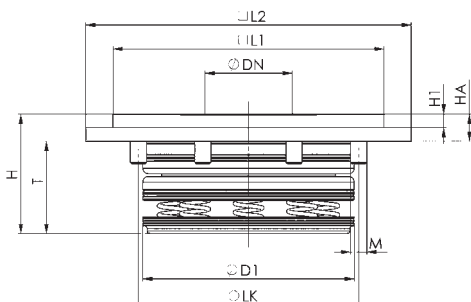
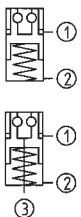

Order no.	Size	Pull-in/locking force up to [kN]	Holding force [kN]	Blow out	Weight [Kg]
305300	K10	8	25	-	0,55
305318	K10	8	25	✓	0,55
305326	K20	17	55	-	1,85
305334	K20	17	55	✓	1,80
305342	K40	30	105	-	3,45
305359	K40	30	105	✓	3,40

### Application:

Zero-point clamping system for set-up-time-optimized clamping with cutting and non-cutting processing in all areas, also in the food, pharmaceutical and chemical industry. A square clamping module prevents the pallet from twisting. The indexing function enables exact positioning every 90°.

### Note:

The installation clamping module has high holding, pull-in and locking forces. This is opened pneumatically (1) and mechanically locked through spring force. To achieve the specified pull-in and locking forces, it must be briefly retensioned pneumatically (turbo) (2). Subsequent uncoupling of the pressure lines is possible at all times (module is tensioned pressure-free). Use of the pneumatic pressure booster (cat. p. 57) is recommended.

The clamping module has two connections:

1x pneum. opening (1) / 1x pneum. retensioning (turbo) (2).

Clamping module with blow-out has three connections:

1x pneum. opening (1) / 1x pneum. retensioning (turbo) (2), 1x pneum. blow-out (3).

### On request:

- Installation diagrams
- Automation solutions

### Dimensions

Order no.	Size	dia. DN	dia. D1	H	HA	H1	L	L1	dia. LK	M	T
305300	K10	22	50	30	7	3,5	85	70	60	M5	23
305318	K10	22	50	30	7	3,5	85	70	60	M5	23
305326	K20	32	78	44	10	5,0	120	100	88	M6	34
305334	K20	32	78	44	10	5,0	120	100	88	M6	34
305342	K40	40	102	57	15	5,0	150	130	118	M8	42
305359	K40	40	102	57	15	5,0	150	130	118	M8	42

Subject to technical alterations.



## No. 6201H

### Installation clamping module, heavy-duty, round

Hydraulic opening.  
Opening operating pressure: min. 50 bar - max. 60 bar  
Cover and piston hardened.  
Repeatability < 0.005 mm.

**NEW!**



STAINLESS STEEL

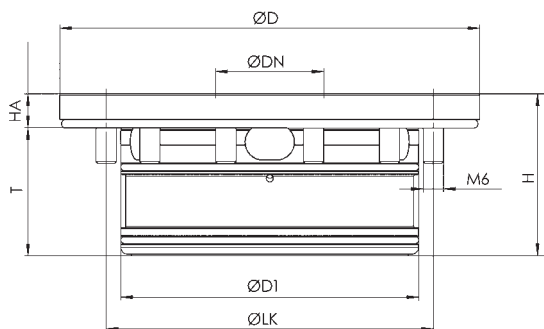

Order no.	Size	Pull-in/locking force up to [kN]	Holding force [kN]	Weight [Kg]
306084	K20	20	105	1,94

### Application:

Zero-point clamping system for set-up-time-optimized clamping with cutting and non-cutting processing in all areas, also in the food, pharmaceutical and chemical industry. The installed heavy-duty clamping module K20 has the same max. holding force as the clamping module K40. The example here is that the clamping nipple has the same outside dimensions as the clamping nipple in the clamping module K20. As a result, a uniform clamping nipple size can be achieved in all fixtures, and the same module size can be achieved on the machine tables.

### Note:

The heavy duty installation clamping module, despite small installation dimensions, has increased holding force through the reinforced design. Due to the cartridge construction, simplified installation in the body is possible. The clamping module is opened hydraulically (1) and mechanically locked through spring force. Subsequent uncoupling of the pressure lines is possible at all times (module is tensioned pressure-free). Clamping module has one connection: 1x hyd. opening (1).

### On request:

- Installation diagrams
- Automation solutions

### Dimensions

Order no.	Size	dia. D	dia. DN	dia. D1	H	HA	dia. LK	T
306084	K20	124	32	88	47,8	10	100	37,8

## MORE EXTREME HOLDING FORCES - WITH SAME INTERFACE

- 1 Heavy duty clamping modules for extreme processing forces
- 2 Clamping nipple K20 as the same interface between the two clamping modules
- 3 Clamping module K20 for all other applications

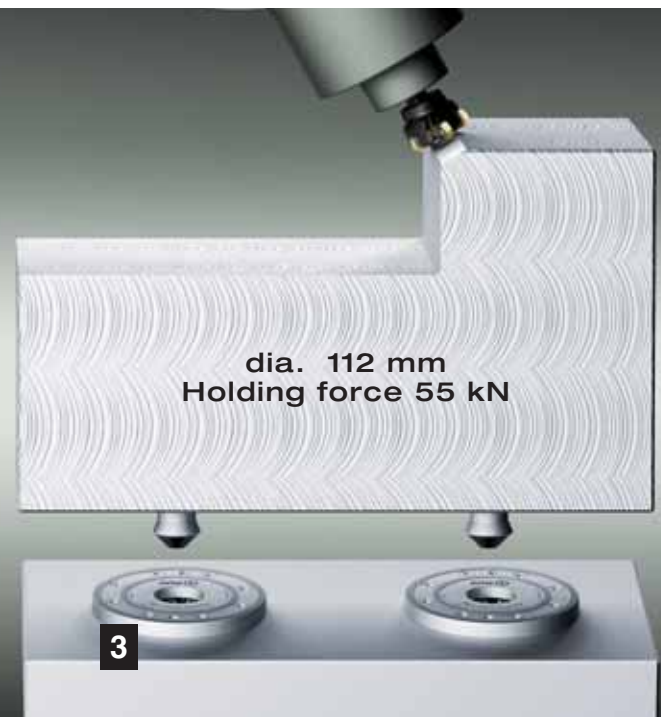

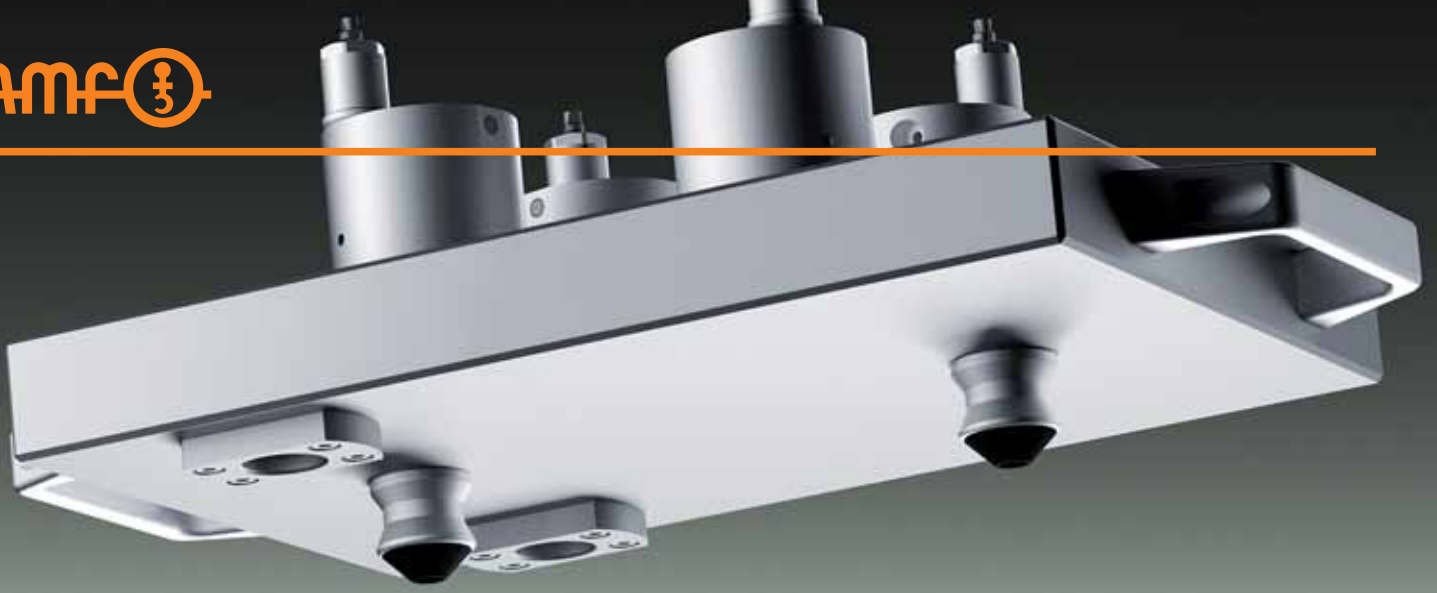

## SIMPLIFIED INSTALLATION IN THE PALLET

### - THE INSTALLATION CLAMPING MODULE AS FLANGE VERSION

The flange version of the installation clamping module has a centring ring on the underside. This allows simplified and precise installation of the module. The low depth of the mounting hole for the centring ring, means existing pallets and fixture plates can be easily and inexpensively retrofitted with the AMF Zero-Point System. The clamping module can be operated via a tube connection on the outside or from the bottom via an O-ring connection.

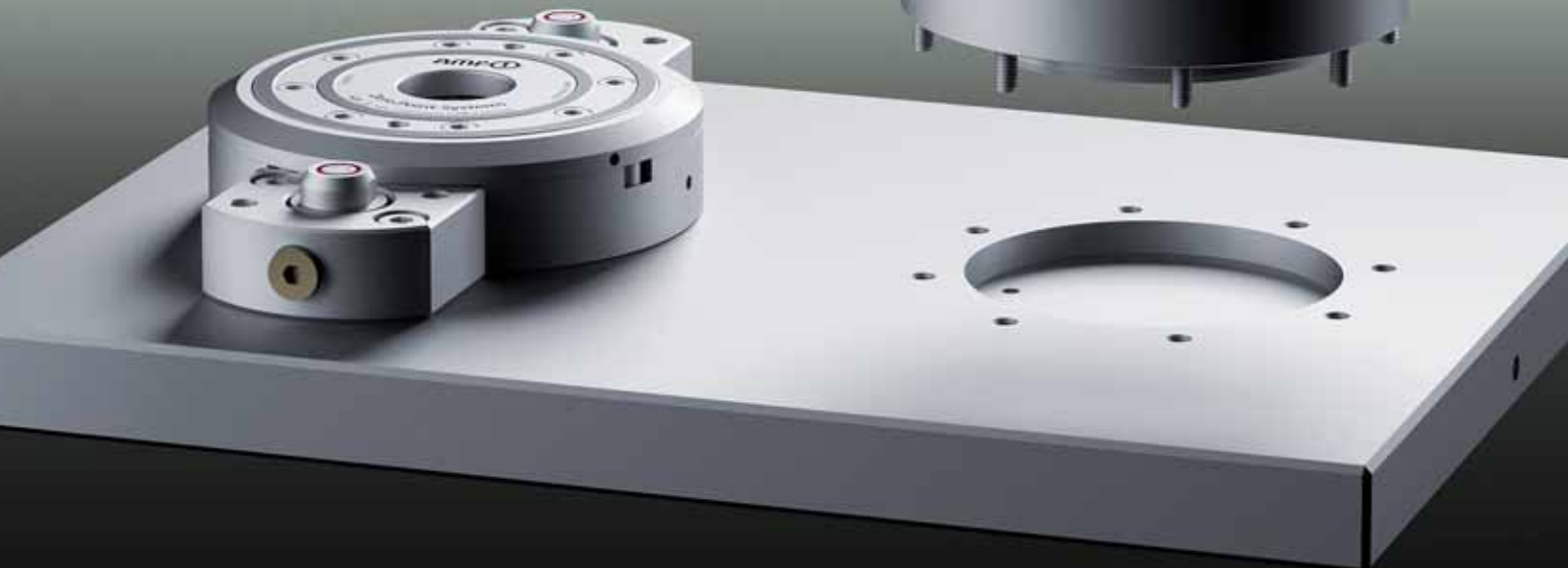
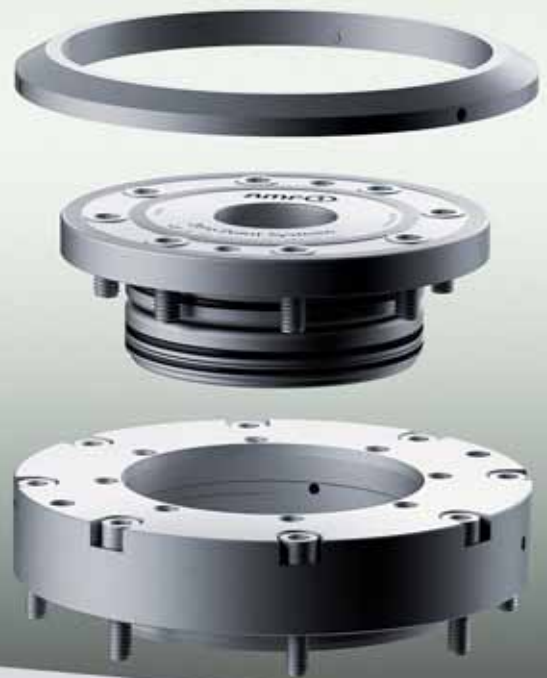

## No. 6151H

### Installation clamping module, round, flange version

Hydraulic opening.  
Opening operating pressure: min. 50 bar - max. 60 bar  
Cover and piston hardened.  
Repeatability < 0.005 mm.

**NEW!**



STAINLESS STEEL

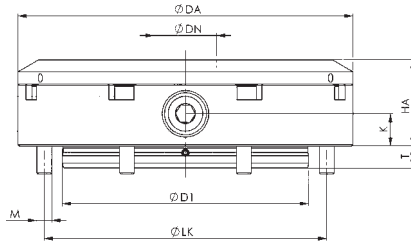
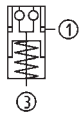

Order no.	Size	Pull-in/locking force up to [kN]	Holding force [kN]	Blow out	Weight [Kg]
424069	K10	10	25	-	1,35
424085	K10	10	25	√	1,35
423947	K20	20	55	-	3,75
423962	K20	20	55	√	3,75
424127	K40	40	105	-	4,97
424143	K40	40	105	√	4,97

#### Application:

Zero-point clamping system for set-up-time-optimized clamping with cutting and non-cutting processing in all areas, also in the food, pharmaceutical and chemical industry.

#### Note:

The flange version permits a simplified installation in the body. This is exactly positioned via the centring function. The clamping module can be operated from the outside via a tube connection or from the bottom via an O-ring connection.

This is opened hydraulically (1) and mechanically locked through spring force. Subsequent uncoupling of the pressure lines is possible at all times (module is tensioned pressure-free).

The clamping module has one connection: 1x hyd. opening (1).

The clamping module with blow-out has two connections:

1x hyd. opening (1) / 1x pneum. blow-out (3).

#### Dimensions

Order no.	Size	dia. DA	dia. DN	dia. D1	HA	K	dia. LK	M	R	T
424069	K10	100	22	67	24	9	90	M5	G1/8	5,9
424085	K10	100	22	67	24	9	90	M5	G1/8	5,9
423947	K20	136	32	100	35	13	124	M6	G1/8	8,9
423962	K20	136	32	100	35	13	124	M6	G1/8	8,9
424127	K40	180	40	125	45	15	163	M8	G1/4	11,9
424143	K40	180	40	125	45	15	163	M8	G1/4	11,9

## No. 6151L

### Installation clamping module, round, flange version

Pneumatic opening.  
Opening operating pressure: min. 8 bar - max. 12 bar  
Retensioning operating pressure (turbo): min. 5 bar - max. 6 bar  
Cover and piston hardened.  
Repeatability < 0.005 mm.

**NEW!**



STAINLESS STEEL

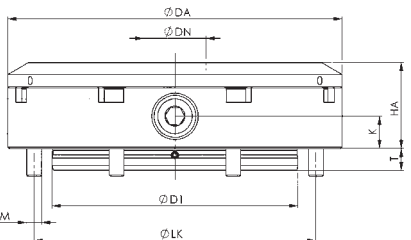
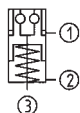

Order no.	Size	Pull-in/locking force up to [kN]	Holding force [kN]	Weight [Kg]
424101	K10	8	25	1,35
423988	K20	17	55	3,75
424168	K40	30	105	4,97

#### Application:

Zero-point clamping system for set-up-time-optimized clamping with cutting and non-cutting processing in all areas, also in the food, pharmaceutical and chemical industry.

#### Note:

The flange version permits a simplified installation in the body. This is exactly positioned via the centring function. This is opened pneumatically (1) and mechanically locked through spring force. To achieve the specified pull-in and locking forces, this must be briefly retensioned pneumatically (turbo) (2). Subsequent uncoupling of the pressure lines is possible at all times (module is tensioned pressure-free).

Use of the pneumatic pressure booster (cat. p. 57) is recommended.

The clamping module has two connections:

1x pneum. opening (1) / 1x pneum. retensioning (turbo) (2).

#### Dimensions

Order no.	Size	dia. DA	dia. DN	dia. D1	HA	K	dia. LK	M	R	T
424101	K10	100	22	67	24	9	90	M5	G1/8	5,9
423988	K20	136	32	100	35	13	124	M6	G1/8	8,9
424168	K40	180	40	125	45	15	163	M8	G1/4	11,9

Subject to technical alterations.

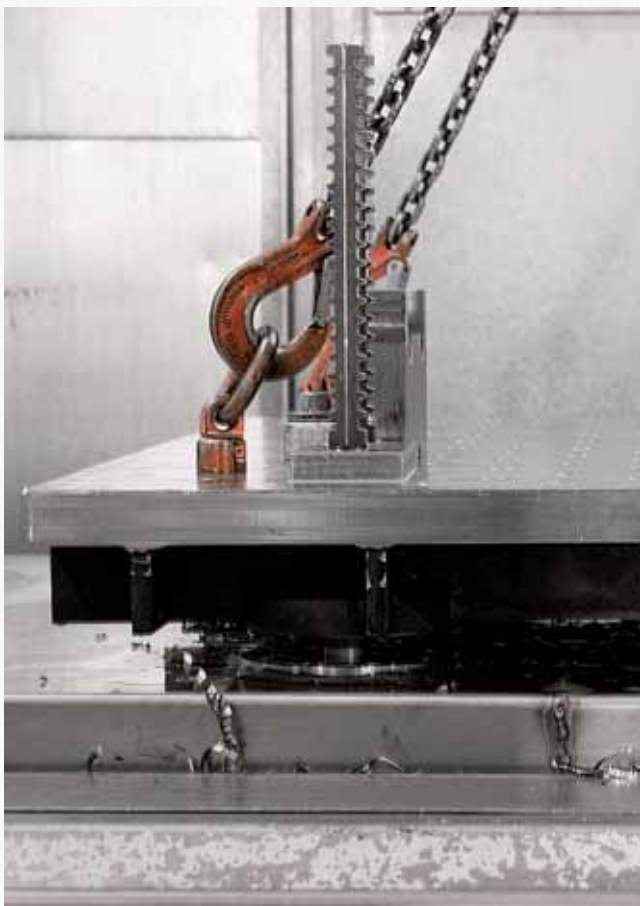

Subject to technical alterations.

## SURFACE-MOUNTED CLAMPING MODULES

The AMF surface-mounted clamping modules are installed on pallets, machine tables, clamping brackets and cubes. Usable when cutting, grinding, eroding and on plastic-processing machines as well as for fixture construction with mounting fixtures and handling systems.

The AMF clamping modules can be installed in all positions. Whether vertical or overhead - mounting works completely without assembly tools.

Surface-mounted clamping modules are available in four different sizes:

- > **Clamping modules K40** - dia. 148 mm -  
Pull-in/locking force up to 40 kN - Holding force 105 kN
- > **Clamping modules K20** - dia. 112 mm -  
Pull-in/locking force up to 20 kN - Holding force 55 kN
- > **Clamping modules K10** - dia. 78 mm -  
Pull-in/locking force up to 10 kN - Holding force 25 kN
- > **Clamping modules K5** - dia. 45 mm -  
Pull-in/locking force up to 5 kN - Holding force 13 kN

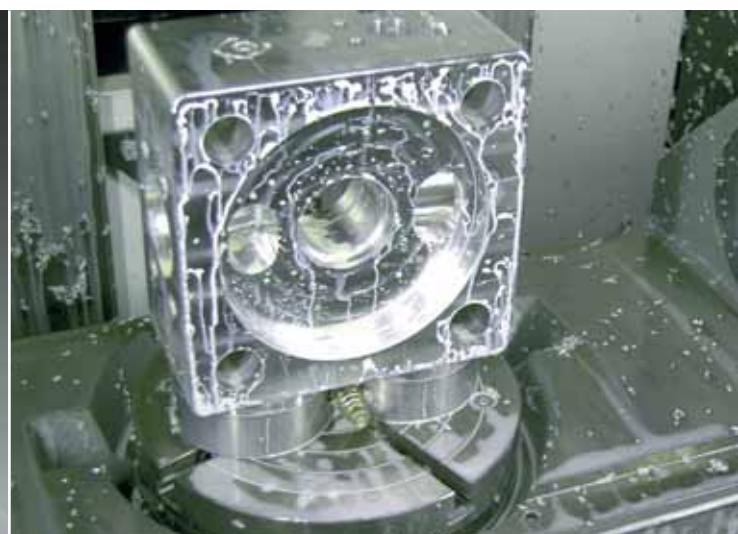

The clamping nipple is screwed directly into the workpiece

## No. 6370AARH

### Surface-mounted clamping module, round

Hydraulic opening.  
Opening operating pressure: min. 50 bar - max. 60 bar  
Cover and piston hardened.  
Repeatability < 0.005 mm.



STAINLESS STEEL

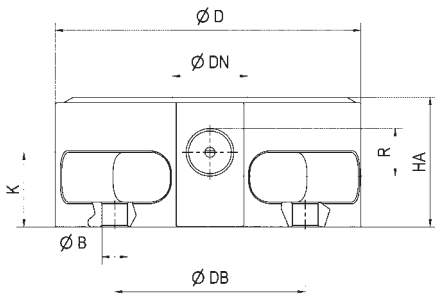

Order no.	Size	Pull-in/locking force up to [kN]	Holding force [kN]	Weight [g]
306159	K 5	5	13	300

#### Application:

Zero-point clamping system for set-up-time-optimized clamping with cutting and non-cutting processing in all areas, also in the food, pharmaceutical and chemical industry.

#### Note:

The surface-mounted clamping module has high holding, pull-in and locking forces. This is opened hydraulically (1) and mechanically locked through spring force. Subsequent uncoupling of the pressure lines is possible at all times (module is tensioned pressure-free). The clamping module has one connection: 1x hyd. opening (1).

#### On request:

- Individual housing

#### Dimensions

Order no.	Size	dia. B	dia. D	dia. DB	dia. DN	HA	K	R
306159	K 5	5,8	62	54	15	26	15	G1/8

## No. 6370AARL

### Surface-mounted clamping module, round

Pneumatic opening.  
Opening operating pressure: min. 8 bar - max. 12 bar  
Retensioning operating pressure (turbo): min. 5 bar - max. 6 bar  
Cover and piston hardened.  
Repeatability < 0.005 mm.



STAINLESS STEEL

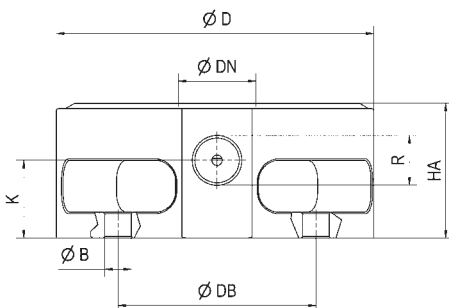

Order no.	Size	Pull-in/locking force up to [kN]	Holding force [kN]	Weight [g]
306175	K 5	1,5	13	300

#### Application:

Zero-point clamping system for set-up-time-optimized clamping with cutting and non-cutting processing in all areas, also in the food, pharmaceutical and chemical industry.

#### Note:

The surface-mounted clamping module has high holding, pull-in and locking forces. This is opened pneumatically (1) and mechanically locked through spring force. To achieve the specified pull-in and locking forces, it must be briefly retensioned pneumatically (turbo) (2). Subsequent uncoupling of the pressure lines is possible at all times (module is tensioned pressure-free).

Use of the pneumatic pressure booster (cat. p. 57) is recommended. The clamping module has two connections: 1x pneum. opening (1) / 1x pneum. retensioning (turbo) (2).

#### On request:

- Individual housing

#### Dimensions

Order no.	Size	dia. B	dia. D	dia. DB	dia. DN	HA	K	R
306175	K 5	5,8	62	54	15	26	15	G1/8

## No. 6370AARH

### Surface-mounted clamping module, round

Hydraulic opening.  
Opening operating pressure: min. 50 bar - max. 60 bar  
Cover and piston hardened.  
Repeatability < 0.005 mm.



STAINLESS STEEL

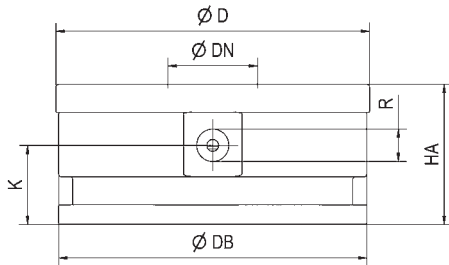
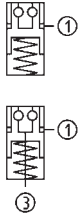

Order no.	Size	Pull-in/locking force up to [kN]	Holding force [kN]	Blow out	Weight [Kg]
303487	K10	10	25	-	0,90
303545	K10	10	25	√	0,90
302828	K20	20	55	-	2,75
302836	K20	20	55	√	2,70
302869	K40	40	105	-	3,85
302877	K40	40	105	√	3,80

#### Application:

Zero-point clamping system in combination with clamping flanges (cat. p. 25) for set-up-time-optimized clamping with cutting and non-cutting processing in all areas, also in the food, pharmaceutical and chemical industry.

#### Note:

The surface-mounted clamping module has high holding, pull-in and locking forces. This is opened hydraulically (1) and mechanically locked through spring force. Subsequent uncoupling of the pressure lines is possible at all times (module is tensioned pressure-free). The clamping module has one connection: 1x hyd. opening (1). Clamping module with blow-out has two connections: 1x hyd. opening (1) / 1x pneum. blow-out (3).

#### On request:

- Automation solutions

#### Dimensions

Order no.	Size	dia. D	dia. DB	dia. DN	HA	K	R
303487	K10	78	77,5	22	30	16,50	G1/8
303545	K10	78	77,5	22	30	16,50	G1/8
302828	K20	112	110,0	32	50	28,25	G1/4
302836	K20	112	110,0	32	50	28,25	G1/4
302869	K40	148	146,0	40	62	32,50	G1/4
302877	K40	148	146,0	40	62	32,50	G1/4

## No. 6370AARL

### Surface-mounted clamping module, round

Pneumatic opening.  
Opening operating pressure: min. 8 bar - max. 12 bar  
Retensioning operating pressure (turbo): min. 5 bar - max. 6 bar  
Cover and piston hardened.  
Repeatability < 0.005 mm.



STAINLESS STEEL

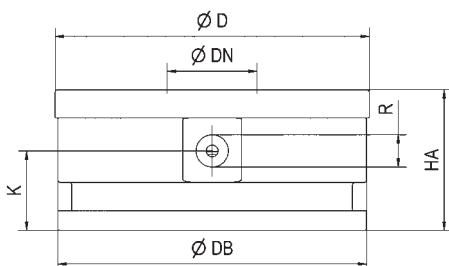
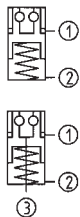

Order no.	Size	Pull-in/locking force up to [kN]	Holding force [kN]	Blow out	Weight [Kg]
303529	K10	8	25	-	0,90
305193	K10	8	25	√	0,90
302844	K20	17	55	-	2,60
302851	K20	17	55	√	2,60
302885	K40	30	105	-	6,45
302893	K40	30	105	√	6,40

#### Application:

Zero-point clamping system in combination with clamping flanges (cat. p. 25) for set-up-time-optimized clamping with cutting and non-cutting processing in all areas, also in the food, pharmaceutical and chemical industry.

#### Note:

The surface-mounted clamping module has high holding, pull-in and locking forces. This is opened pneumatically (1) and mechanically locked through spring force. To achieve the specified pull-in and locking forces, it must be briefly retensioned pneumatically (turbo) (2). Subsequent uncoupling of the pressure lines is possible at all times (module is tensioned pressure-free). Use of the pneumatic pressure booster (cat. p. 57) is recommended. The clamping module has two connections: 1x pneum. opening (1)/1x pneum. retensioning (turbo) (2). Clamping module with blow-out has three connections: 1x pneum. opening (1) / 1x pneum. retensioning (turbo) (2), 1x pneum. blow-out (3).

#### On request:

- Automation solutions

#### Dimensions

Order no.	Size	dia. D	dia. DB	dia. DN	HA	K	R
303529	K10	78	77,5	22	30	16,50	G1/8
305193	K10	78	77,5	22	30	16,50	G1/8
302844	K20	112	110,0	32	50	28,25	G1/4
302851	K20	112	110,0	32	50	28,25	G1/4
302885	K40	148	146,0	40	62	32,50	G1/4
302893	K40	148	146,0	40	62	32,50	G1/4

## No. 6370AAQH

### Surface-mounted clamping module, square

Hydraulic opening.  
Opening operating pressure: min. 50 bar - max. 60 bar  
Cover and piston hardened.  
Repeatability < 0.005 mm.



STAINLESS STEEL

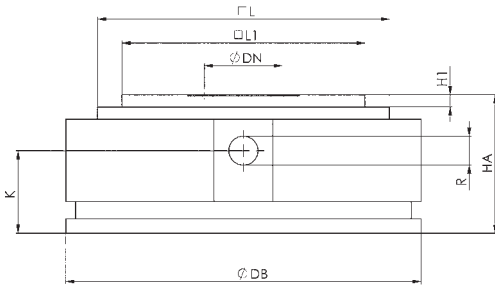
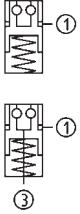

Order no.	Size	Pull-in/locking force up to [kN]	Holding force [kN]	Blow out	Weight [Kg]
305664	K10	10	25	-	1,00
305722	K10	10	25	✓	1,00
305680	K20	20	55	-	2,90
305748	K20	20	55	✓	2,85
305706	K40	40	105	-	4,00
305763	K40	40	105	✓	3,95

#### Application:

Zero-point clamping system in combination with clamping flanges (cat. p. 25) for set-up-time-optimized clamping with cutting and non-cutting processing in all areas, also in the food, pharmaceutical and chemical industry.  
A square clamping module prevents the pallet from twisting. The indexing function enables exact positioning every 90°.

#### Note:

The surface-mounted clamping module has high holding, pull-in and locking forces. This is opened hydraulically (1) and mechanically locked through spring force. Subsequent uncoupling of the pressure lines is possible at all times (module is tensioned pressure-free).  
The clamping module has one connection: 1x hyd. opening (1).  
Clamping module with blow-out has two connections: 1x hyd. opening (1) / 1x pneum. blow-out (3).

#### On request:

- Automation solutions

#### Dimensions

Order no.	Size	dia. DB	dia. DN	HA	H1	K	L	L1	R
305664	K10	77,5	22	30	3,5	16,5	85	70	G1/8
305722	K10	77,5	22	30	3,5	16,5	85	70	G1/8
305680	K20	146,0	32	57	5,0	35,5	120	100	G1/4
305748	K20	146,0	32	57	5,0	35,5	120	100	G1/4
305706	K40	240,0	40	62	5,0	32,5	150	130	G1/4
305763	K40	240,0	40	62	5,0	32,5	150	130	G1/4

## No. 6370AAQL

### Surface-mounted clamping module, square

Pneumatic opening.  
Opening operating pressure: min. 8 bar - max. 12 bar  
Retensioning operating pressure (turbo): min. 5 bar - max. 6 bar  
Cover and piston hardened.  
Repeatability < 0.005 mm.



STAINLESS STEEL

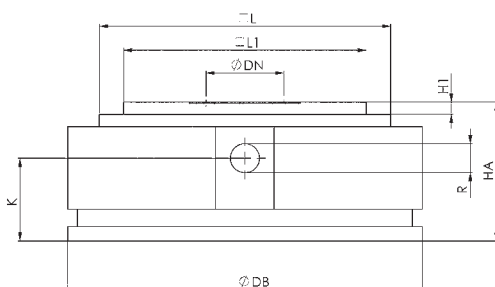
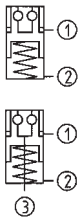

Order no.	Size	Pull-in/locking force up to [kN]	Holding force [kN]	Blow out	Weight [Kg]
305672	K10	8	25	-	1,00
305730	K10	8	25	✓	1,00
305698	K20	17	55	-	2,75
305755	K20	17	55	✓	2,70
305714	K40	30	105	-	6,60
305771	K40	30	105	✓	6,50

#### Application:

Zero-point clamping system in combination with clamping flanges (cat. p. 25) for set-up-time-optimized clamping with cutting and non-cutting processing in all areas, also in the food, pharmaceutical and chemical industry.  
A square clamping module prevents the pallet from twisting. The indexing function enables exact positioning every 90°.

#### Note:

The surface-mounted clamping module has high holding, pull-in and locking forces. This is opened pneumatically (1) and mechanically locked through spring force. To achieve the specified pull-in and locking forces, it must be briefly retensioned pneumatically (turbo) (2). Subsequent uncoupling of the pressure lines is possible at all times (module is tensioned pressure-free).  
Use of the pneumatic pressure booster (cat. p. 57) is recommended.  
The clamping module has two connections: 1x pneum. opening (1) / 1x pneum. retensioning (turbo) (2). Clamping module with blow-out has three connections: 1x pneum. opening (1) / 1x pneum. retensioning (turbo) (2), 1x pneum. blow-out (3).

#### On request:

- Automation solutions

#### Dimensions

Order no.	Size	dia. DB	dia. DN	HA	H1	K	L	L1	R
305672	K10	77,5	22	30	3,5	16,5	85	70	G1/8
305730	K10	77,5	22	30	3,5	16,5	85	70	G1/8
305698	K20	146,0	32	57	5,0	35,5	120	100	G1/4
305755	K20	146,0	32	57	5,0	35,5	120	100	G1/4
305714	K40	240,0	40	62	5,0	32,5	150	130	G1/4
305771	K40	240,0	40	62	5,0	32,5	150	130	G1/4

Subject to technical alterations.



## No. 6370ZB

### Clamping flange, Set

consisting of two single-clamp brackets.  
Nitrided and burnished.



Order no.	Size	Set contents [pce]	dia. D	dia. DB	H	dia. LK	M	Weight [g]
426825	K10	2	114	77,5	7,75	94	8,5	360
426833	K20	2	164	110,0	13,00	136	11,0	800
426841	K40	2	202	146,0	16,00	172	13,0	1100

### Application:

Clamping flanges are used to fasten surface-mounted clamping modules on the machine table.

### On request:

- Special clamping flanges for various T-slot tables
- Clamping flange and housing manufactured as a single piece

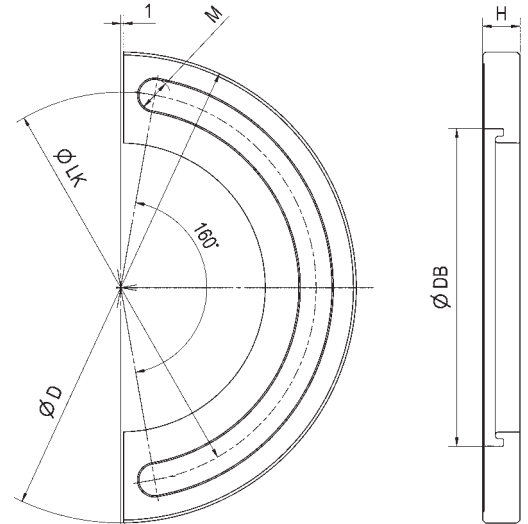

### Examples of machine-table mounting:

**K10** - Groove distance 50 mm

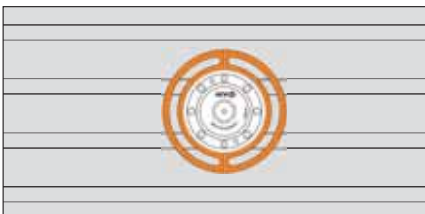

Groove distance 63 mm

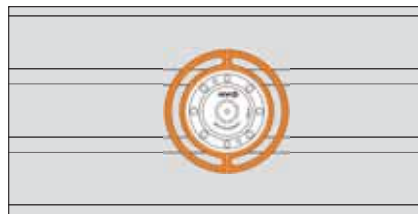

Groove distance 80 mm

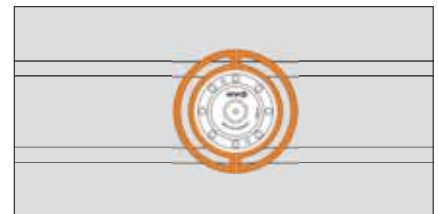

**K20** - Groove distance 50 mm

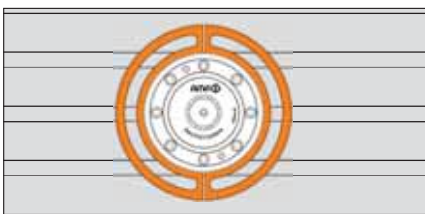

Groove distance 63 mm

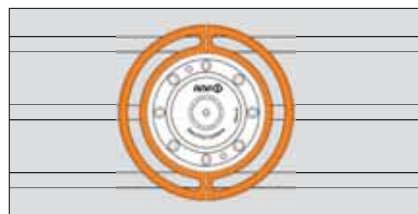

Groove distance 80 mm

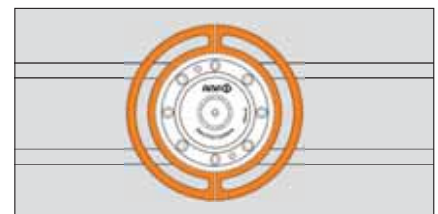

**K40** - Groove distance 50 mm

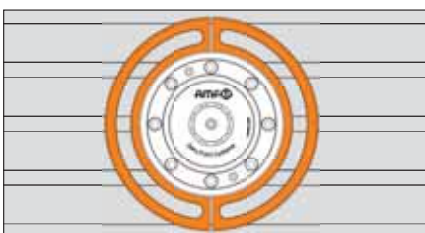

Groove distance 63 mm

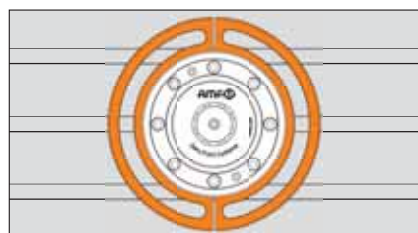

Groove distance 80 mm

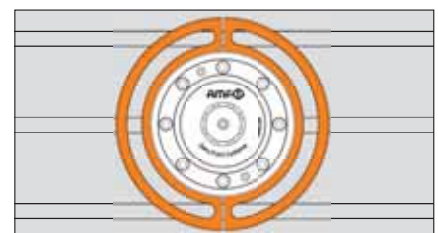

## No. 6370HARH

### Horizontal rapid-clamping cylinder

Hydraulic opening.  
Opening operating pressure: min. 50 bar - max. 60 bar  
Cover and piston hardened.  
Repeatability < 0.005 mm.



STAINLESS STEEL

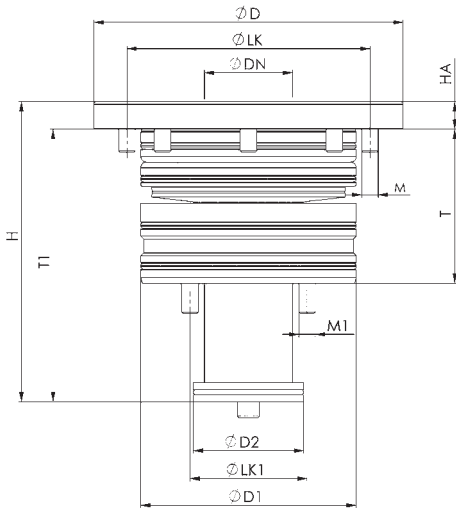

Order no.	Size	Pull-in/locking force up to [kN]	Holding force [kN]	Blow out	Advance / retract hyd. piston	Weight [Kg]
303065	K20	20	55	-	-	2,1
306217	K20	20	55	-	√	2,1
303073	K20	20	55	√	-	2,1
306233	K20	20	55	√	√	2,1
303107	K40	40	105	-	-	5,2
306258	K40	40	105	-	√	5,2
303115	K40	40	105	√	-	5,2
306274	K40	40	105	√	√	5,2

### Application:

Zero-point clamping system for set-up-time-optimized clamping with cutting and non-cutting processing in all areas, also in the food, pharmaceutical and chemical industry. For installation in clamping brackets, cubes and towers. The horizontal rapid-clamping cylinder is used to change fixtures quickly and easily by means of the suspension piston with manual power, hydraulic or handling device.

### Note:

The horizontal rapid-clamping cylinder has high holding, pull-in and locking forces. This is opened hydraulically (1) and mechanically locked through spring force. Subsequent uncoupling of the pressure lines is possible at all times (module is tensioned pressure-free).

### Design:

As standard, there is a manual (hand power) or hydraulic run-out and run-in movements of the suspension piston.

- Cylinder has one connection: 1x hyd. opening (1),
- Cylinder with hydraulic advance motion has three connections: 1x hyd. opening (1), Run out 1x hyd. piston opening (5), run in 1x hyd. piston opening (4).
- Cylinder with blow-out has two connections: 1x hyd. opening (1) / 1x pneum. blow-out (3),
- Cylinder with blow-out and hydraulic run-out movement has four connections: 1x hyd. opening (1), Run out 1x hyd. suspension piston opening (5), run in 1x hyd. suspension piston opening (4), 1x pneum. blow-out (3).

### On request:

- Installation diagrams

### Dimensions

Order no.	Size	dia. D	dia. DN	dia. D1	dia. D2	H	HA	dia. LK	dia. LK1	M	M1	T	T1
303065	K20	112	32	78	40	109	10	88	60	M6	M6	56,5	99
306217	K20	112	32	78	40	109	10	88	60	M6	M6	56,5	99
303073	K20	112	32	78	40	109	10	88	60	M6	M6	56,5	99
306233	K20	112	32	78	40	109	10	88	60	M6	M6	56,5	99
303107	K40	148	40	102	48	144	15	118	76	M8	M8	73,0	129
306258	K40	148	40	102	48	144	15	118	76	M8	M8	73,0	129
303115	K40	148	40	102	48	144	15	118	76	M8	M8	73,0	129
306274	K40	148	40	102	48	144	15	118	76	M8	M8	73,0	129

... extended condition

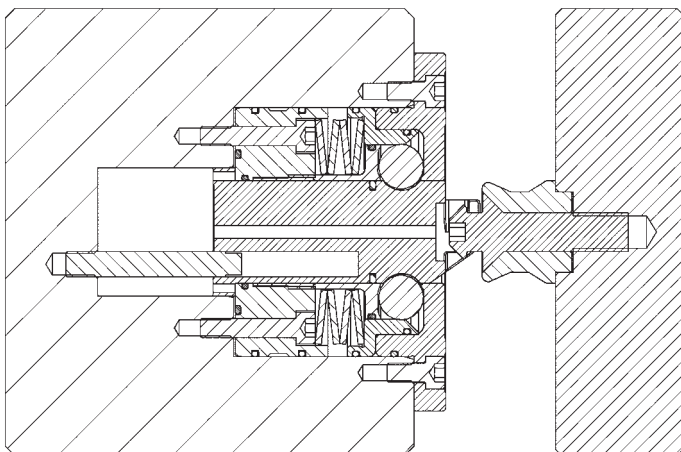

... retracted and locked condition

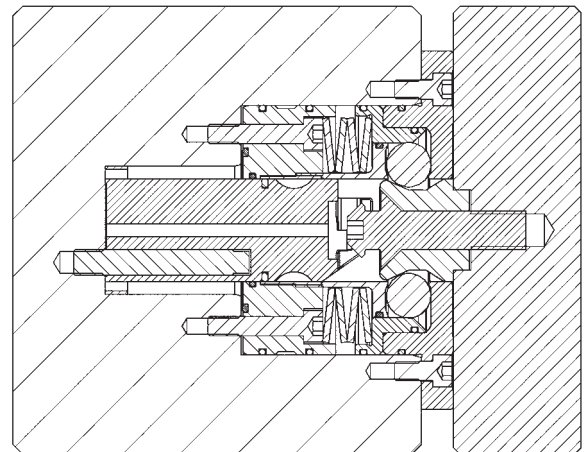

Subject to technical alterations.

## HORIZONTAL RAPID-CLAMPING CYLINDER

This is how to make vertical palletization quick and uncomplicated:

- > No searching for the holes
- > No hydraulic or pneumatic pre-tensioning
- > No damage from zero-point hole and nipple
- > No risk of injury
- > Reduced set-up times and thus cost savings

Flexibly usable in clamping towers, clamping brackets, automated handling devices or in general machine building.

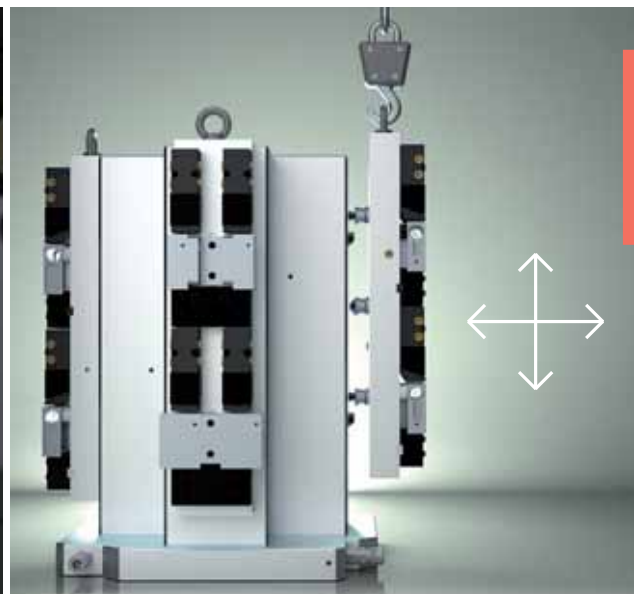

> Whether by hand, with crane, handling device or robot: Horizontal rapid-clamping cylinders offer maximum protection and comfort.

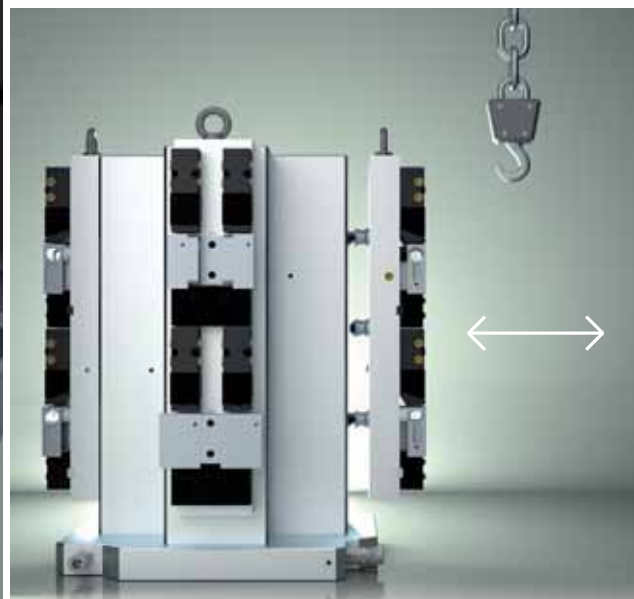

> After the pallet has been mounted, it can easily be pushed in and out. This process can be automated, if desired.



The AMF zero-point clamping technology makes time-consuming alignment of the workpieces on deep-hole drills superfluous.

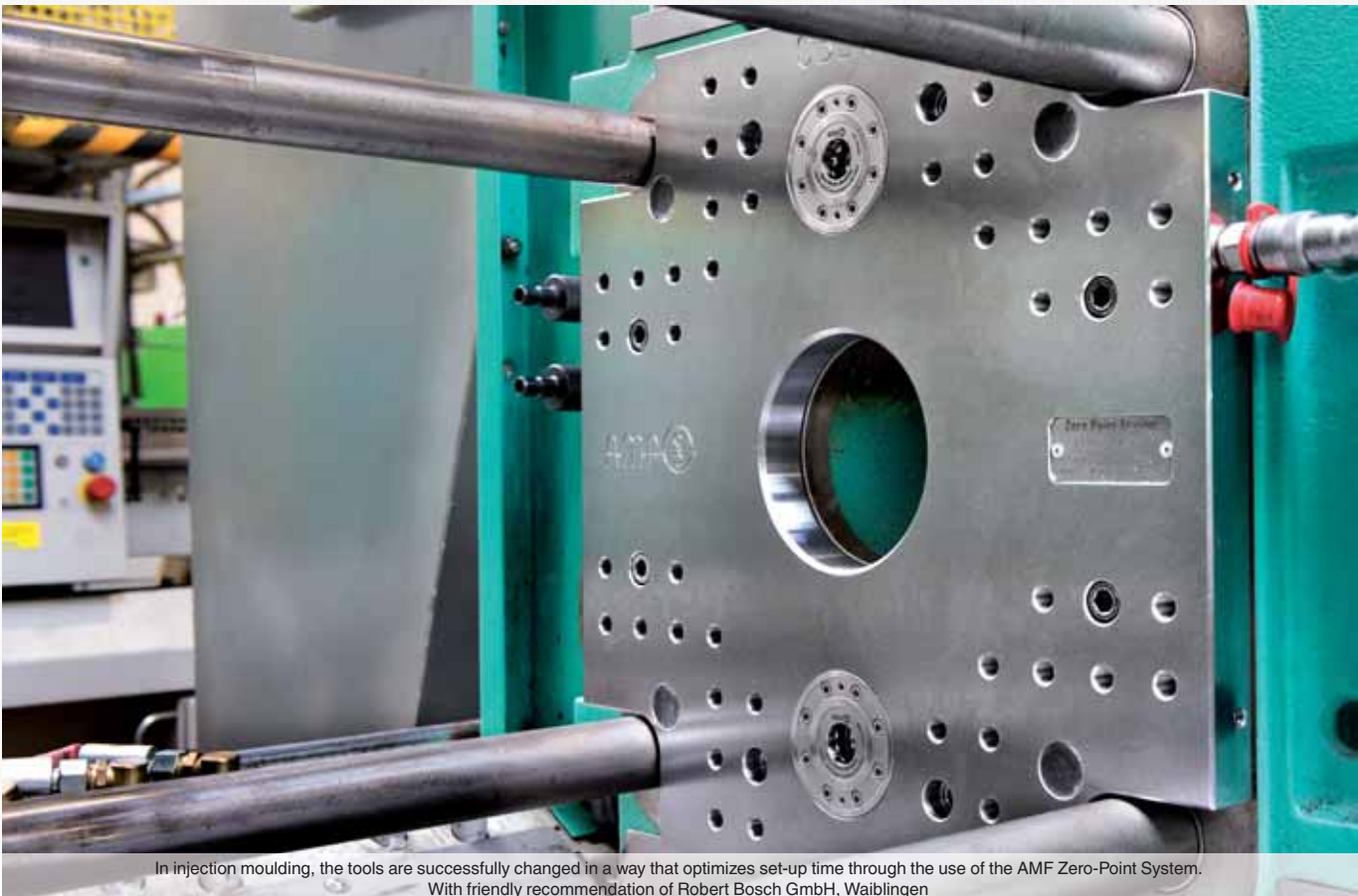

In injection moulding, the tools are successfully changed in a way that optimizes set-up time through the use of the AMF Zero-Point System.  
With friendly recommendation of Robert Bosch GmbH, Waiblingen

Subject to technical alterations.

## No. 6370KARH

### Compact cylinder

Hydraulic opening.  
 Opening operating pressure: min. 50 bar - max. 60 bar  
 Cover and piston hardened.  
 Repeatability < 0.005 mm.



STAINLESS STEEL

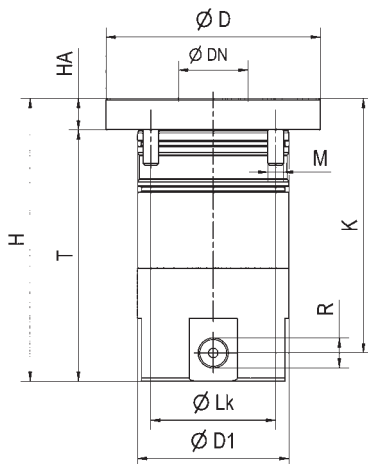

Order no.	Size	Pull-in/locking force up to [kN]	Holding force [kN]	Weight [Kg]
303503	K10	1,3	25	2,5

### Application:

For retrofitting to modular profiles, columns, tombstones and cubes. Can be used with thin wall sections.

### Note:

There are 5 standard connection options. 4 connections are installed laterally on the outside surface at a 90° angle. Connection is also possible in the base of the compact cylinder.

### On request:

- Installation diagrams
- Automation solutions

### Dimensions

Order no.	Size	dia. D	dia. DN	dia. D1	H	HA	K	dia. LK	M	R	T
303503	K10	68	22	48	90	10	81	4/56	M6	G1/8	80



Subject to technical alterations.



The Zero-Point System used together with the AMF magnetic clamping technology  
With friendly recommendation of Bäuml CNC-Fertigungs-GmbH & Co. KG, Weiden



With friendly recommendation of Bäuml CNC-Fertigungs-GmbH & Co. KG, Weiden

Subject to technical alterations.



With friendly recommendation of Bäuml CNC-Fertigungs-GmbH & Co. KG, Weiden



The high precision of the AMF Zero-Point System permits use in grinding



Use in the food industry

# AUTOMATION SOLUTIONS FROM AMF

The enormous capability and flexibility of use of modern processing machines is undisputed. To be able to use these capabilities in reality requires more than just fast machines. An automation solution consists today of a number of multiply linked, versatile products and technologies.

Through the possibility of a fully automatic and process-sure machine configuration, our automation solutions meet the requirements for seamless integration into the automation system. Numerous sensing options, optional media ducts and blow-out and blow-off of the modules speak for themselves!

**Persuade yourself of the automation potential of the AMF zero-point clamping modules!**

## 1 > BLOW-OFF



## 2 > SUPPORT CONTROL



### \_1 Chips and dirt on the support surface?

No problem! The blow-off functions using compressed air cleans the support surfaces from all dirt and chips.

### \_2 Is a workpiece lying without gap or not?

Placing a workpiece or fixture on the clamping module creates a pneumatic static pressure, which is sensed by a differential pressure sensor.

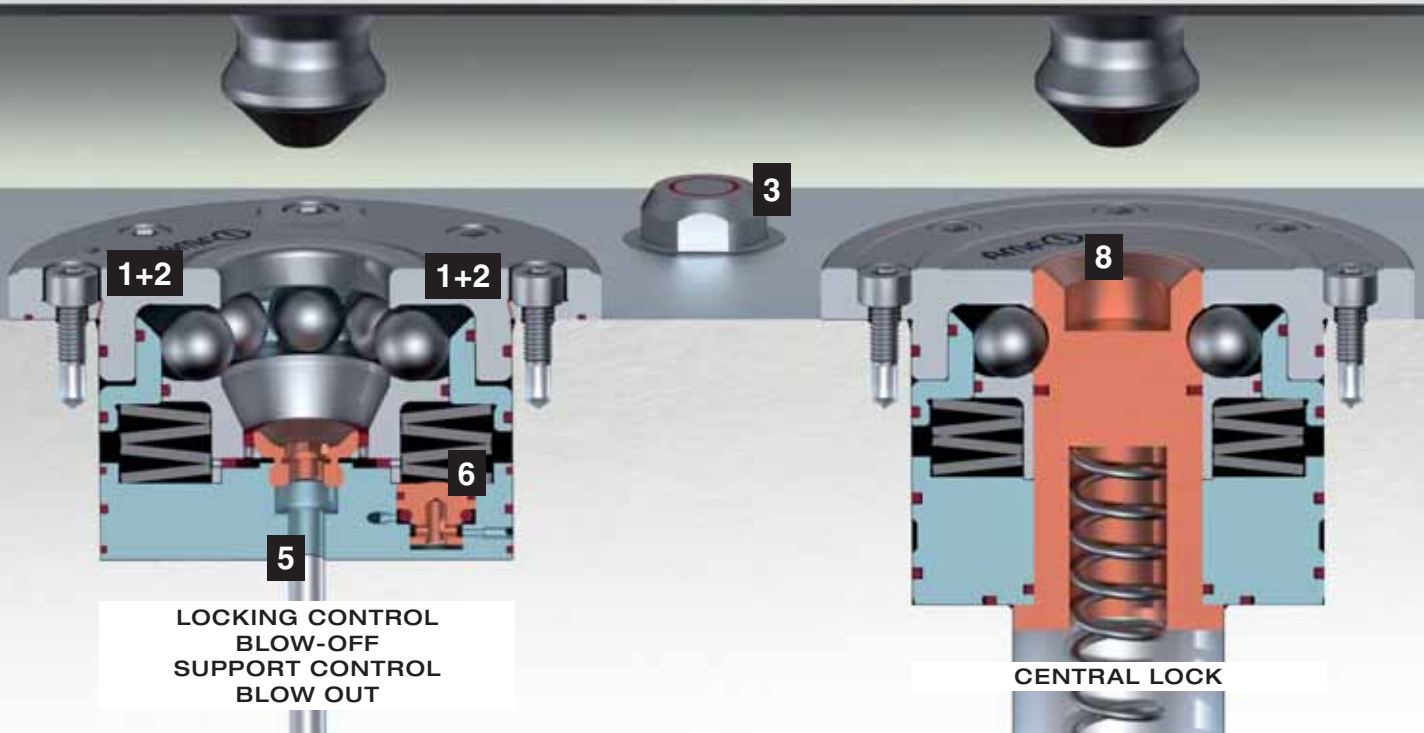



3 > MEDIA DUCTS



5 > INTERNAL BLOW-OUT



7 > ELECTRICAL SENSING

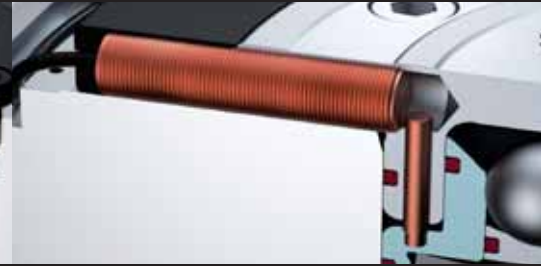

4 > NIPPLE SENSING



6 > LOCKING CONTROL

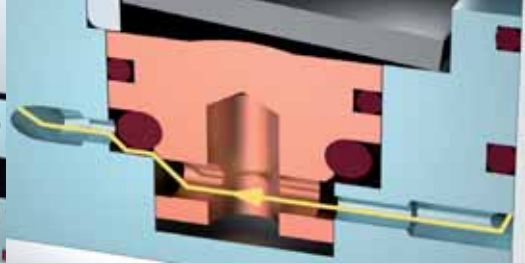

8 > CENTRAL LOCK



**\_3 Are media ducts to a fixture necessary?**

Oil, compressed air, water, etc. can be run through our couplings without leaks.

**\_5 Dirt and chips in the clamping module?**

Blowing out with compressed air cleans the inside from all dirt and chips.

**\_7 Is the module open or closed?**

The integrated inductive sensor can sense the piston position (open/closed) of the clamping module.

**\_4 Is the clamping nipple present on the fixture?**

The retracting nipple actuates a stop valve, which eliminates the pneumatic or hydraulic static pressure. This condition is sensed via a differential pressure switch.

**\_6 Is the module locked?**

With an open module, the integrated stop valve creates a pneumatic or hydraulic static pressure, which is sensed via a differential pressure switch.

**\_8 Dirt and chips unwelcome in the module?**

The lagging central lock prevents penetration of dirt and chips when the clamping nipple is being run out. The central lock replaces the previously required protection nipple.

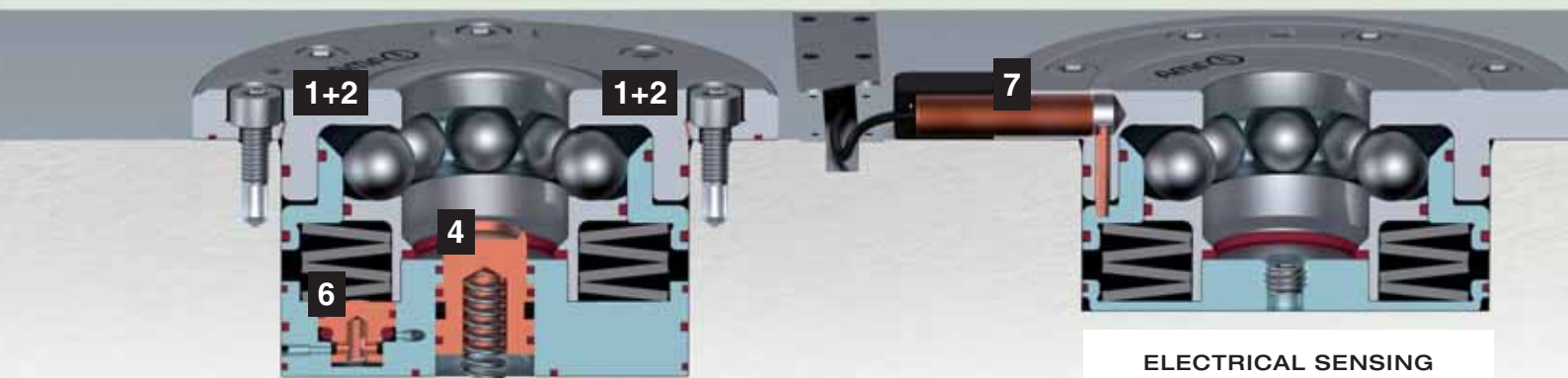

**NIPPLE SENSING  
LOCKING CONTROL  
BLOW-OFF  
SUPPORT CONTROL**

**ELECTRICAL SENSING**

## No. 6100H-20-06

### Installation clamping module for automation solutions

Hydraulic opening.  
Opening operating pressure: min. 50 bar - max. 60 bar  
Cover and piston hardened.  
Repeatability < 0.005 mm.

With locking control (hydraulic or pneumatic), support control (pneumatic) and nipple sensing.

**NEW!**



STAINLESS STEEL

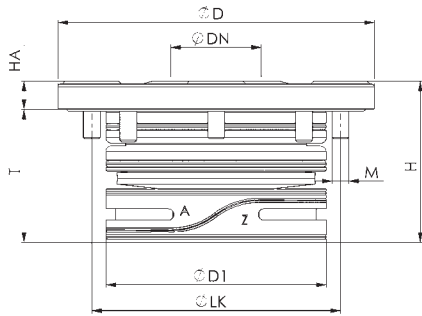
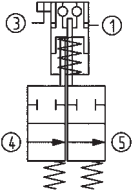

Order no.	Size	Pull-in/locking force up to [kN]	Holding force [kN]	Weight [Kg]
427161	K20	20	55	2,8

#### Application:

Zero-point clamping system for automation solutions for set-up-time-optimized clamping with cutting and non-cutting processing in all areas, also in the food, pharmaceutical and chemical industry.

#### Design:

Central blow-out, support surfaces as island design with integrated blow-out, locking control and nipple sensing.

#### Note:

Locking control: Static pressure with opened clamping module, flow-through only with locked clamping module and presence of clamping nipple.

Support control: Static pressure with supported change pallet.

This is opened hydraulically (1) and mechanically locked through spring force. Subsequent uncoupling of the pressure lines is possible at all times (module is tensioned pressure-free).

Module has four connections:

1x hyd. opening (1) / 1x pneum. support control (3) /

1x hyd. or pneum. locking control and nipple sensing input (4) /

1x hyd. or pneum. locking control and nipple sensing output (5).

#### On request:

- Installation diagrams
- Additional automation options

#### Dimensions

Order no.	Size	dia. D	dia. DN	dia. D1	dia. LK	H	HA	M	T
427161	K20	112	32	78	88	57	10	M 6	47

## No. 6100H-20-05

### Installation clamping module for automation solutions

Hydraulic opening.  
Opening operating pressure: min. 50 bar - max. 60 bar  
Cover and piston hardened.  
Repeatability < 0.005 mm.

With locking control (hydraulic or pneumatic) and support control (pneumatic).



STAINLESS STEEL

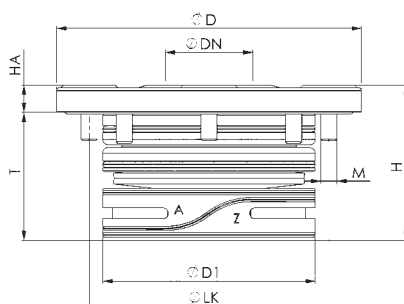
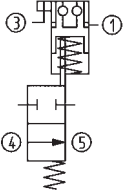

Order no.	Size	Pull-in/locking force up to [kN]	Holding force [kN]	Weight [Kg]
427146	K20	20	55	2,8

#### Application:

Zero-point clamping system for automation solutions for set-up-time-optimized clamping with cutting and non-cutting processing in all areas, also in the food, pharmaceutical and chemical industry.

#### Design:

Central blow-out, support surfaces as island design with integrated blow-out and locking control.

#### Note:

Locking control: Static pressure with opened clamping module, flow-through only with locked clamping module.

Support control: Static pressure with supported change pallet.

This is opened hydraulically (1) and mechanically locked through spring force. Subsequent uncoupling of the pressure lines is possible at all times (module is tensioned pressure-free).

The module has four connections:

1x hyd. opening (1) / 1x pneum. support control (3) /

1x hyd. or pneum. locking control input (4) /

1x hyd. or pneum. locking control output (5).

#### On request:

- Installation diagrams
- Additional automation options

#### Dimensions

Order no.	Size	dia. D	dia. DN	dia. D1	dia. LK	H	HA	M	T
427146	K20	112	32	78	88	57	10	M 6	47

Subject to technical alterations.

## No. 6370EARHMV

### Installation clamping module with central locking

Hydraulic opening.  
 Opening operating pressure: min. 50 bar - max. 60 bar  
 Cover and piston hardened.  
 Repeatability < 0.005 mm.



STAINLESS STEEL

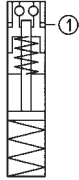

Order no.	Size	Pull-in/locking force up to [kN]	Holding force [kN]	Weight [Kg]
306027	K20	20	55	2,1

#### Application:

Zero-point clamping system for automation solutions for set-up-time-optimized clamping with cutting and non-cutting processing in all areas, also in the food, pharmaceutical and chemical industry.

#### Note:

The central locking element prevents the entry of dirt into the nipple bore. The central locking element advances with spring force.

#### On request:

- Installation diagrams
- Hydraulic advance of the central locking element

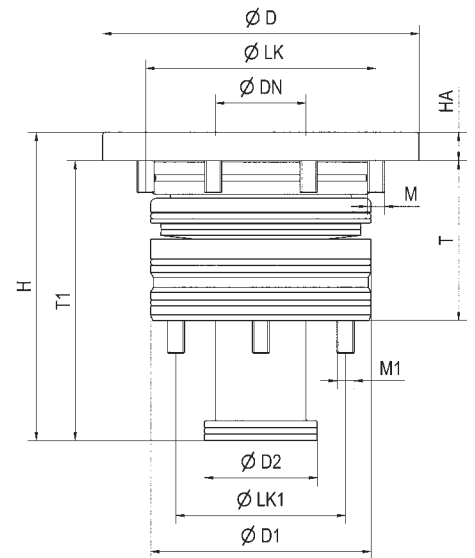

#### Dimensions

Order no.	Size	dia. D	dia. DN	dia. D1	dia. D2	H	HA	dia. LK	dia. LK1	M	M1	T	T1
306027	K20	112	32	78	40	109	10	88	60	M 6	M 6	66,5	99

## No. 6101L

### Installation clamping module with sensor monitor, mounting flange

Pneumatic opening.  
 Opening operating pressure: min. 8 bar - max. 12 bar  
 Retensioning operating pressure (turbo): min. 5 bar - max. 6 bar  
 Cover and piston hardened.  
 Repeatability < 0.005 mm.

**NEW!**



STAINLESS STEEL

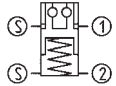

Order no.	Size	Pull-in/locking force up to [kN]	Holding force [kN]	Weight [Kg]
424580	K10	8,5	25	2,4
424192	K20	17,0	55	6,9
424564	K40	30,0	105	11,0

#### Application:

Zero-point clamping system for automation solutions for set-up-time-optimized clamping with cutting and non-cutting processing in all areas, also in the food, pharmaceutical and chemical industry.

#### Note:

The installation clamping module with sensor monitor contains 2 inductive sensors (connection type: S8 plug, cable length: 150 mm) for condition control (open / locked). This is pneumatically opened (1) and mechanically locked through spring force. To achieve the specified pull-in and locking forces, it must be briefly retensioned pneumatically (turbo) (2). Subsequent uncoupling of the pressure lines is possible at all times (module is tensioned pressure-free). Use of the pneumatic pressure intensifier (cat. page 57) is recommended. Clamping module has two connections: 1x pneum. opening (1) / 1x pneum. retensioning (turbo) (2).

#### On request:

- Installation diagrams
- Additional automation options

#### Dimensions

Order no.	Size	dia. DA	dia. D	dia. DN	H	HA	K	dia. M	dia. N H7	R
424580	K10	104	78	22	37	44	12	6,6	8	G1/8
424192	K20	143	112	32	38	48	26	9,0	8	G1/8
424564	K40	180	148	40	47	62	32	11,0	10	G1/4

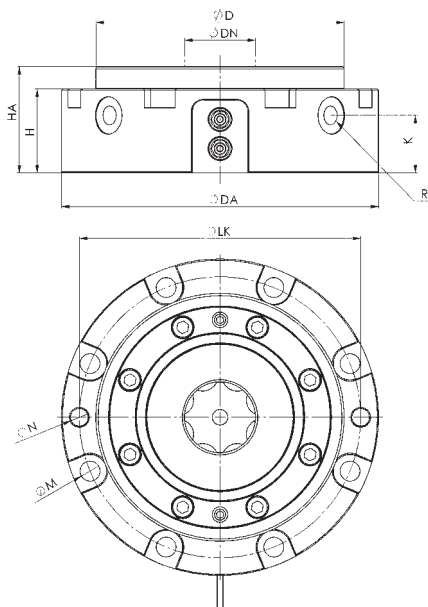



Automation solution (order no. 427161) with lock and support control as well as nipple sensing in use in a fully automated production process with robot loading.



„Turbine“ high-end clamping module (order no. 420919) in use in a fully automated production process with robot loading.

## No. 6102H

### “Turbine“ high-end clamping module for full automation

Hydraulic opening.  
 Opening operating pressure: 25 bar  
 Retensioning operating pressure: 20 bar  
 Cover and piston hardened.  
 Repeatability < 0.005 mm.

**NEW!**



STAINLESS STEEL

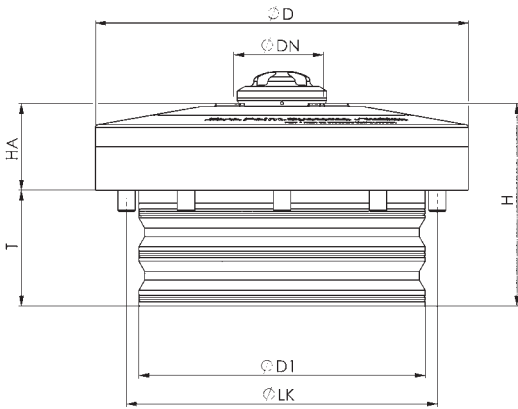
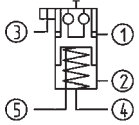

Order no.	Size	Pull-in/locking force up to	Holding force	Weight
		[kN]	[kN]	[Kg]
420919	K23	23	23	4,8

### Application:

For fully automatic clamping solutions for use as machine table support in processing centres with automatic pallet changing system or robot loading and for installation in pallets, machine tables, clamping brackets and cubes. Many possible versatile uses in automation.

### Note:

Hardened support surfaces as island design with integrated support control. Additional blowing off of the support surfaces by centrally running-out turbine spindles and blowing out of the sphere space. Additional hydraulic 6 mm lift-out of the change pallet for easier pallet removal.

Sensing options:

- Support control (pneumatic)
- Locking control (hydraulic)

Turbine has five connections:

- 1x hyd. opening (1) / 1x hyd. retensioning (2) / 1x pneum. support control (3) / 1x blow-off, blow-out and pneum. turbine blow-off (4) / 1x hyd. locking control (5).

### On request:

- Installation diagrams

### Dimensions:

Order no.	Size	dia. D	dia. DN	dia. D1	H	HA	dia. LK	T
420919	K23	129	32	99	70	30	115	40



Subject to technical alterations.



## „TURBINE“ HIGH-END CLAMPING MODULE FOR FULL AUTOMATION

This high-end clamping module is used for optimised tool clamping times in fully automatic processing centres with pallet changing systems or robot loading.

- > Turbine blow-off of the hardened support and housing surface
- > Pneumatic support control
- > Hydraulic unlocking control
- > Hydraulic lifting of the pallet (6 mm) after opening of the clamping module
- > Material: stainless steel
- > Hardened support surface on the connection fitting with defined, measurable height





The module interior is completely sealed. As a result, the system is optimally protected against liquids and dirt.



Customer solution for an increased clamping of the workpiece

Subject to technical alterations.



## No. 6202HS4 4-fach Spannstation

Hydraulic unlocking.  
Repeatability < 0.005 mm.

**NEW!**



Order no.	Size	Pull-in/locking force up to [kN]	Holding force [kN]	Weight [Kg]
421602	K10	4 x 10	4 x 25	4,5

### Application:

Clamping stations are suitable for machine tables, clamping brackets, clamping cubes, clamping towers and brackets and can be used with the continuous insertion dimension (ID) for a modular system. As a result, vices, fixtures, magnetic plates, etc. can be exchanged quickly and precisely. The clamping stations are designed for slot intervals of 50, 63 and 100 mm.

### Note:

The clamping station is opened hydraulically and mechanically locked through spring force. Then the pressure line (for opening), e.g. hydraulic hose, can be uncoupled = no interfering lines.

### On request:

- Clamping stations with installation clamping modules K5, K20 or K40.

### Dimensions

Order no.	Size	A	B	H	HA	dia. N	dia. P	S	SM	T1	T2	U1	U2
421602	K10	230	230	15	7	20 <sup>F7</sup>	13	35	100	126	200	100	200

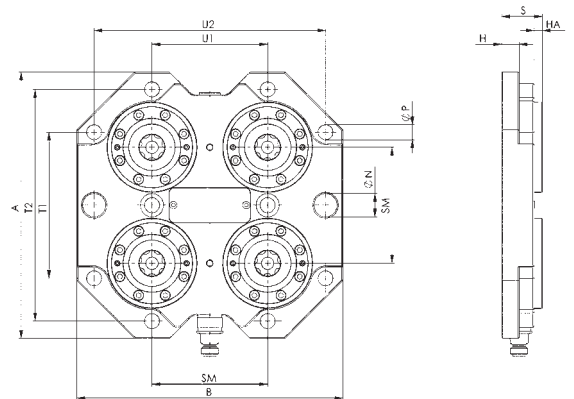

## VARIOUS POSSIBLE USES OF THE CLAMPING STATION:

The following advantages result from this solution:

- > 5-side processing by means of square module or bracket
- > Production of a workpiece with short set-up times
- > Various processing procedures on various machines with unchanged workpiece clamping
- > Possibility to index the fixture in 90° steps

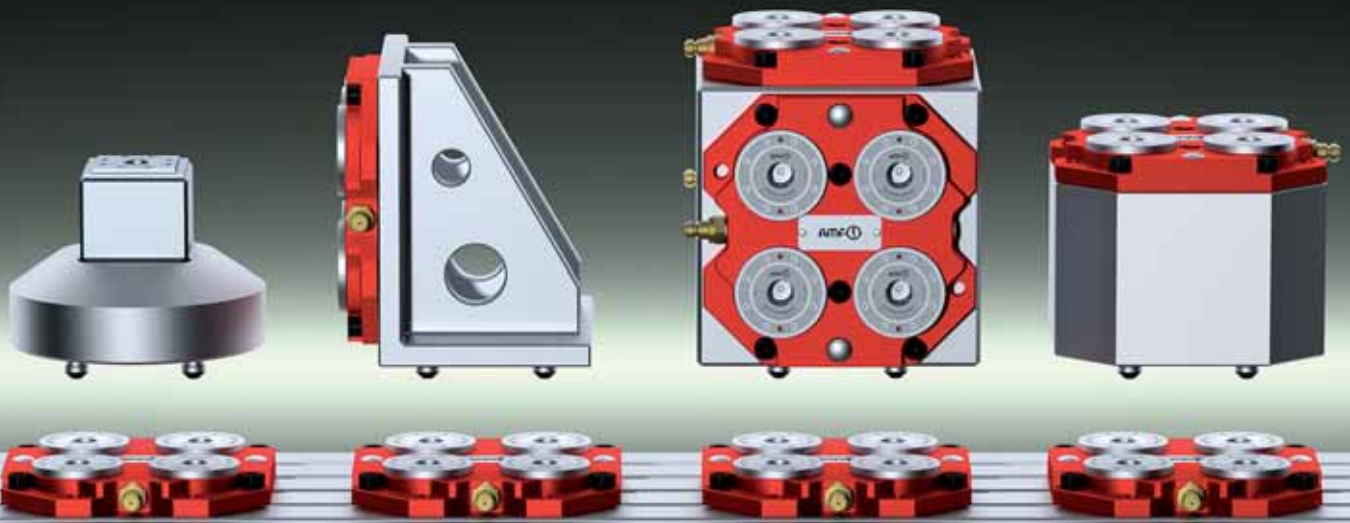

## No. 6370S2-001

### Double clamping station

Hydraulic unlocking.  
Steel, unhardened.  
Repeatability < 0.005 mm.

**NEW!**



Order no.	Size	Pull-in/locking force up to [kN]	Holding force [kN]	Weight [Kg]
303263	K20	2 x 20	2 x 55	16,5
303271	K40	2 x 40	2 x 105	32,0

#### Note:

On request, we can incorporate mounting holes to your requirements in the base plate.

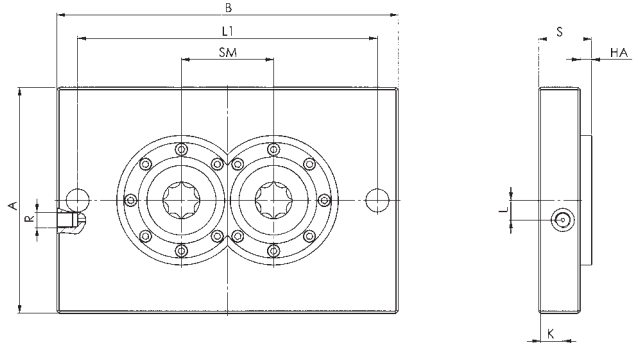

#### Dimensions

Order no.	Size	A	B	HA	K	L	L1	dia. N	R	S	SM
303263	K20	196	296	10	21	17	260	20	G1/4	46	80
303271	K40	246	346	15	30	21	300	25	G1/4	61	110

## No. 6370S2-002

### Double clamping station

Hydraulic unlocking.  
Steel, unhardened.  
Repeatability < 0.005 mm.

**NEW!**



Order no.	Size	Pull-in/locking force up to [kN]	Holding force [kN]	Weight [Kg]
426726	K10	2 x 10	2 x 25	7,5
303289	K20	2 x 20	2 x 55	21,9
303297	K40	2 x 40	2 x 105	59,5

#### Note:

On request, we can incorporate mounting holes to your requirements in the base plate. Other dimensions, gauges and number of clamping module layouts on request.

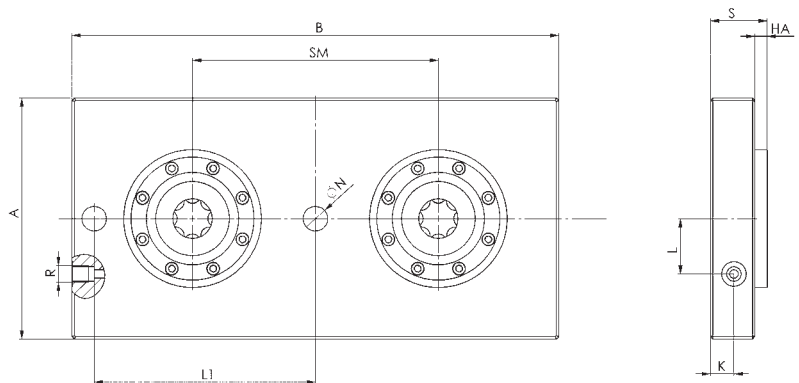

#### Dimensions

Order no.	Size	A	B	HA	K	L	L1	dia. N	R	S	SM
426726	K10	146	240	7	14,5	35	100	20	G1/4	33	100
303289	K20	196	396	10	19,0	45	180	20	G1/4	46	200
303297	K40	296	546	15	26,0	57	250	25	G1/4	61	320

Subject to technical alterations.

## No. 6370S4-001

### Quadruple clamping station

Hydraulic unlocking.  
Steel, unhardened.  
Repeatability < 0.005 mm.

**NEW!**



Order no.	Size	Pull-in/locking force up to [kN]	Holding force [kN]	Weight [Kg]
426742	K10	4 x 10	4 x 25	12,5
303321	K20	4 x 20	4 x 55	44,0
303339	K40	4 x 40	4 x 105	110,0

#### Note:

On request, we can incorporate mounting holes to your requirements in the base plate.

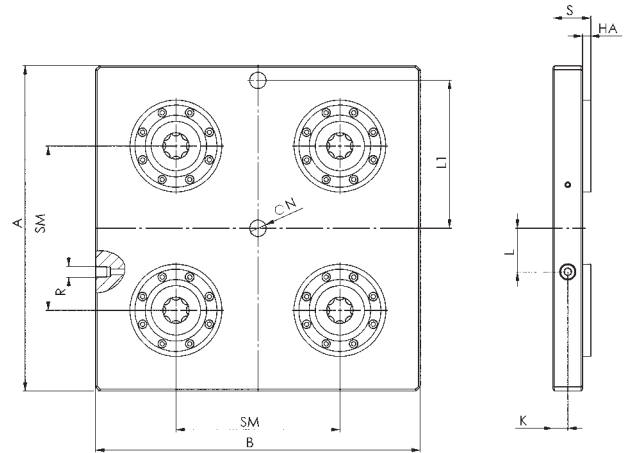

#### Dimensions

Order no.	Size	A	B	HA	K	L	L1	dia. N	R	S	SM
426742	K10	240	240	7	14,5	16	100	20	G1/4	33	100
303321	K20	396	396	10	19,0	53	180	20	G1/4	46	200
303339	K40	546	546	15	26,0	217	250	25	G1/4	61	320

## No. 6370S6-001

### Sextuple clamping station

Hydraulic unlocking.  
Steel, unhardened.  
Repeatability < 0.005 mm.

**NEW!**



Order no.	Size	Pull-in/locking force up to [kN]	Holding force [kN]	Weight [Kg]
426734	K10	6 x 10	6 x 25	17,5
424119	K20	6 x 20	6 x 55	75,0
426759	K40	6 x 40	6 x 105	175,0

#### Note:

On request, we can incorporate mounting holes to your requirements in the base plate. Other dimensions, gauges and number of clamping module layouts on request.

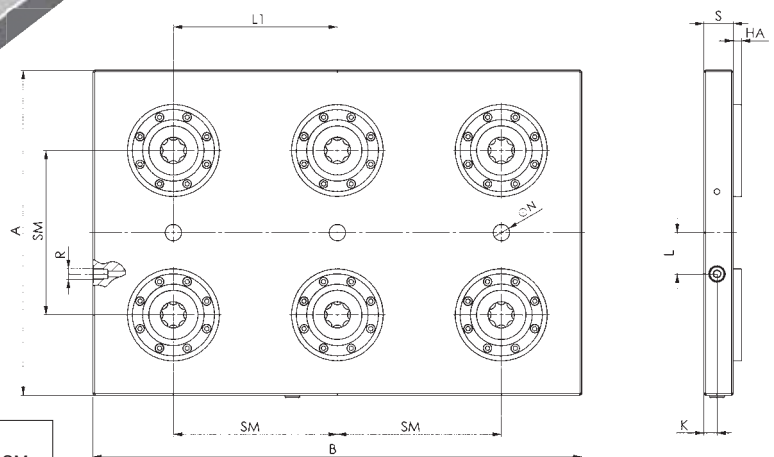

#### Dimensions

Order no.	Size	A	B	HA	K	L	L1	dia. N	R	S	SM
426734	K10	240	340	7	14,5	84	100	20	G1/4	33	100
424119	K20	396	596	10	20,0	50	200	20	G1/4	46	200
426759	K40	546	846	15	24,0	96	320	20	G1/4	61	320

## No. 6370P2

### Pallet to be changed

High-strength aluminium,  
suitable for double clamping station

**NEW!**



Order no.	Size	A	B	L	R	S	SM	Weight [Kg]
426700	K10	146	240	-	-	28	100	2,5
425041	K20	196	396	120	M12	38	200	6,0
426783	K40	296	546	120	M12	43	320	19,0

#### Note:

On request, we can incorporate mounting holes according to your specifications in the change pallet.

#### On request:

Further dimensions and grid distance.

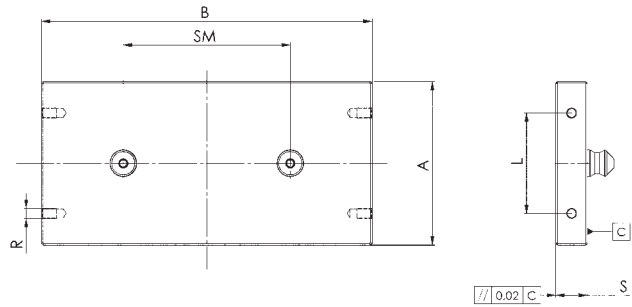

## No. 6370P4

### Pallet to be changed

High-strength aluminium,  
suitable for quadruple clamping station

**NEW!**



Order no.	Size	A	B	L	R	S	SM	Weight [Kg]
426767	K10	240	240	-	-	28	100	4,5
425033	K20	396	396	200	M12	38	200	16,0
426809	K40	546	546	320	M12	43	320	35,0

#### Note:

On request, we can incorporate mounting holes according to your specifications in the change pallet.

#### On request:

Further dimensions and grid distance.

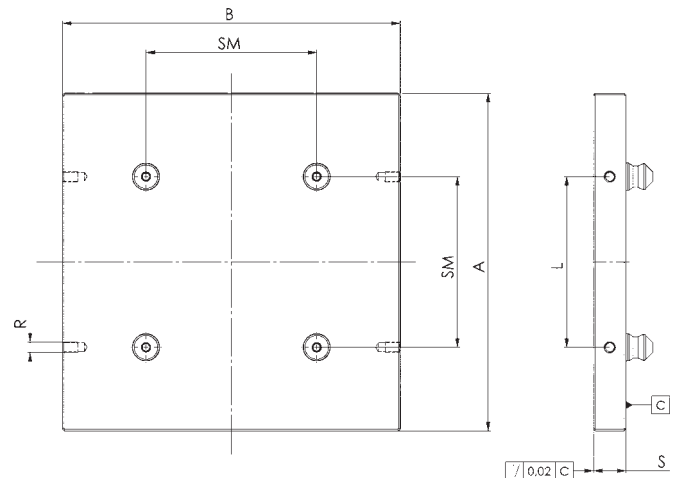

## No. 6370P6

### Pallet to be changed

High-strength aluminium,  
suitable for sextuple clamping station

**NEW!**

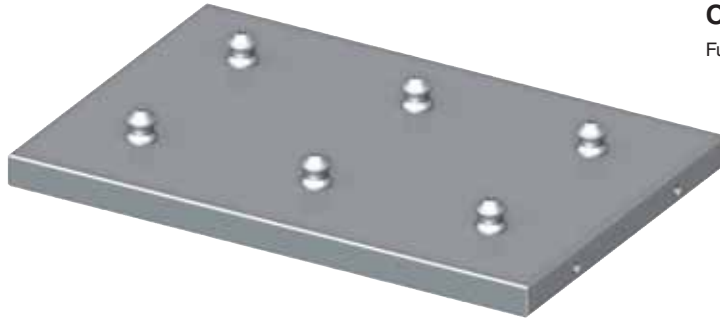

Order no.	Size	A	B	L	R	S	SM	Weight [Kg]
426775	K10	240	386	120	M10	28	100	7,5
426791	K20	396	596	200	M12	38	200	25,0
426817	K40	546	866	320	M12	43	320	56,0

### Note:

On request, we can incorporate mounting holes according to your specifications in the change pallet.

### On request:

Further dimensions and grid distance.

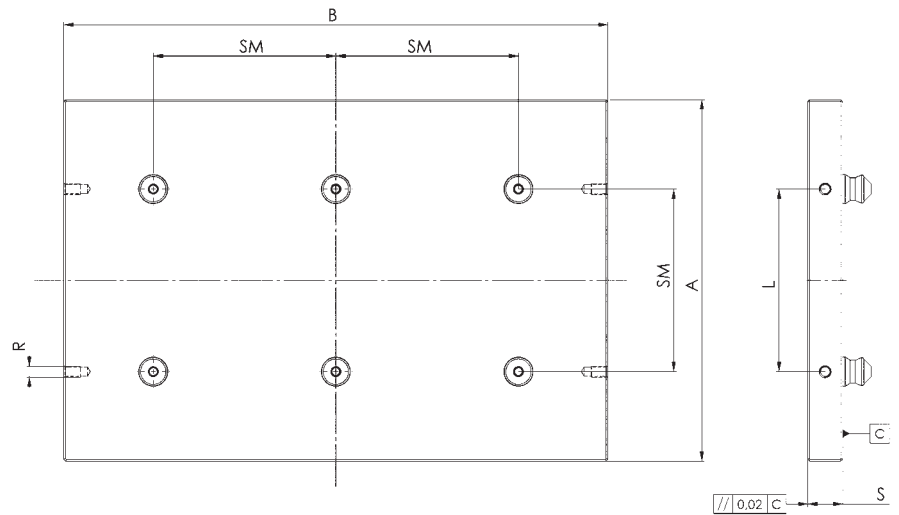

Subject to technical alterations.

## No. 6370ZN-5

### Clamping nipple for clamping modules K5

Hardened, for hydraulic and pneumatic clamping modules size K5



STAINLESS STEEL



Order no.	Size	dia. DN	dia. D1	dia. D2	H	H1	M	T	Weight [g]
306019	K 5	15,0	10	6	12,7	10,2	-	2,5	15
306035	K 5	15,0	10	6	12,7	10,2	-	2,5	15
306050	K 5	14,8	10	6	12,7	10,2	-	2,5	15
306076	K 5	14,8	-	-	-	-	M 6	-	12

#### Design:

Order no. 306019: Zero point nipple  
 Order no. 306035: Slit nipple  
 Order no. 306050: Undersized nipple  
 Order no. 306076: Protection nipple

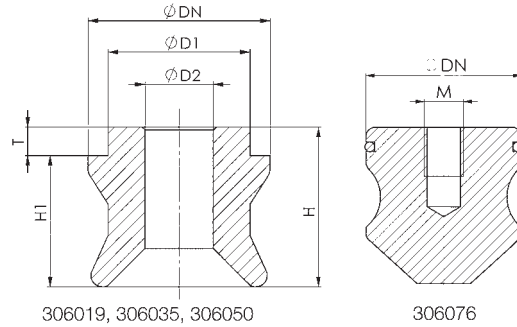

## No. 6370ZN-10

### Clamping nipple for clamping modules K10

Hardened, for hydraulic and pneumatic clamping modules size K10



STAINLESS STEEL

Order no.	Size	dia. DN	dia. D1	dia. D2	H	H1	M	T	Weight [g]
303610	K10	22,0	15	8	19	16	-	3	30
303636	K10	22,0	15	8	19	16	-	3	30
304519	K10	21,8	15	8	19	16	-	3	30
304535	K10	21,8	-	-	-	-	M 8	-	30

#### Design:

Order no. 303610: Zero point nipple  
 Order no. 303636: Slit nipple  
 Order no. 304519: Undersized nipple  
 Order no. 304535: Protection nipple

## No. 6370ZN-20

### Clamping nipple for clamping modules K20

Hardened, for hydraulic and pneumatic clamping modules size K20



STAINLESS STEEL

Order no.	Size	dia. DN	dia. D1	dia. D2	H	H1	M	T	Weight [g]
303149	K20	32,0	25	12	28	23	-	5	110
303156	K20	32,0	25	12	28	23	-	5	110
303164	K20	31,8	25	12	28	23	-	5	110
303172	K20	31,8	-	-	-	-	M 8	-	110

#### Design:

Order no. 303149: Zero point nipple  
 Order no. 303156: Slit nipple  
 Order no. 303164: Undersized nipple  
 Order no. 303172: Protection nipple

## No. 6370ZN-40

### Clamping nipple for clamping modules K40

Hardened, for hydraulic and pneumatic clamping modules size K40



STAINLESS STEEL

Order no.	Size	dia. DN	dia. D1	dia. D2	H	H1	M	T	Weight [g]
303180	K40	40,0	25	16	34	29	-	5	180
303198	K40	40,0	25	16	34	29	-	5	180
303206	K40	39,8	25	16	34	29	-	5	180
303214	K40	39,8	-	-	-	-	M 8	-	180

#### Design:

Order no. 303180: Zero point nipple  
 Order no. 303198: Slit nipple  
 Order no. 303206: Undersized nipple  
 Order no. 303214: Protection nipple

## CLASSIC CLAMPING NIPPLE ARRANGEMENT

This arrangement of the clamping modules always optimally positions the pallet to be changed. At the same time, the zero-point nipple always represents the reference point. The slit nipple serves to compensate for the free axis. The undersize nipple has only a clamping and holding function.

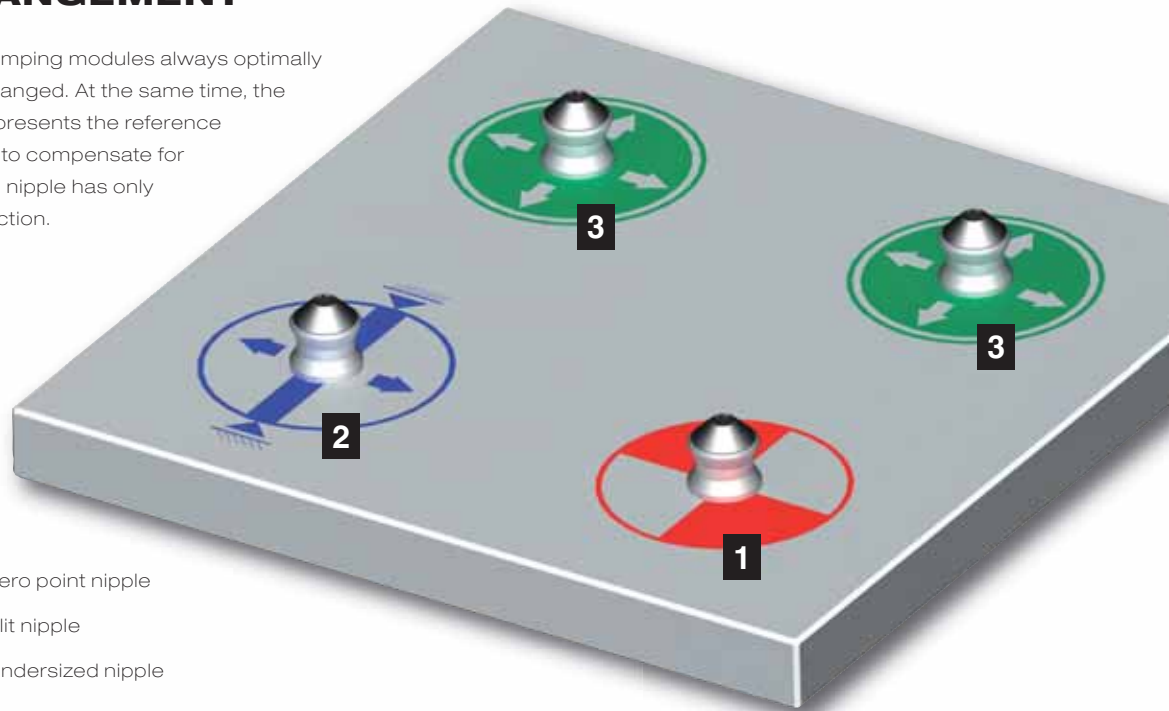

- 1** Zero point nipple
- 2** Slit nipple
- 3** Undersized nipple

## OPTIONAL CLAMPING NIPPLE ARRANGEMENT

This arrangement of the clamping nipples compensates for stronger temperature influences. The reference point always remains in the centre of the pallet.

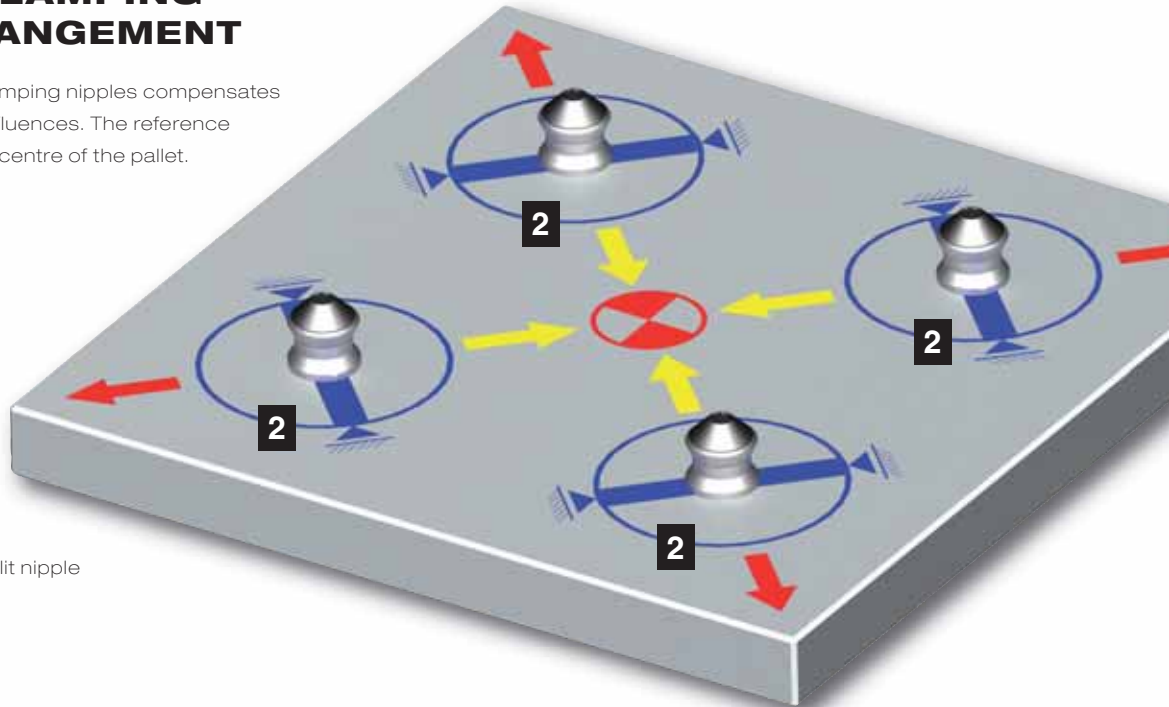

- 2** Slit nipple

## No. 6370ZNS-001

### Engagement nipple screw

Strength class 10.9.  
Suitable for clamping nipple article-nos. 6370ZN.

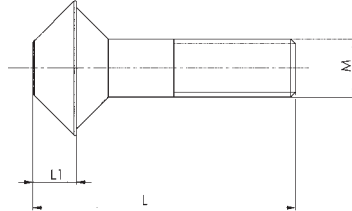

Order no.	Size	M	L	L1	Weight [g]
306092	K 5	M 6	25	3,4	18
303578	K10	M 8	37	6,0	30
303222	K20	M12	54	9,0	70
303230	K40	M16	69	10,0	130

#### On request:

Engagement nipple screws in various lengths and materials (e.g. high-grade stainless steel).

## No. 6370ZNS-002

### Horizontal engagement nipple screw

Strength class 10.9.  
Suitable for clamping nipple article-nos. 6370ZN.

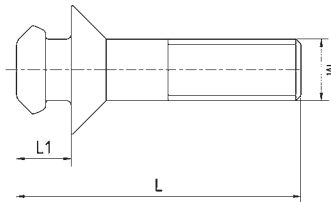

Order no.	Size	M	L	L1	Weight [g]
303248	K20	M12	56	10,5	100
303255	K40	M16	73	13,0	200

#### On request:

Horizontal engagement nipple screw in various lengths and materials (e.g. high-grade stainless steel).

## Dimensions for machining nipple mountings

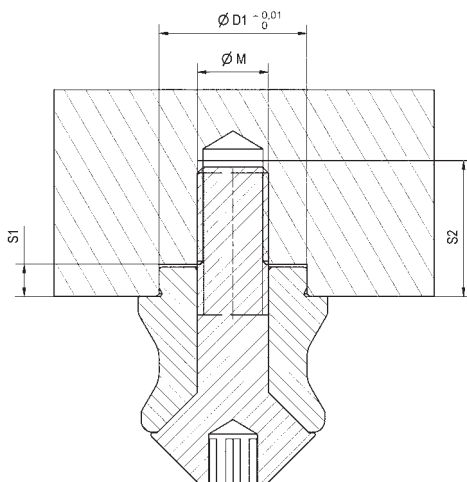

Size	dia. D1	dia. M	S1	S2
K5	10	M 6	2,5	12
K10	15	M 8	3,5	16
K20	25	M12	5,5	23
K40	25	M16	5,5	30

#### Figure:

Shown with clamping nipple and engagement nipple screw.



## No. 6370ZNI

### Clamping nipple for internal thread

Hardened, for hydraulic and pneumatic clamping modules size K20.

**NEW!**



Order no.	Size	dia. DN	dia. D1	H	M	S1	U	T	Weight [g]
427021	K20	32,0	25	37	M12	5,5	18	5	136
427047	K20	32,0	25	37	M12	5,5	18	5	136
427062	K20	31,8	25	37	M12	5,5	18	5	136

### Design:

Order no. 427021: Zero point nipple

Order no. 427047: Slit nipple

Order no. 427062: Undersized nipple

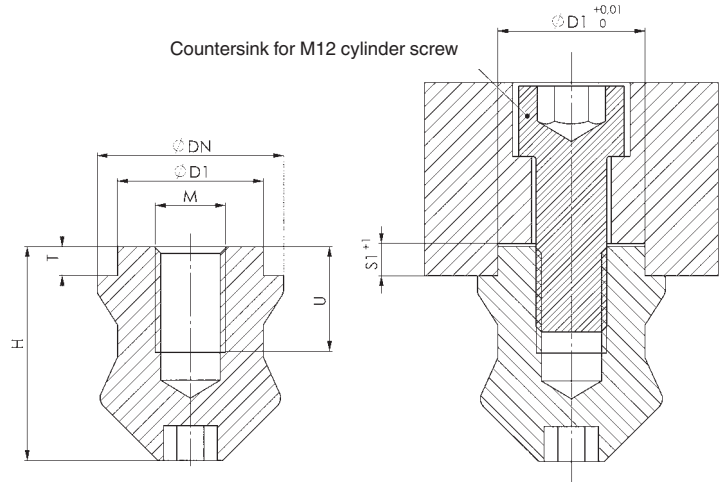

## No. 6370ZNSN

### Floating nipple

Hardened, for hydraulic and pneumatic clamping modules.

**NEW!**



Order no.	Size	dia. DN	dia. D2	H1	Weight [g]
340059	K10	21,8	12,0	16	25
305912	K20	31,8	15,5	23	80
426882	K40	39,8	20,0	29	160

### Note:

The floating nipple is supported by bearings so that it is axially mobile and is used when large distance and angle tolerances between the nipple holes have to be compensated. The nipple has only a holding function and does not take on any lateral load.

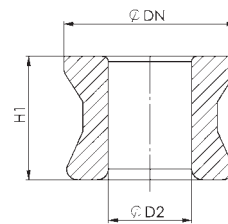

## No. 6370ZNSSN

### Engagement nipple screw

Strength class 10.9.

Suitable for floating nipple, article no. 6370ZNSN.

**NEW!**



Order no.	Size	dia. D2	M	L	L1	L2	L3	Weight [g]
340034	K10	11,0	M8	35	6	16,1	12,9	24
305938	K20	13,5	M10	50	9	23,1	17,9	55
426908	K40	17,0	M12	59	10	29,1	19,9	100

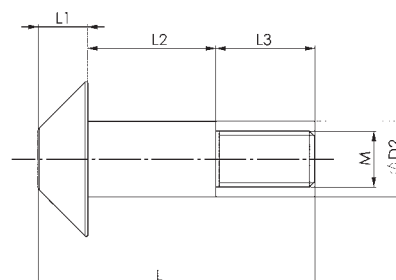

Subject to technical alterations.

## No. 6201ZN

### Clamping nipple for installation clamping module, „heavy-duty“

Hardened, for hydraulic clamping modules article-nos. 6201H-20.

**NEW!**



Order no.	Size	dia. DN	dia. D1	dia. D2	H	H1	M	T	Weight [g]
423970	K20	32,0	25	16	28	23	-	5	80
423996	K20	32,0	25	16	28	23	-	5	80
424010	K20	31,8	25	16	28	23	-	5	80
303172	K20	31,8	-	-	-	-	M 8	-	110

#### Design:

Order no. 423970: Zero point nipple  
Order no. 423996: Slit nipple  
Order no. 424010: Undersized nipple  
Order no. 303172: Protection nipple

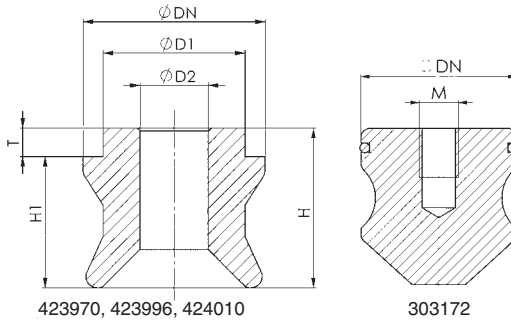

## No. 6201ZS

### Engagement nipple screw „heavy duty“

Strength class 10.9.  
Suitable for clamping nipple article-nos. 6201ZN.

**NEW!**



Order no.	Size	M	L	L1	Weight [g]
424036	K20	M16	70	9	120

#### On request:

Engagement nipple screws in various lengths and materials (e.g. high-grade stainless steel).

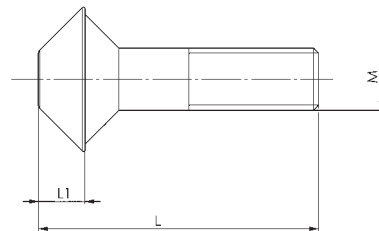

## No. 6370ZA

### Protective shield

made of tempering steel,  
suitable for article-nos. 6370 A, E, S.

**NEW!**



Order no.	Size	dia. D	dia. D1	HA	T	Weight [g]
422345	K10	50	15	7	3	100
422360	K20	76	25	10	5	340
422386	K40	112	25	15	5	1130

### Application:

The protective shield is used when through-holes must be set in the area of the module cover. As a result, the module cover is protected from damage.

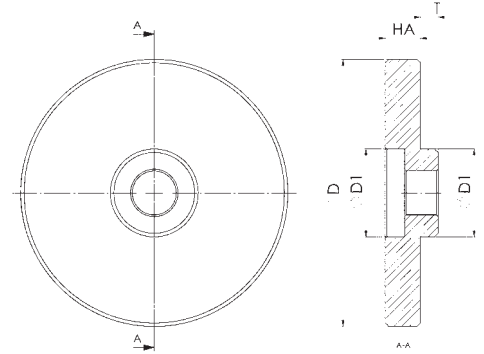

## No. 6370ZNSA

### Engagement nipple screw for protective shield

Strength class 10.9.  
Suitable for article-nos. 6370 A, E, S.

**NEW!**



Order no.	Size	M	L	L1	Weight [g]
422402	K10	M8	44	6	33
422428	K20	M12	64	9	80
422444	K40	M16	84	10	145

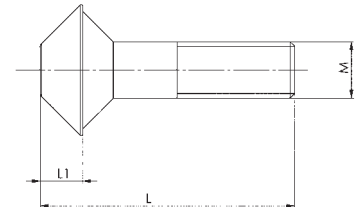

Subject to technical alterations.

## No. 6102ZN

### Clamping nipple for „Turbine“ high-end clamping module

Hardened, for hydraulic high-end clamping module article no. 6102H.

**NEW!**



Order no.	Size	dia. DN	dia. D1	dia. D2	dia. D3	dia. LK	H	H1	H2	T	Weight [g]
426502	K23	32,0	25	68	6,4	50	38	23	10	5	370
426528	K23	32,0	25	68	6,4	50	38	23	10	5	370
426544	K23	31,8	25	68	6,4	50	38	23	10	5	370

#### Design:

Order no. 426502: Zero point nipple

Order no. 426528: Slit nipple

Order no. 426544: Undersized nipple

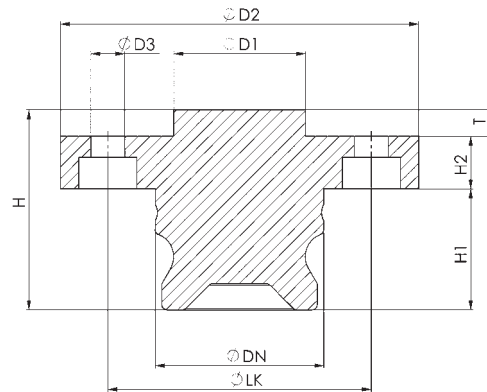

## No. 6370ZZ

### Positioning gauge

Hardened.



Order no.	for clamping modules	dia. D1	dia. DN	H	Weight [g]
306241	K 5	8	15	48	60
306167	K10	12	22	48	85
306183	K20 / G1000	16	32	64	225
306209	K40	20	40	82	455
306225	G2000	20	47	82	550

#### Application:

The positioning gauge is used to align surface-mounted modules. It can be clamped directly in the machine spindle, thus achieving the desired position when the machine is traversed.

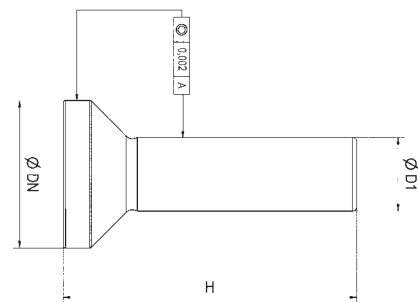

## No. 6370ZMSH

### Mounting key for horizontal rapid-clamping cylinder

Suitable for article-nos. 6370HARH.

**NEW!**



Order no.	Size	Weight [g]
424556	K20	520
426866	K40	940

#### Application:

The mounting key is needed for installation of the threaded guide pin of the horizontal rapid-clamping cylinder.

## No. 6984-30

### Support control, pneumatic

max. operating pressure 10 bar.  
Suitable for hydraulic and pneumatic clamping modules size K20.

**NEW!**

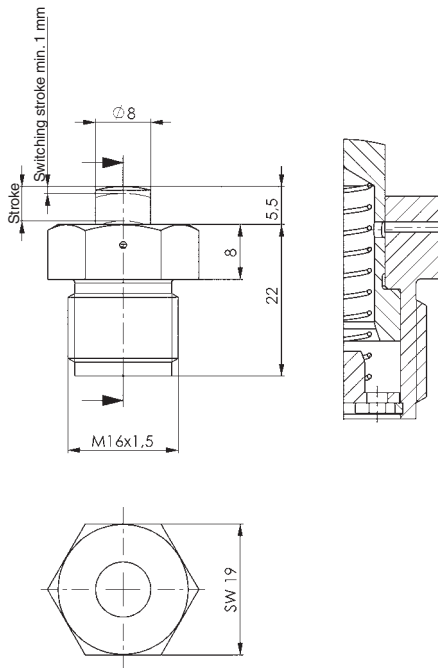

Order no.	Stroke max. [mm]	Spring force min. [N]	Spring force max. [N]	Weight [g]
325217	5	1,9	2,6	56

### Application:

The support control is used in fixtures where a signal indicating a correctly supported workpiece is required to enable machining. Light-weight workpieces should be clamped before being pressurised with compressed air.

### Features:

The support control works like a pneumatic back-pressure nozzle. The position is extended from its initial position by a pressure spring. Once applied, the air jet flows through the hollow piston and the radial discharge hole on the support control housing to outside. The discharge hole is sealed as soon as a workpiece is mounted and the piston is pushed downwards by min. 1 mm. The air flow backs up, the internal air pressure rises. The pressure value must be transferred to the control by an appropriate pressure signal converter. The system is relatively insensitive to fine chips.

### Note:

The pressure signal converter is not included in the supply scope.  
Effective piston surface with closed nozzle = 0.95 cm<sup>2</sup>  
Piston force = piston surface x air pressure + spring force

### Installation drawing

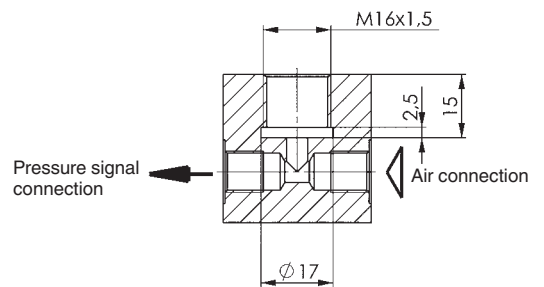

## No. 6370ZMMG

### Coupling mechanism adapter

Suitable for installation clamping module nos. 6370FARH / FARL.

**NEW!**

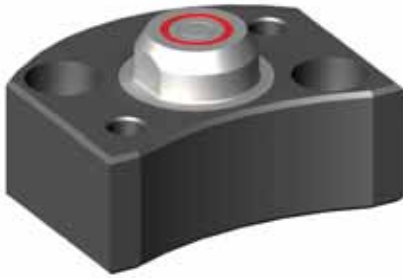

Order no.	Size	Nominal bore [NW]	A	A1	A2	B	HA	K	dia. N	dia. P	R	T	U	Weight [kg]
424002	K20	5	56	33	18	65	35	13	6 <sup>H7</sup>	9	G1/8	12	45	0,9
424184	K40	5	56	33	18	65	45	13	6 <sup>H7</sup>	9	G1/8	12	45	1,0

#### Application:

Couplings are used for loss-free transfer of liquid and gaseous media and are adjusted to the cover height of the installation clamping modules.

#### Note:

The coupling mechanism and nipple must be guided approx. 2-3 mm before contact with the axial sealing surfaces. The radial position tolerance (+/- 0.2mm) must not be exceeded. The couplings can only be coupled in a depressurised state.

The separating force due to hydraulic pressure between the coupling nipple and mechanism is given by the formula  $F [N] = 15.4 \times p [\text{bar}]$  and must be taken into account.

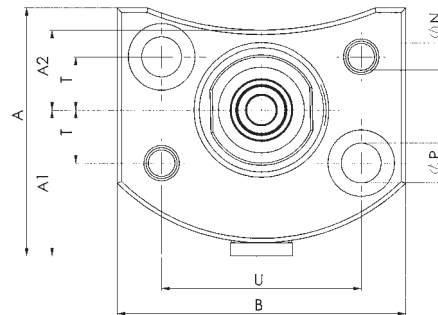
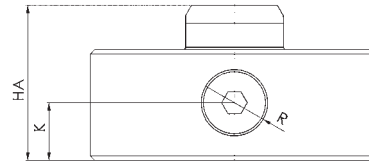

## No. 6989N

### Screw-in coupling nipple

max. operating pressure 400 bar.



Order no.	Nominal bore [NW]	A	dia. B	G	dia. H	K	L	Weight [g]
164988	5	M24x1,5	20	27	13,5	14	4,5	56

#### Application:

Couplings are used for the leakage-free connection of hydraulic oil supplies.

#### Note:

The coupling mechanism and nipple must be guided approx. 2-3 mm before contact with the axial sealing surfaces. The radial position tolerance (+/- 0.2 mm) must not be exceeded. The couplings can only be coupled in a depressurised state. The separating force due to hydraulic pressure between the coupling nipple and mechanism is given by the formula  $F [N] = 15.4 \times p [\text{bar}]$  and must be taken into account.

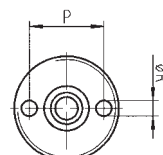
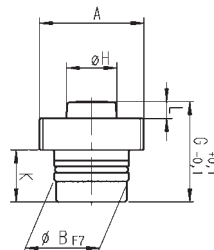

Subject to technical alterations.

## No. 6370ZMNG

### Coupling nipple adapter

Suitable for coupling mechanism  
no. 6370ZMMG / ZMM

**NEW!**



Order no.	Size	Nominal bore [NW]	dia. A	B	C	D	G	K	dia. P	T	U	Weight [g]
424242	K20	5	35	35	60	20	47,5	43,5	5,5	20	40	320

#### Application:

The coupling nipple adapter is the counterpart to the coupling mechanicals and is used in the change pallet, in which the clamping nipples are also located. Couplings are used for loss-free transfer of liquid and gaseous media and are adjusted to the height of the installation clamping modules.

#### Note:

The mounting housings of the two parts must be guided approx. 2-3 mm before contact with the axial sealing surfaces. This function is taken over by the coupling nipple adapter through the centring function. The medium can be passed on at the top over the pipe connection or over the O-ring connection. The radial position tolerance (+/- 0.2 mm) must not be exceeded. The couplings can only be coupled in a depressurised state. The separating force due to hydraulic pressure between the coupling nipple and mechanism is given by the formula  $F [N] = 15.4 \times p [\text{bar}]$  and must be taken into account.

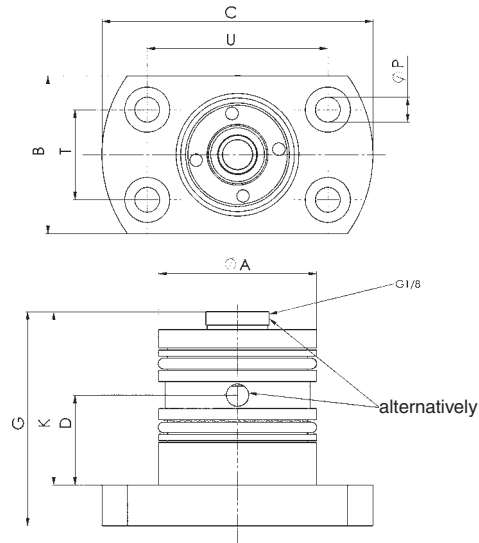

## No. 6370ZMM

### Screw-in coupling mechanism

max. operating pressure 400 bar.

**NEW!**



Order no.	Size	Nominal bore [NW]	A	dia. B	C	G	K	dia. P	SW	Weight [g]
424267	K10	5	M30x1,5	24	19	29,0	7	25	22	74
424200	K20	5	M30x1,5	24	19	29,0	10	25	22	65
424226	K40	5	M30x1,5	24	24	31,5	15	25	22	96

#### Application:

Couplings are used for loss-free transfer of liquid and gaseous media and are adjusted to the cover height of the installation clamping modules.

#### Note:

The coupling mechanism and nipple must be guided approx. 2-3 mm before contact with the axial sealing surfaces. The radial position tolerance (+/- 0.2 mm) must not be exceeded. The couplings can only be coupled in a depressurised state. The separating force due to hydraulic pressure between the coupling nipple and mechanism is given by the formula  $F [N] = 15.4 \times p [\text{bar}]$  and must be taken into account.

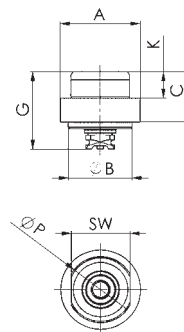

## No. 6370ZD

### Pressure intensifier

Max. operating pressure 60 bar.

**NEW!**



Order no.	Size	Oil capacity [cm <sup>3</sup> ]	Flow rate [cm <sup>3</sup> /min.]	Rato	max. no. of clamping cylinders	Weight [Kg]
303354	2	653	431	1 : 8,1	36 (Typ 20), 16 (Typ 40)	9,5

#### Design:

Compact, air-pressure-operated hydraulic pressure intensifier for single-acting circuits. Complete with air-pressure regulator, air manometer, oil manometer and oil fill level display.

#### Application:

The pressure intensifier is used for opening for hydraulic clamping modules or hydraulic clamping stations.

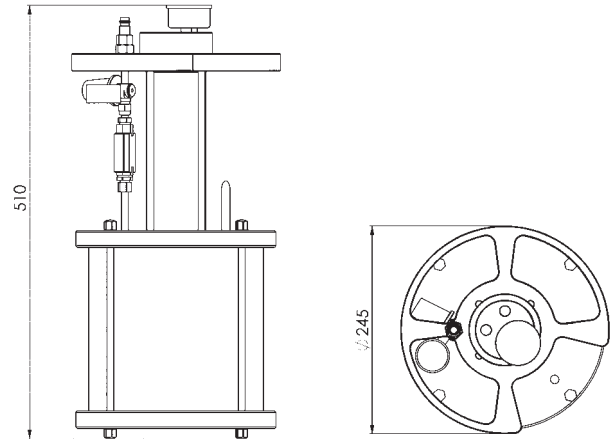

## No. 6370ZD-004

### Air-Hydraulic Pump

Max. operating pressure 60 bar.

**NEW!**



Order no.	Pneum. pressure min. [bar]	Pneum. pressure max. [bar]	Oil capacity usable horizontal [l]	Oil capacity usable vertical [l]	Flow rate max. [cm <sup>3</sup> /min.]	Weight [kg]
426569	2,8	10,0	2,1	1,5	1400	6,3

#### Design:

Compact, air-pressure-operated hydraulic intensification pump for single-acting circuits. The pump contains an air filter at the air inlet and an internal oil filter to protect the motor from contamination. Safety valve against overpressure and sound absorber. Care for correct air bleeding of connected hydraulic components.

#### Application:

The air-hydraulic pump is used for opening for hydraulic clamping modules or hydraulic clamping stations.

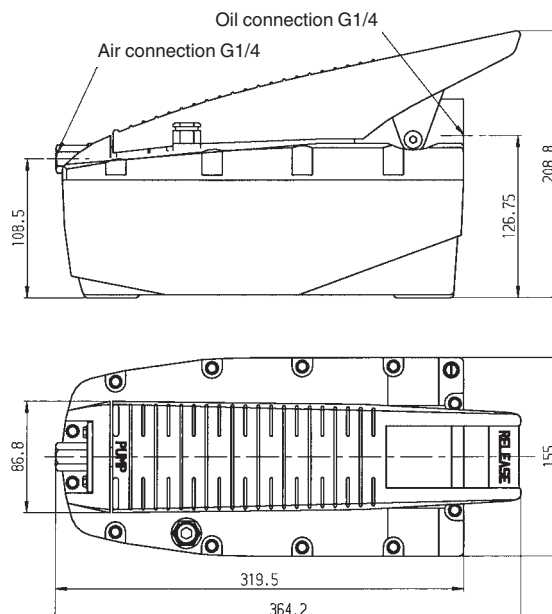

Subject to technical alterations.



**No. 6370ZVL-005**  
**Pneumatic pressure booster**

**NEW!**



Order no.	Input pressure [bar]	Output pressure [bar]	Connection	Weight [kg]
427088	2,5-8	4,5-10	G1/4	1,5

**Application:**

For strengthening the operating pressure with pneumatic clamping modules and compensation for pressure fluctuations in the supply line.

**Design:**

Pressure intensifier with possibility to adjust the pneumatic output pressure, incl. manometer construction kit, sound absorbers and flange mounting.

**Note:**

The pressure intensifier can be mounted in every installation position. For operation, filtered (40µm), unlubricated compressed air as per ISO 8573-1 is required. The pressure intensifier is suitable for ambient temperatures of +5 – +60°C.

**No. 6370ZVL-004**  
**Pneumatic pressure booster set**

**NEW!**



Order no.	Input pressure [bar]	Output pressure [bar]	Connection	Weight [kg]
421396	2,5-8	4,5-10	G1/4	2,5

**Application:**

For strengthening the operating pressure with pneumatic clamping modules and compensation for pressure fluctuations in the supply line.

**Design:**

Pressure intensifier group with possibility to adjust the pneumatic output pressure, incl. manometer construction kit, sound absorbers, flange mounting, pressure control valve, manual direction valve, coupling plug, connections and plastic tube.

**Note:**

The pressure intensifier can be mounted in every installation position. For operation, filtered (40µm), unlubricated compressed air as per ISO 8573-1 is required. The pressure intensifier sub-assembly is suitable for ambient temperatures of +5 – +60°C.

**No. 6370ZVL-006**  
**Pneumatic pressure booster cabinet**

**NEW!**



Order no.	Input pressure [bar]	Output pressure [bar]	B x H x T [mm]	Connection	Weight [kg]
427104	2,5-8	4,5-10	200 x 300 x 155	G1/4	7,0

**Application:**

For strengthening the operating pressure with pneumatic clamping modules and compensation for pressure fluctuations in the supply line.

**Design:**

Connection-ready pressure-intensifier cabinet with possibility to adjust the pneumatic output pressure.

**Note:**

The connection-ready pressure intensifier cabinet is shipped with wall-mounting bracket and can be mounted in every installation position. For operation, filtered (40µm), unlubricated compressed air as per ISO 8573-1 is required. The pressure cabinet is suitable for ambient temperatures of 0 – +40°C.

## No. 6370ZR

### Pipe fittings, brass

for brass pipes external Ø 8 mm, internal Ø 6 mm. Max. operating pressure 100 bar.

#### Note:

- \* No. 320960:
- \* brass made pipe, dia 8x1, lenght 2.500, CuZn37 hard F45 DIN 17660 seamless. Mounting and sealing by cutting ring.

#### Application:

Fittings for piping of surface-mounted clamping modules and flange versions.

Order no.	Figure	R	Weight [g]
320986	1	G1/4	80
305409	1	G1/8	44
321000	2	G1/4	31
305417	2	G1/8	23
321026	3	G1/4	95
305425	3	G1/8	60
321042	4	-	37
321067	5	-	56
320960	*	*	475

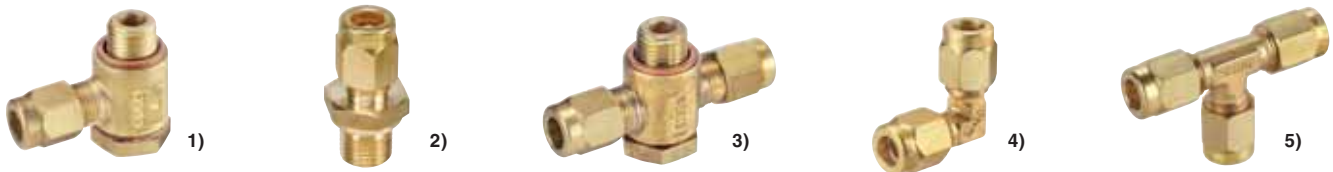

## No. 6985R

### High Pressure Hose

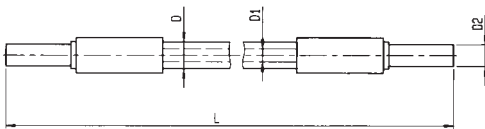

Order no.	Test pressure [bar]	Operating pressure dyn. at +50 °C [bar]	dia. D [mm]	dia. D1 [mm]	dia. D2 [mm]	L [mm]	Weight [g]
63206	750	375	9,8	4,8	8	500	90
63214	750	375	9,8	4,8	8	800	120
63222	750	375	9,8	4,8	8	1250	180
63230	750	375	9,8	4,8	8	2000	265
63248	750	375	9,8	4,8	8	3000	380

Bending radius = min. 30 mm

#### Design

Steel fitting, galvanized and passivated. Hose of synthetic material with high tensile braided steel-wire braid.

#### Application:

High pressure hose, for connecting oil supply to surface mounting modules or clamping stations.

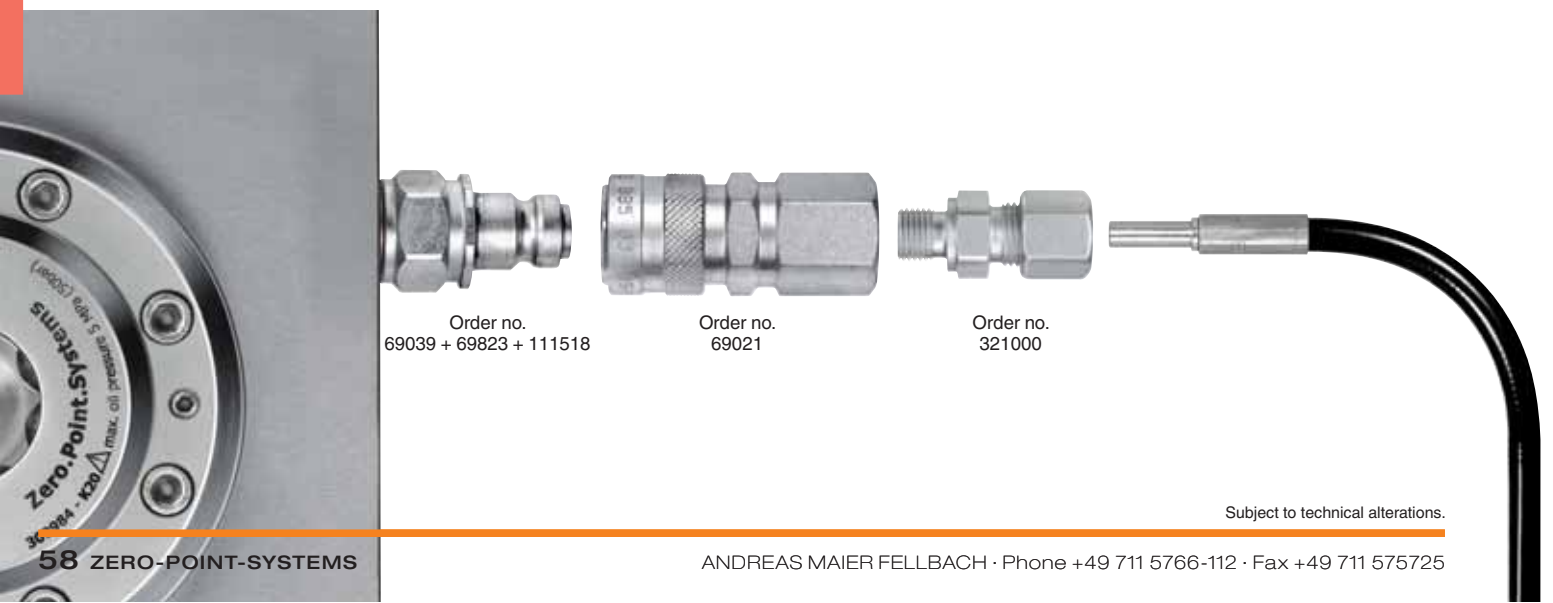

Subject to technical alterations.

## No. 6988

### Manifold

Steel, burnished.  
Max. operating pressure 400 bar.



Order no.	Nominal bore [NW]	A	B	C	R	Oil connections	Weight [g]
68825	6	-	50	30	G1/4	4	480
68817	6	200	50	30	G1/4	6	2025

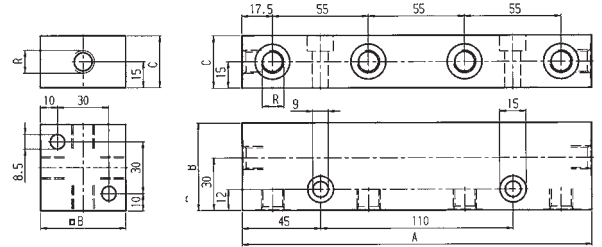

## No. 6990

### Quick Disconnect Coupler

galvanized.  
Max. operating pressure 400 bar.



Order no.	Nominal bore [NW]	Nominal flow [l/min]	SW [mm]	Weight [g]
69021	4	7,5	24	190
69039	4	7,5	22	60

### Design

Since clamping modules are locking mechanically, hydraulic supply can be cut off when clamping process is completed.

## No. 6990MK/SK

### AI Protection

for quick disconnect coupler.



Order no.	Weight [g]
65508	190
65524	60

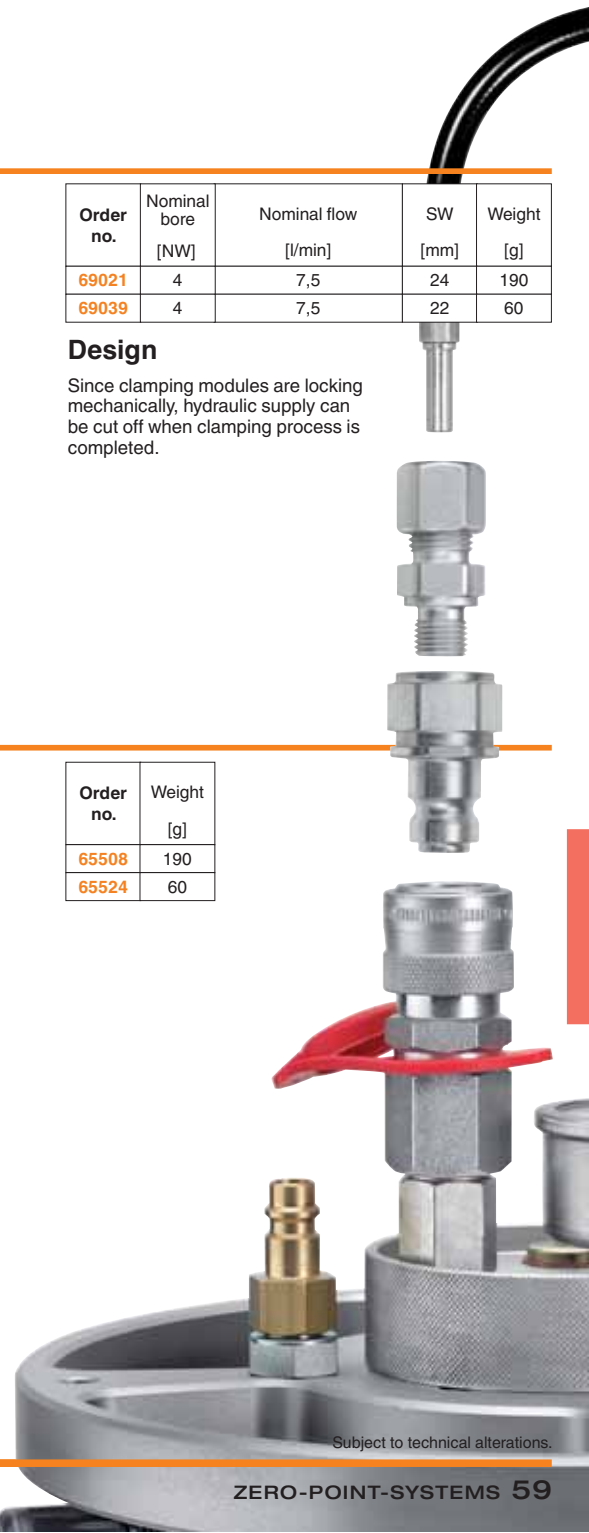

Subject to technical alterations.

## No. 6370ZF

Special grease for zero-point clamping modules

**NEW!**



Order no.	Suitable for ambient temperature [°C]	Weight [g]
426494	0 - 80	250

### Application:

Special grease for maintenance work on zero-point clamping modules.

## No. 6370ZVL

Manual directional valves



Order no. 305383

Order no. 305391

Order no.	Type	Air connection	Weight [g]
305383	4/3	G1/4	250
305391	2/2	G1/4	100

Circuit: hydraulic clamping module

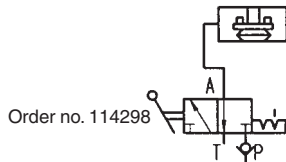

Order no. 114298

Circuit: hydraulic clamping module with blow-out

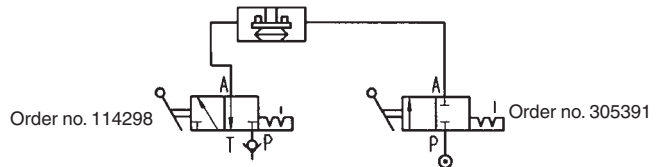

Order no. 114298

Order no. 305391

Circuit: pneumatic clamping module

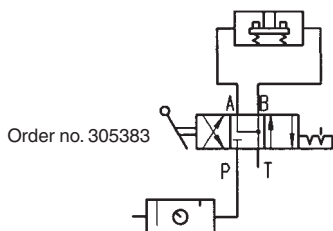

Order no. 305383

Circuit: pneumatic clamping module with turbo and blow-out

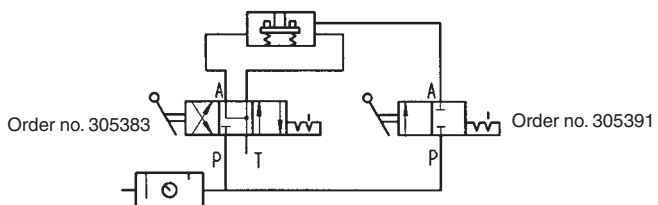

Order no. 305383

Order no. 305391

Subject to technical alterations.

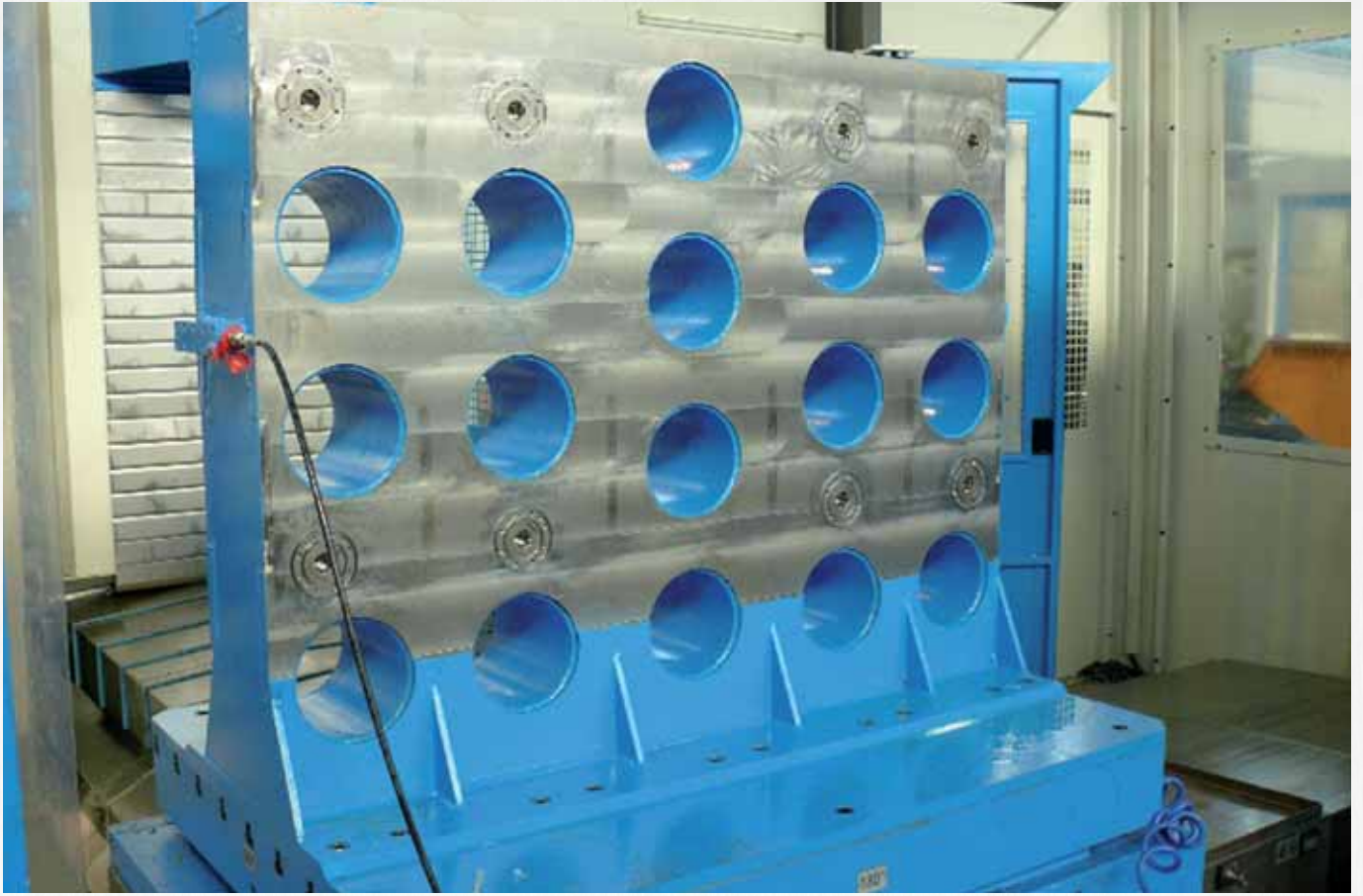

# YOU ALREADY HAVE A CLAMPING SYSTEM?!

## YOU CAN STILL TAKE ADVANTAGE OF OUR BENEFITS ...

With our „Gonzales“ and „Unitool“ clamping modules, we offer you flexibility in retrofitting and expanding your existing zero-point clamping technology. As a result, a complete replacement of the system you currently use is no longer absolutely necessary. You keep your investment as low as possible and still take advantage of the benefits of the AMF Zero-Point System.



### „GONZALES“ CLAMPING MODULE (FIG. LEFT)

Your existing Speedy 1000/2000 or DockLock 1000 modules can be exchanged for our corresponding „Gonzales“ modules if you meet the following requirements:

- > Unlike Speedy 1000/2000 and DockLock 1000, „Gonzales“ requires a hydraulic unclamping pressure of min. 50 bar / max. 60 bar.
- > With countersunk installation, replacement is only possible if there is enough space for the larger covers of the „Gonzales“ modules (cover dia. 112 mm or 140 mm).
- > Modules with media ducts cannot be exchanged
- > Use „Gonzales“ modules exclusively with „Gonzales“ modules in one clamping.

With the „Gonzales“ modules, the corresponding nipples of the systems Speedy 1000/2000 and DockLock 1000 can be clamped.

„Gonzales“ nipples can be clamped with the corresponding Speedy 1000/2000 and DockLock 1000 modules.

### „UNITOOL“ CLAMPING MODULE (FIG. RIGHT)

Our „Unitool“ clamping module fits the nipple of the Unilock system (dia. 40 mm). The Unitool nipple also fits the Unilock system module (NSE-138).

### RUSTPROOF STAINLESS STEEL



High-alloy, hardened tool steel - and so no corrosion.

### SAFETY SYSTEM

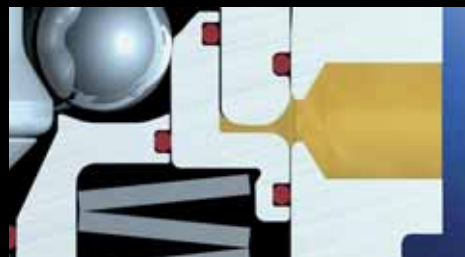

Process reliability - Clamping module always opens. A piston blockade is thus impossible (only Gonzales modules).

### FORM FIT



The balls are optimally encapsulated on 3 sides. As a result, the clamping nipple always remains firmly clamped in the module.

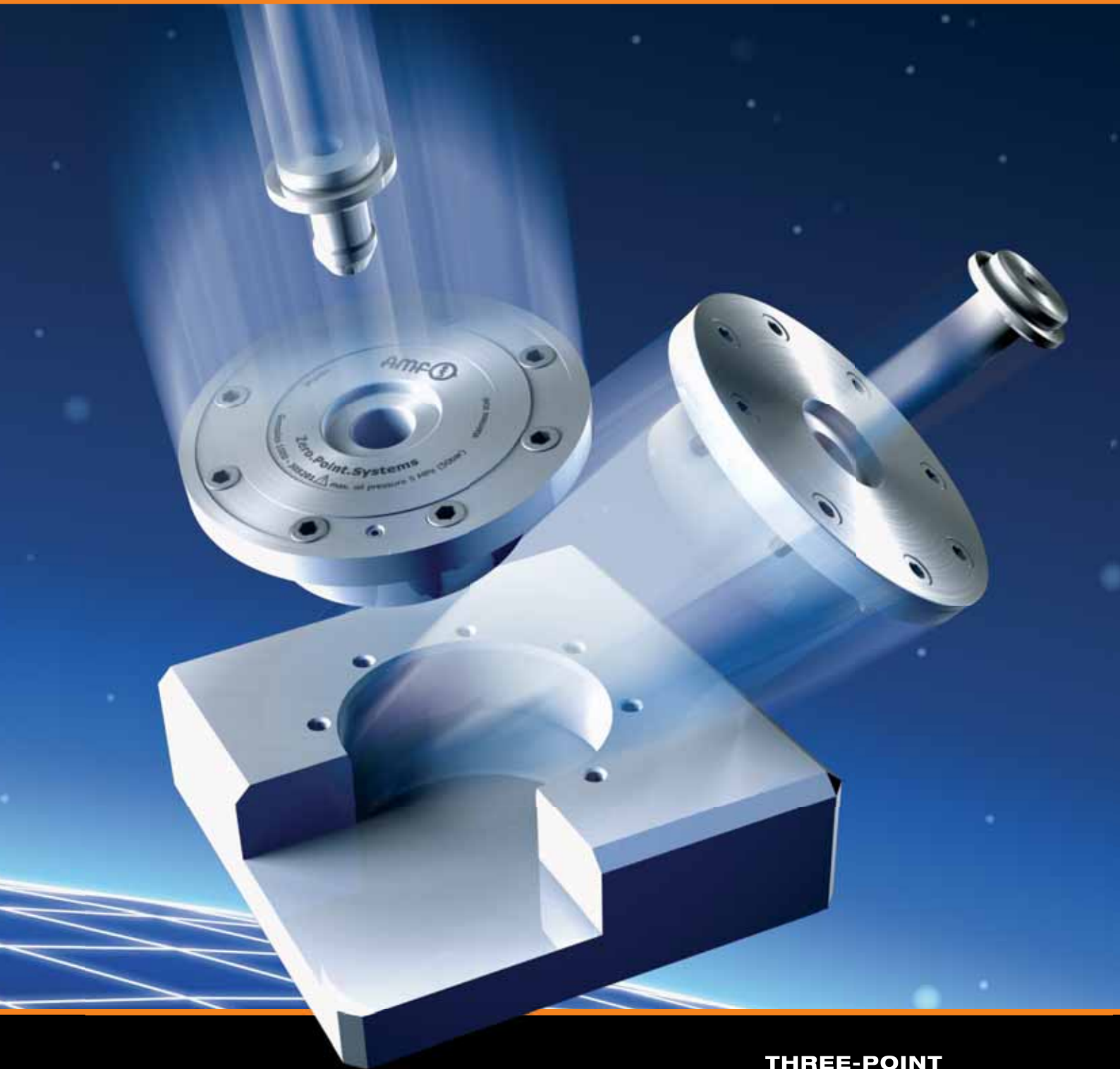

### NO BALL CAGE



The balls lie freely in the ball canal. This freedom of movement enables the balls to continuously re-position themselves.

### SWING-FREE



Swing-free run-in and run-out through the optimal contour of the clamping nipple (only Gonzales modules).

### THREE-POINT PRINCIPLE

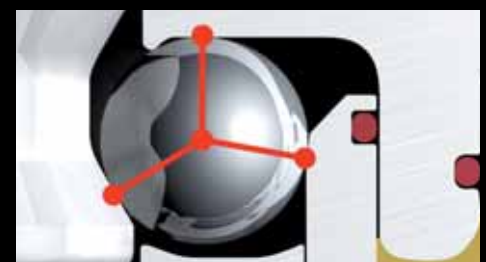

Power transmission by means of the three-point principle! This optimised force distribution prevents shearing load on the balls.

## No. 6370EGRH

### Installation clamping module "Gonzales", round

Hydraulic opening.  
Opening operating pressure: min. 50 bar - max. 60 bar  
Cover and piston hardened.  
Repeatability < 0.005 mm.



STAINLESS STEEL

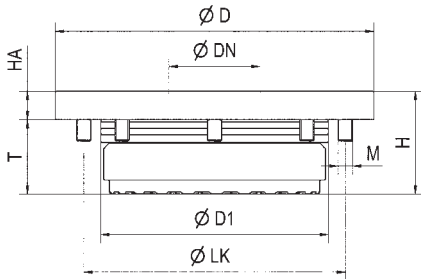

Order no.	Size	Pull-in/locking force up to [kN]	Holding force [kN]	sim. install. dimensions as Speedy	sim. install. dimensions as DockLock	Weight [Kg]
305201	1000	15	25	√	-	2,3
306043	1000	15	25	-	√	2,3
305219	2000	25	55	√	-	3,5

#### Application:

Zero-point clamping system for set-up-time-optimized clamping with cutting and non-cutting processing in all areas, also in the food, pharmaceutical and chemical industry.

#### Note:

Use „Gonzales“ modules exclusively with „Gonzales“ modules in one clamping. When changing systems, observe the following: Unlike Speedy 1000/2000 and DockLock 1000, „Gonzales“ modules require an unclamping pressure of min. 50 bar / max. 60 bar. With recessed installation, observe the cover diameter D 112 mm / 140 mm. The installation clamping module is opened hydraulically (1) and mechanically locked through spring force. Subsequent uncoupling of the pressure lines is possible at all times (module is tensioned pressure-free).  
Clamping module has one connection: 1x hyd. opening (1).

#### On request:

- Installation diagrams
- Automation solutions

#### Dimensions

Order no.	Size	dia. D	dia. DN	dia. D1	H	HA	dia. LK	M	T
305201	1000	112	32	80	36	10	92	8 x M5	26
306043	1000	112	32	80	36	10	91	10 x M5	26
305219	2000	140	47	110	36	10	122	8 x M5	26

## No. 6370EGQH

### Installation clamping module "Gonzales", square

Hydraulic opening.  
Opening operating pressure: min. 50 bar - max. 60 bar  
Cover and piston hardened.  
Repeatability < 0.005 mm.



STAINLESS STEEL

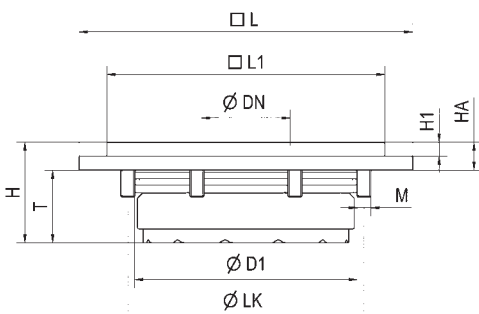

Order no.	Size	Pull-in/locking force up to [kN]	Holding force [kN]	Weight [Kg]
305227	1000	15	25	2,3
305235	2000	25	55	3,5

#### Application:

Zero-point clamping system for set-up-time-optimized clamping with cutting and non-cutting processing in all areas, also in the food, pharmaceutical and chemical industry. A square clamping module prevents the pallet from twisting. The indexing function enables positioning every 90°. Specially suitable for use in turning.

#### Note:

Use „Gonzales“ modules exclusively with „Gonzales“ modules in one clamping. When changing systems, observe the following: Unlike Speedy 1000/2000 and DockLock 1000, „Gonzales“ modules require an unclamping pressure of min. 50 bar / max. 60 bar. With recessed installation, observe dimension L 120 mm / 150 mm. The clamping module is opened hydraulically (1) and mechanically locked through spring force. Subsequent uncoupling of the pressure lines is possible at all times (module is tensioned pressure-free).  
Clamping module has one connection: 1x hyd. opening (1).

#### On request:

- Installation diagrams
- Automation solutions

#### Dimensions

Order no.	Size	dia. DN	dia. D1	H	HA	H1	L	L1	dia. LK	M	T
305227	1000	32	80	36	10	5	120	100	92	M5	26
305235	2000	47	110	36	10	5	150	130	122	M5	26



## No. 6370AGRH

### Surface-mounted clamping module "Gonzales", round

Hydraulic opening.  
Opening operating pressure: min. 50 bar - max. 60 bar  
Cover and piston hardened.  
Repeatability < 0.005 mm.



STAINLESS STEEL

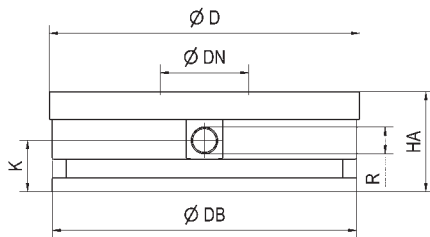

Order no.	Size	Pull-in/locking force up to [kN]	Holding force [kN]	Weight [Kg]
303362	1000	15	25	2,3
303388	2000	25	55	3,5

#### Application:

Zero-point clamping system in combination with clamping flanges (cat. p. 25) for set-up-time-optimized clamping with cutting and non-cutting processing in all areas, also in the food, pharmaceutical and chemical industry.

#### Note:

Use „Gonzales“ modules exclusively with „Gonzales“ modules in one clamping. When changing systems, observe the following: Unlike Speedy 1000/2000 and DockLock 1000, „Gonzales“ modules require an unclamping pressure of min. 50 bar / max. 60 bar. The surface-mounted clamping module is opened hydraulically (1) and mechanically locked through spring force. Subsequent uncoupling of the pressure lines is possible at all times (module is tensioned pressure-free).  
The clamping module has one connection: 1x hyd. opening (1).

#### On request:

- Automation solutions

#### Dimensions

Order no.	Size	dia. D	dia. DB	dia. DN	HA	K	R
303362	1000	112	110	32	40	18,5	G1/8
303388	2000	140	139	47	40	18,5	G1/8

## No. 6370AGQH

### Surface-mounted clamping module "Gonzales", square

Hydraulic opening.  
Opening operating pressure: min. 50 bar - max. 60 bar  
Cover and piston hardened.  
Repeatability < 0.005 mm.



STAINLESS STEEL

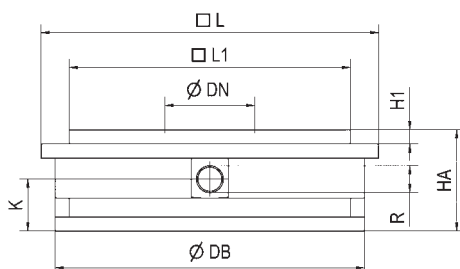

Order no.	Size	Pull-in/locking force up to [kN]	Holding force [kN]	Weight [Kg]
305649	1000	15	25	2,3
305656	2000	25	55	3,5

#### Application:

Zero-point clamping system in combination with clamping flanges (cat. p. 25) for set-up-time-optimized clamping with cutting and non-cutting processing in all areas, also in the food, pharmaceutical and chemical industry.

Clamping flange with Gonzales 2000 integrated onto the housing.

#### Note:

Use „Gonzales“ modules exclusively with „Gonzales“ modules in one clamping. When changing systems, observe the following: Unlike Speedy 1000/2000 and DockLock 1000, „Gonzales“ modules require an unclamping pressure of min. 50 bar / max. 60 bar. The surface-mounted clamping module is opened hydraulically (1) and mechanically locked through spring force. Subsequent uncoupling of the pressure lines is possible at all times (module is tensioned pressure-free).  
The clamping module has one connection: 1x hyd. opening (1).

#### On request:

- Automation solutions

#### Dimensions

Order no.	Size	dia. DB	dia. DN	HA	H1	K	L	L1	R
305649	1000	110	32	40	5	18,5	120	100	G1/8
305656	2000	139	47	40	5	18,5	150	130	G1/8

## No. 6370EURL

### Installation clamping module "Unitool", round

Pneumatic opening.  
 Opening operating pressure: min. 8 bar - max. 12 bar  
 Retensioning operating pressure (turbo): min. 5 bar - max. 6 bar  
 Cover and piston hardened.  
 Repeatability < 0.005 mm.



STAINLESS STEEL

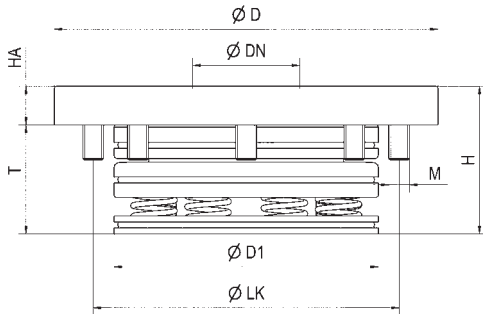

Order no.	Pull-in/locking force up to [kN]	Holding force [kN]	Weight [Kg]
303560	30	55	3,2

#### Application:

Zero-point clamping system for set-up-time-optimized clamping with cutting and non-cutting processing in all areas, also in the food, pharmaceutical and chemical industry.

#### Note:

The installation clamping module has high holding, pull-in and locking forces. This is opened pneumatically (1) and mechanically locked through spring force. To achieve the specified pull-in and locking forces, it must be briefly retensioned pneumatically (turbo) (2). Subsequent uncoupling of the pressure lines is possible at all times (module is tensioned pressure-free). Use of the pneumatic pressure booster (cat. p. 57) is recommended.

The clamping module has two connections:  
 1x pneum. opening (1) / 1x pneum. retensioning (turbo) (2).  
 Use „Unitool“ modules exclusively with „Unitool“ modules in one clamping.

#### On request:

- Installation diagrams
- Automation solutions

#### Dimensions

Order no.	dia. D	dia. DN	dia. D1	H	HA	dia. LK	M	T
303560	148	40	102	57	15	118	M8	42

## No. 6370AURL

### Surface-mounted clamping module "Unitool", round

Pneumatic opening.  
 Opening operating pressure: min. 8 bar - max. 12 bar  
 Retensioning operating pressure (turbo): min. 5 bar - max. 6 bar  
 Cover and piston hardened.  
 Repeatability < 0.005 mm.



STAINLESS STEEL

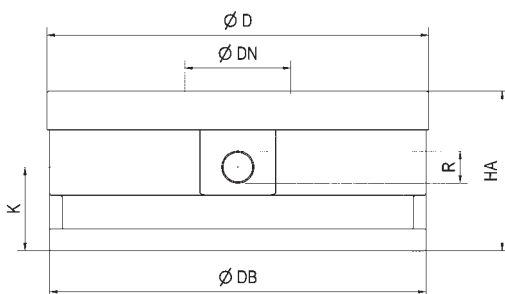

Order no.	Pull-in/locking force up to [kN]	Holding force [kN]	Weight [Kg]
303586	30	55	6,5

#### Application:

Zero-point clamping system in combination with clamping flanges (cat. p. 25) for set-up-time-optimized clamping with cutting and non-cutting processing in all areas, also in the food, pharmaceutical and chemical industry.

#### Note:

The surface-mounted clamping module has high holding, pull-in and locking forces. This is opened pneumatically (1) and mechanically locked through spring force. To achieve the specified pull-in and locking forces, it must be briefly retensioned pneumatically (turbo) (2). Subsequent uncoupling of the pressure lines is possible at all times (module is tensioned pressure-free). Use of the pneumatic pressure booster (cat. p. 57) is recommended.

The clamping module has two connections:  
 1x pneum. opening (1) / 1x pneum. retensioning (turbo) (2).  
 Use „Unitool“ modules exclusively with „Unitool“ modules in one clamping.

#### On request:

- Automation solutions

#### Dimensions

Order no.	dia. D	dia. DB	dia. DN	HA	K	R
303586	148	146	40	62	32,5	G1/4

Subject to technical alterations.

## No. 6370ZNG-10

### Clamping nipple „Gonzales 1000“

Hardened.

Clamping nipples can also be used in the modules Speedy 1000 and DockLock 1000.



Order no.	Size	dia. DN	dia. D1	H	M	T	Weight [g]
303404	1000	32	25	34,0	M8	4,8	70
303420	1000	32	25	34,0	M8	4,8	70
303446	1000	32	25	34,0	M8	4,8	70
303461	1000	32	-	29,2	M8	12,0	55

#### Design:

Order no. 303404: Zero point nipple

Order no. 303420: Slit nipple

Order no. 303446: Undersized nipple

Order no. 303461: Protection nipple

#### Note:

Tightening torque of the clamping nipple max. 20 Nm.  
Min. screw grade 8.8.

#### Dimensions for the nipple mounting:

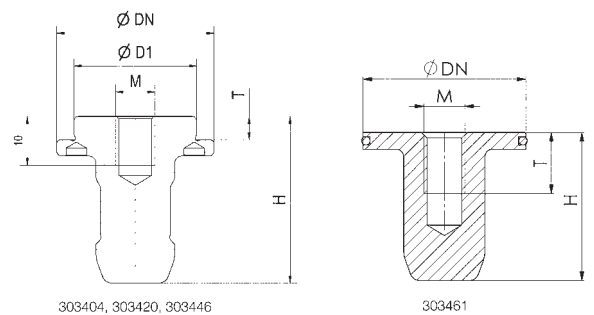
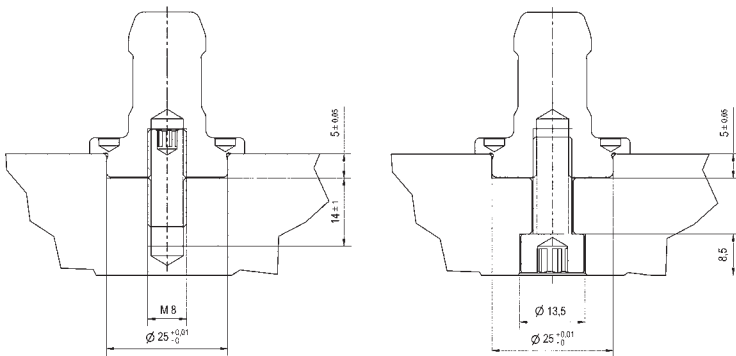

## No. 6370ZNGH-10

### Clamping nipple „Gonzales 1000“

with high collar, hardened.

Clamping nipples can also be used in the modules Speedy 1000 and DockLock 1000.



Order no.	Size	dia. DN	dia. D1	H	M	T	Weight [g]
305128	1000	32	25	49	M8	19,8	125
305144	1000	32	25	49	M8	19,8	125
305169	1000	32	25	49	M8	19,8	125
303461	1000	32	-	29,2	M8	12,0	55

#### Design:

Order no. 305128: Zero point nipple

Order no. 305144: Slit nipple

Order no. 305169: Undersized nipple

Order no. 303461: Protection nipple

#### Note:

Tightening torque of the clamping nipple max. 20 Nm.  
Min. screw grade 8.8.

#### Dimensions for the nipple mounting:

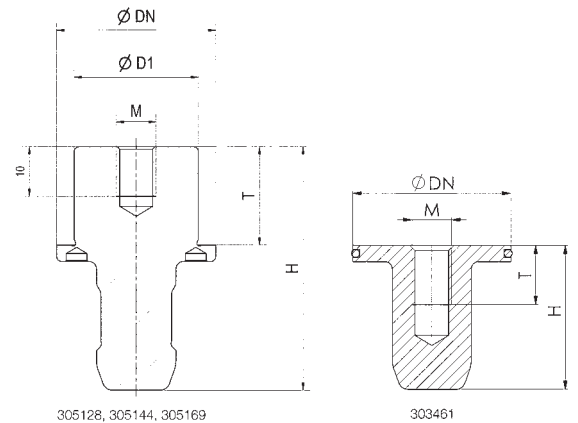
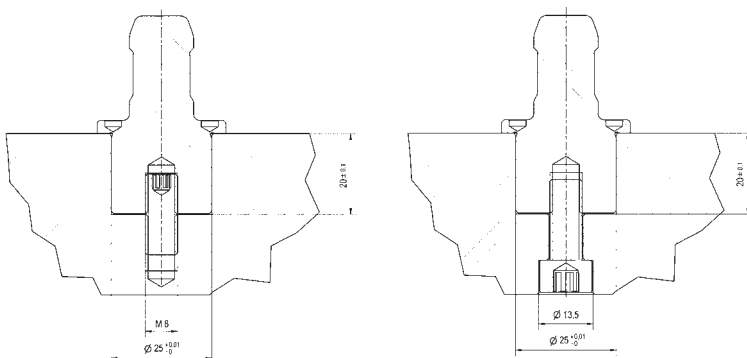

## No. 6370ZNG-20

### Clamping nipple „Gonzales 2000“

Hardened.  
Clamping nipples can also be used in Speedy 2000.



Order no.	Size	dia. DN	dia. D1	dia. D2	H	M	T	Weight [g]
303412	2000	47	25	10,8	34,0	M12	4,8	170
303438	2000	47	25	10,8	34,0	M12	4,8	170
303453	2000	47	25	10,8	34,0	M12	4,8	170
303479	2000	47	-	-	29,2	M 8	12,0	180

#### Design:

Order no. 303412: Zero point nipple  
Order no. 303438: Slit nipple  
Order no. 303453: Undersized nipple  
Order no. 303479: Protection nipple

#### Note:

Tightening torque of the clamping nipple max. 20 Nm.  
Min. screw grade 8.8.

### Dimensions for the nipple mounting:

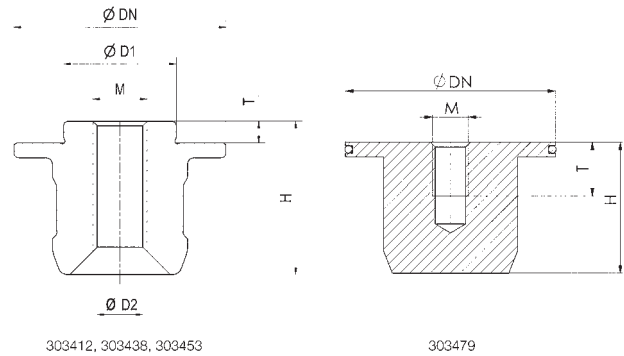
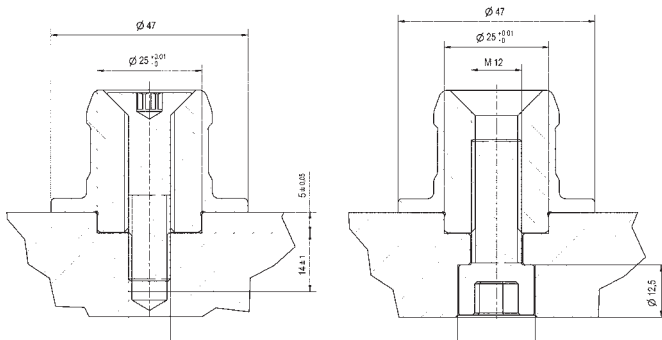

## No. 6370ZNSG

### Nipple key „Gonzales“

for clamping nipple no. 6370ZNG/ZNGH „Gonzales 1000“.



Order no.	SW [mm]	Weight [g]
306001	22	80

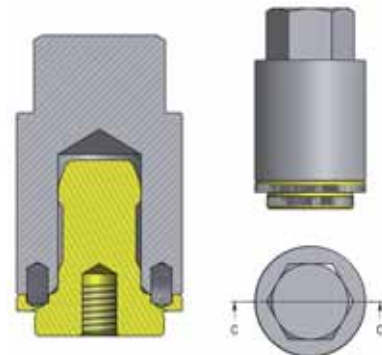

## No. 6370ZNU

### Clamping nipple „Unitool“

Hardened.

Clamping nipples can also be used in the Unilock system (Ø 40 mm).



Order no.	dia. DN	dia. D1	dia. D2	H	M	T	Weight [g]
304352	40	25	10	40,0	M12	4,8	230
304592	40	25	10	40,0	M12	4,8	230
304618	40	25	10	40,0	M12	4,8	230
304634	40	-	-	34,7	M 8	12,0	220

#### Design:

Order no. 304352: Zero point nipple

Order no. 304592: Slit nipple

Order no. 304618: Undersized nipple

Order no. 304634: Protection nipple

#### Dimensions for the nipple mounting:

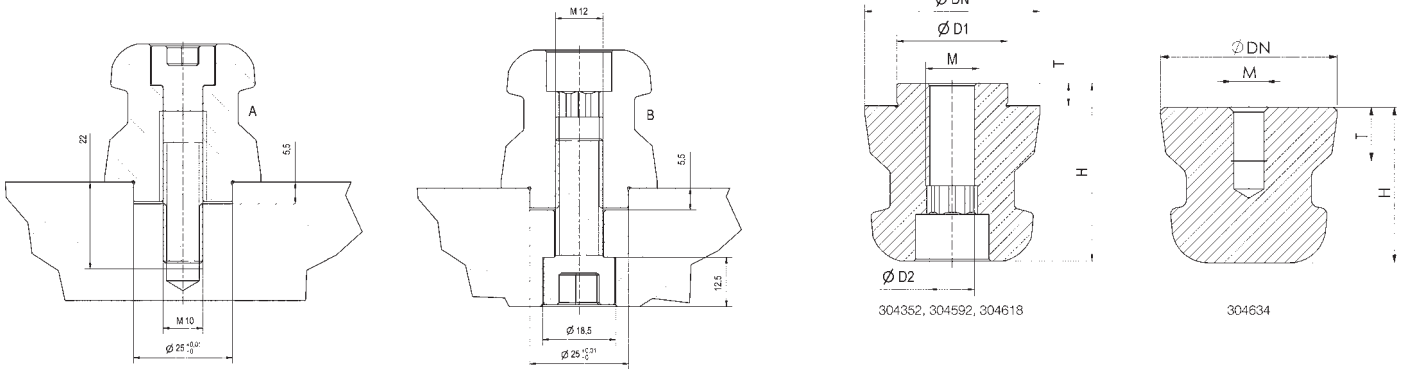

Subject to technical alterations.

**... BY ITEM NO.**

Article no.	Cat. p.	Article no.	Cat. p.	Article no.	Cat. p.	Article no.	Cat. p.	Article no.	Cat. p.
No. 6100H-20-05	34	No. 6370AGQH	65	No. 6370P6	45	No. 6370ZN-20	46	No. 6370ZVL-004	57
No. 6100H-20-06	34	No. 6370AGRH	65	No. 6370S2-001	42	No. 6370ZN-40	46	No. 6370ZVL-005	57
No. 6101L	36	No. 6370AURL	66	No. 6370S2-002	42	No. 6370ZNG-10	67	No. 6370ZVL-006	57
No. 6102H	38	No. 6370EAQH	16	No. 6370S4-001	43	No. 6370ZNG-20	68	No. 6370ZZ	52
No. 6102ZN	52	No. 6370EAQL	16	No. 6370S6-001	43	No. 6370ZNGH-10	67	No. 6904-20	56
No. 6151H	19	No. 6370EARH	14, 15	No. 6370ZA	51	No. 6370ZNI	49	No. 6984-30	53
No. 6151L	19	No. 6370EARH MV	35	No. 6370ZB	25	No. 6370ZNS-001	48	No. 6985R	58
No. 6201H	17	No. 6370EARL	14, 15	No. 6370ZD	56	No. 6370ZNS-002	48	No. 6988	59
No. 6201ZN	50	No. 6370EGQH	64	No. 6370ZF	60	No. 6370ZNSA	51	No. 6989N	54
No. 6201ZS	50	No. 6370EGRH	64	No. 6370ZMM	55	No. 6370ZNSG	68	No. 6990	59
No. 6202HS4	41	No. 6370EURL	66	No. 6370ZMMG	54	No. 6370ZNSN	49	No. 6990MK/SK	59
No. 6370AAQH	24	No. 6370HARH	26	No. 6370ZMNG	55	No. 6370ZNSSN	49		
No. 6370AAQL	24	No. 6370KARH	29	No. 6370ZMSH	52	No. 6370ZNU	69		
No. 6370AARH	22, 23	No. 6370P2	44	No. 6370ZN-5	46	No. 6370ZR	58		
No. 6370AARL	22, 23	No. 6370P4	44	No. 6370ZN-10	46	No. 6370ZVL	60		

**... BY ORDER NO.**

Order no.	Cat. p.	Order no.	Cat. p.	Order no.	Cat. p.	Order no.	Cat. p.	Order no.	Cat. p.
164988	54	303412	68	305367	15	306274	26	425041	44
<b>302828</b>	23	303420	67	305375	15	<b>320960</b>	58	<b>426494</b>	60
302836	23	303438	68	305383	60	320986	58	<b>426502</b>	52
302844	23	303446	67	305391	60	<b>321000</b>	58	426528	52
302851	23	303453	68	<b>305409</b>	58	321026	58	426544	52
302869	23	303461	67	305417	58	321042	58	426569	56
302877	23	303479	68	305425	58	321067	58	<b>426700</b>	44
302885	23	303487	23	<b>305649</b>	65	<b>325217</b>	53	426726	42
302893	23	<b>303503</b>	29	305656	65	<b>340034</b>	49	426734	43
<b>302984</b>	15	303529	23	305664	24	340059	49	426742	43
302992	15	303545	23	305672	24	<b>420919</b>	38	426759	43
<b>303008</b>	15	303560	66	305680	24	<b>421396</b>	57	426767	44
303016	15	303578	48	305698	24	<b>421602</b>	41	426775	45
303024	15	303586	66	<b>305706</b>	24	<b>422345</b>	51	426783	44
303032	15	<b>303602</b>	15	305714	24	422360	51	426791	45
303040	15	303610	46	305722	24	422386	51	<b>426809</b>	44
303057	15	303628	15	305730	24	<b>422402</b>	51	426815	25
303065	26	303636	46	305748	24	422428	51	426817	45
303073	26	<b>304352</b>	69	305755	24	422444	51	426833	25
<b>303107</b>	26	<b>304519</b>	46	305763	24	<b>423947</b>	19	426841	25
303115	26	304535	46	305771	24	423962	19	426866	52
303149	46	304592	69	<b>305912</b>	49	423970	50	426882	49
303156	46	<b>304618</b>	69	305938	49	423988	19	<b>426908</b>	49
303164	46	304634	69	305953	14	423996	50	<b>427021</b>	49
303172	46	<b>305128</b>	67	305979	14	<b>424002</b>	54	427047	49
303172	50	305144	67	<b>306001</b>	68	424010	50	427062	49
303180	46	305169	67	306019	46	424036	50	427088	57
303198	46	305193	23	306027	35	424069	19	<b>427104</b>	57
<b>303206</b>	46	<b>305201</b>	64	306035	46	424085	19	427146	34
303214	46	305219	64	306043	64	<b>424101</b>	19	427161	34
303222	48	305227	64	306050	46	424119	43	<b>63206</b>	58
303230	48	305235	64	306076	46	424127	19	63214	58
303248	48	305243	16	306084	17	424143	19	63222	58
303255	48	305250	16	306092	48	424168	19	63230	58
303263	42	305268	16	<b>306159</b>	22	424184	54	63248	58
303271	42	305276	16	306167	52	424192	36	<b>65508</b>	59
303289	42	305284	16	306175	22	<b>424200</b>	55	65524	59
303297	42	305292	16	306183	52	424226	55	<b>68817</b>	59
<b>303321</b>	43	<b>305300</b>	16	<b>306209</b>	52	424242	55	68825	59
303339	43	305318	16	306217	26	424267	55	<b>69021</b>	59
303354	56	305326	16	306225	52	<b>424556</b>	52	69039	59
303362	65	305334	16	306233	26	424564	36		
303388	65	305342	16	306241	52	424580	36		
<b>303404</b>	67	305359	16	306258	26	<b>425033</b>	44		

These conditions of sale apply to business conducted with companies, legal entities in the public sector, and legal entities with special budget in the public sector. Our deliveries and services are carried out exclusively on the basis of the conditions stated below. Deviating purchasing conditions of the buyer will not become part of the contract, not even through acceptance of the order, unless we have expressly accepted them.

## 1. Offer and entering into a contract

The basis of our delivery contracts is the latest edition of our catalogue. Orders are not considered as accepted until they have been confirmed by us in writing. When goods are supplied from stock and, for organisational reasons, you receive no separate confirmation, the invoice has the additional function of confirming the order. Details of dimensions and weights, and illustrations, drawings and data are not binding and may be changed by us at any time. Deviations cannot be excluded.

## 2. Prices

Prices are quoted in EUR ex-works excluding turnover tax, packing, freight, carriage, and insurance. Unless otherwise agreed, our list prices on the day of delivery apply. In order to cover our costs, orders under EUR 50.– net value are subject to a small order surcharge of EUR 10.–.

## 3. Delivery

Delivery delays are quoted to the best of our knowledge but without guarantee. Agreed delivery delays begin on the day we accept the order and refer to the completion of the goods in our works.

## 4. Transfer of risk

Risks are transferred to you when the goods are passed to a specific person, company, or organisation that is charged with the execution of carriage of the goods. This applies also to partial deliveries and when we have accepted the costs of carriage, delivery or erection. The risks are also transferred to you when you have defaulted on acceptance.

## 5. Dispatch

Goods are supplied ex-works. Dispatch is at your cost and risk. Scheduled, FOB, and CIF deliveries are also at your risk. In the absence of specific instructions concerning dispatch, we will arrange same as we think fit, but without accepting any responsibility for choosing the cheapest or most suitable method of dispatch. We make a handling charge of EUR 5.– if goods are sent at your request to a third party. You accept that your order can be supplied in partial deliveries insofar as this is reasonable.

## 6. Reservation of proprietary rights

Goods delivered remain our property until payment of all claims has been received in full or until redemption of cheques given in payment. The cancellation of individual positions in an open invoice and the drawing of a balance and its acceptance do not affect proprietary rights. You have the right to dispose of the goods as a normal commercial transaction, but you are forbidden to pawn, mortgage, or transfer ownership of them in settlement of a debt or debts. You surrender to us herewith your right to payment for goods for which we reserve our proprietary rights. You have the right to collect these payments as long as you meet your obligations to us. If we request it, you are obliged to name the third party and we have the right to publish this information and the transfer of rights.

## 7. Cancellation rights due to late payment or insolvency

If you do not pay for the goods by the time payment is due, and if you have not paid after expiry of a reasonable time limit set by us, we have the right to withdraw from the contract and demand the return of goods already supplied. Rights under § 323 BGB (BGB = German civil law code) remain otherwise unaffected. Application for the opening of insolvency proceedings gives us the right to withdraw from the contract and demand the immediate return of goods supplied before the bankruptcy court orders protective measures.

## 8. Packaging

Packages comply with the German packaging regulations (WO). Disposable packaging is charged at cost. The packaging is not returnable.

## 9. Tooling costs

In the absence of any agreement to the contrary, tooling made for the execution of an order remains our property in all cases. This applies even if we have made a charge for a proportion of the tooling costs.

## 10. Payment

Our invoices are payable net within 30 days of the date of the invoice, or with 2% discount if paid within 10 days. Invoices below EUR 50.– are payable immediately without discount. Our credit notes and your charges on us reduce the amount subject to discount. Late payment entitles us to interest at the rate the bank charges us for a current account overdraft but at least 8 percent above the current base rate of the European Central Bank. If payment is overdue, we are entitled, after giving you notice in writing, to cease fulfilling our obligations under the contract until payment is received.

## 11. Offsetting exclusion

You can only offset payments with legally-established or unopposed counter claims.

## 12. Guarantee

If you come to an agreement with us on properties of the goods, we include this agreement in our technical specifications. If we have to supply to your drawings, specifications, samples, etc., you accept the risk associated with suitability for the intended purpose. The point in time at which risk is transferred is decisive for the contractual condition of the goods. The deterioration of parts subject to wear in the course of normal use does not constitute a defect. If the goods supplied are defective, we will – at our choice and within a reasonable time limit set by you – supply a replacement or repair the goods. If such repair or replacement is not satisfactory, you have the right to reduce the price or withdraw from the contract. Any further guarantee claims are excluded. Recognisable defects must be notified at the latest within 10 days of receipt and defects that are not recognisable must be notified as soon as they are discovered. The guarantee period is 24 months and starts with dispatch of the goods from our works.

## 13. Hindered or impossible performance

If we are prevented from meeting our obligation by some unforeseeable event (e.g. disruption of our plant, or delay in the delivery of important raw materials), which, in spite of taking all reasonable care appropriate to the circumstances of the case, we have been unable to avert, and it has become impossible to execute the delivery or service punctually, the delivery delay will be extended to an appropriate extent.

## 14. Liability

Except in the case of injury to life or limb, or damage to health caused by our breach of duty, we are only liable in the event of intent or culpable negligence on our part.

## 15. Customer specials

Orders for customer specials must be in writing and include binding details of execution, quantities etc. For technical reasons we reserve the right to supply 10% more or less than the quantity specified. If technical changes or cancellation are required, the costs incurred will be charged to the customer.

## 16. Deliveries of samples and return of goods

Samples will be charged. When goods have been sent for testing or as samples, we will credit you with the additional price against subsequent orders, as long as the net contract value is at least EUR 125.–. The return of goods is only possible with prior agreement. Customer specials may not be returned. For goods returned for reasons outside our responsibility (e.g. wrongly ordered), we charge 10% of the value of the goods but at least EUR 7.50, to cover administration costs.

## 17. Place of fulfilment, court of jurisdiction

The place of fulfilment for all obligations arising from this contract is D-70707 Fellbach. The court of jurisdiction for any legal dispute arising from this contract is D-71332 Waiblingen. (All disputes that arise from this contract or about its validity will be decided by a court of arbitration according to the Arbitration Rules of the German Committee for Arbitration Courts/Settlement and Arbitration Procedure of the International Chamber of Commerce. Such decisions will be final and normal legal procedures are excluded.) German law applies (BGB and HGB = civil and commercial codes). The application of UN purchasing law (CISG) is excluded.

## 18. Validity clause

If individual conditions should be found to be not legally valid, the remaining conditions continue to apply. The invalid conditions will be replaced by conditions which fulfil as closely as possible the commercial intent of the contract with reasonable consideration of the interests of both parties. With the publication of these Conditions for Sales, Deliveries and Payment, all previous versions become invalid. This does not apply to contracts agreed before publication.

...just copy  
and mail or fax

ANDREAS MAIER  
GmbH & Co. KG  
Schloss- und  
Werkzeugfabrik  
Postfach 1760

70707 FELLBACH

## REQUEST FOR CATALOGUES:

- |   |   |
|---|---|
| <input type="checkbox"/> Locks for doors and gates              | <input type="checkbox"/> Clamping and fixture systems                         |
| <input type="checkbox"/> Hand tools                             | <input type="checkbox"/> Magnetic clamping technology                         |
| <input type="checkbox"/> Toggle clamps,<br>manual and pneumatic | <input type="checkbox"/> Zero-Point Systems                                   |
| <input type="checkbox"/> Mechanical clamping<br>elements        | <input type="checkbox"/> Clamping and fixture system<br>for automated welding |
| <input type="checkbox"/> Hydraulic clamping systems             | <input type="checkbox"/> Positioning system<br>for laser marking              |

Company/Address (please don't forget your phone no.)

responsible



TOGGLE CLAMPS,  
MANUAL AND PNEUMATIC



HAND TOOLS



MAGNETIC CLAMPING  
TECHNOLOGY



HYDRAULIC CLAMPING  
SYSTEMS



MECHANICAL CLAMPING  
ELEMENTS



ZERO-POINT-SYSTEMS



CLAMPING AND FIXTURE SYSTEM  
FOR AUTOMATED WELDING



LOCKS FOR DOORS  
AND GATES



**CLAMPING. SCREWING. LOCKING.**

**ANDREAS MAIER GmbH & Co. KG**

Waiblinger Straße 116 · D-70734 Fellbach  
Postfach 1760 · D-70707 Fellbach  
Phone: +49 711 5766-0  
Fax: +49 711 575725  
E-Mail: amf@amf.de · Mobile: amf.mobi  
Internet: www.amf.de

**Sales**

Phone: +49 711 5766-112  
Fax: +49 711 575725  
E-Mail: export@amf.de

**Catalogue order no. 189308 · € 2,40**