

Roll Tools

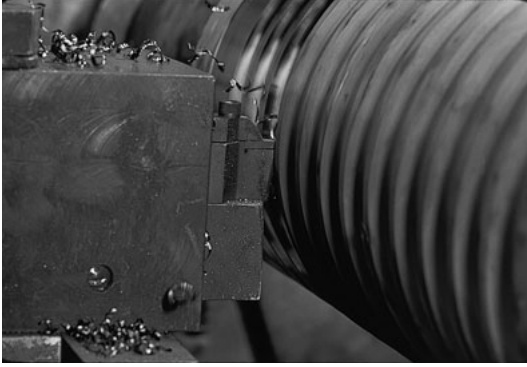



NTK offers various types of ceramic materials and CBN tools, including the whisker-based WA1, in order to meet mill rolls machining requirements. These materials and tools are intended primarily for round inserts. The user can therefore select the appropriate product according to cutting operation.

Features of Grade

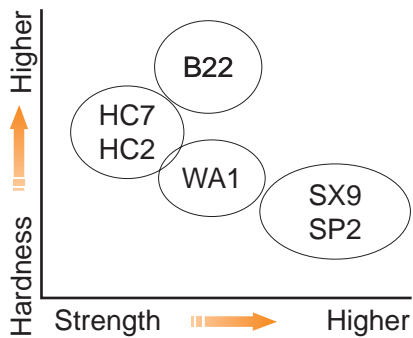

NTK Grade for each Roll Material

Grade	Ceramics			
	CBN B22	Alumina HC7·HC2	Whisker WA1	Silicon-nitride SX9·SP2
Mill Roll				
Forged (High-speed steel)	○	◎	○	
Cast steel	○	◎	○	
Cast iron (Ductile)	○	◎	○	◎

Recommended cutting condition

Insert Grade	Dry	Cutting speed (m/min)					Feed (mm/rev)							
		100	200	300	400	500	0.1	0.2	0.3	0.4	0.5	0.6		
HSS	●	●	●	●	●	●	●	●	●	●	●	●	●	●
	○	○	○	○	○	○	○	○	○	○	○	○	○	○
	○	○	○	○	○	○	○	○	○	○	○	○	○	○
Cast steel	●	●	●	●	●	●	●	●	●	●	●	●	●	●
	○	○	○	○	○	○	○	○	○	○	○	○	○	○
	○	○	○	○	○	○	○	○	○	○	○	○	○	○
Cast Iron Ductile	●	●	●	●	●	●	●	●	●	●	●	●	●	●
	○	○	○	○	○	○	○	○	○	○	○	○	○	○
	○	○	○	○	○	○	○	○	○	○	○	○	○	○
	○	○	○	○	○	○	○	○	○	○	○	○	○	○

Mill Roll Machining Holders

CRDCN

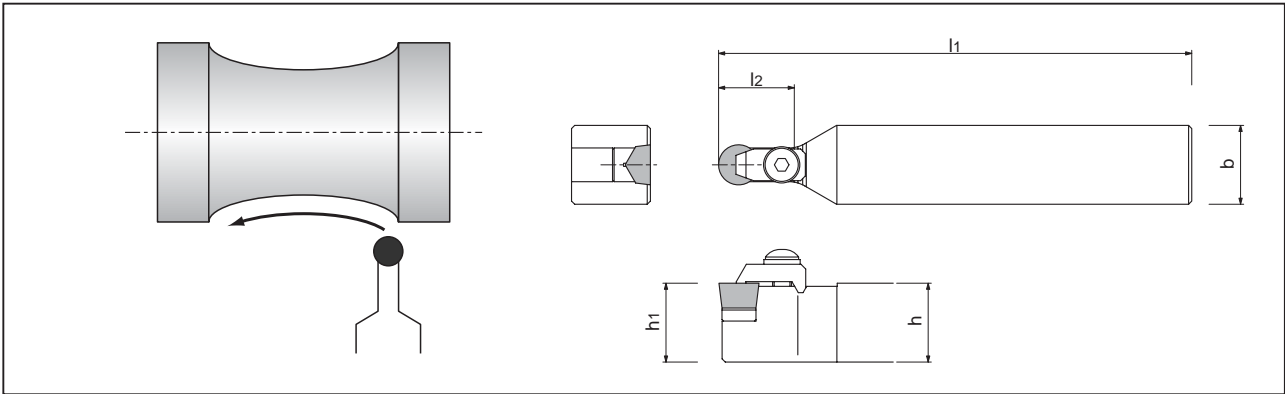

Holder	Stock	Dimensions (mm)					Insert		
		l1	l2	b	h	h1			
CRDCN	2525M06	●	150	20	25	25	25	RCGX 0608	RCGN 0607
	2525M09	●	150	20	25	25	25	RCGX 0908	RCGN 0907
	2525M12	●	150	25	25	25	25	RCGX 1208	RCGN 1207
	3225P06	●	170	20	25	32	32	RCGX 0608	RCGN 0607
	3225P09	●	170	20	25	32	32	RCGX 0908	RCGN 0907
	3225P12	●	170	25	25	32	32	RCGX 1208	RCGN 1207
	3232P15	●	170	30	32	32	32	RCGX 1510	
	3232P19	●	170	42	32	32	32	RCGX 1910	
3232P25	●	170	42	32	32	32	RCGX 2512		

● Insert

Shape	Insert	Dimensions (mm)			Stocked tem		
		d	s	θ	HC2	HC7	WA1
	RCGX 0608 PN	6.35	7.86	120°	●		●
	RCGX 0908 PN	9.525	7.86		●		●
	RCGX 1208 PN	12.70	7.86		●	●	●
	RCGX 1510 PN	15.875	9.86		●	●	
	RCGX 1910 PN	19.05	9.86		●	●	●
	RCGX 2512 PN	25.4	11.91		●		

To use RCGN insert, please change shim-seat as follows.
PN : Double T-land with R-horning

Shape	Insert	d	s	Shim sheet
	RCGN 060700	6.35	7.94	HARCGN 0607-15
	RCGN 090700	9.525		HARCGN 0907-15
	RCGN 120400	12.70		HARCGN 1204-15
	RCGN 120700	15.875		HARCGN 1207-15

● Parts

Parts	Clamp	Shim	Clamping screw	Spring pin	Washer	Wrench
Toolholder						
CRDCN3225P06 / 2525M06	HC35KR-4099	HARCGX06	BS0520		WS-5	LW-3
CRDCN3225P09 / 2525M09	HC35KR-6075	HARCGX0908V	BS0625	2X8AW	WS-6	LW-4
CRDCN3225P12 / 2525M12	HC35KR-6076	HARCGX1208V	BS0625	2.5X8AW	WS-6	LW-4
CRDCN3232P15	CC08M	HARCGX1510V	BS0835W	2.5X8AW	SR08	LW-4
CRDCN3232P19	CC08M	HARCGX1910V	BS0835W	2.5X8AW	SR08	LW-4
CRDCN3232P25	AMS-10	HARCGX2512V	AOB-10S	2.5X8AW		LW-6

Mill Roll Machining Holders

HRCD

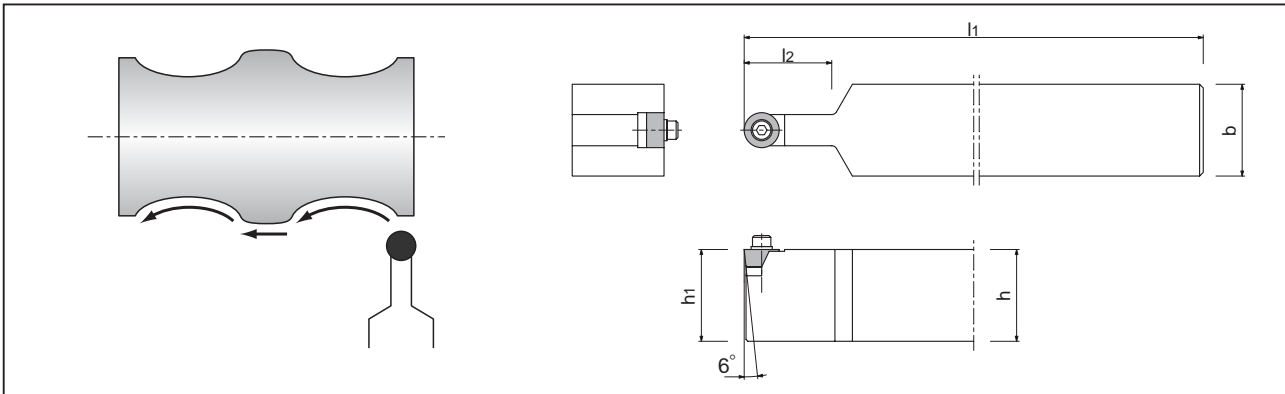



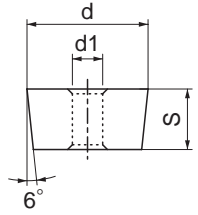

Toolholder	Stock	Dimensions (mm)					Insert
		h	b	l 1	h1	l 2	
HRCD- -22	●	50	50	300	50	30	 CDH 22 CDH 33 CDH 42 CDH 43 CDH 53
- 33	●						
- 42							
- 43							
- 53							

● Insert

Shape	Insert	Dimensions (mm)			Grade	
		d	s	d1	HC2	HC7
 	CDH 22 PN	12.70	6.35	3.18	●	
	CDH 33 PN	19.50	9.52	6.35	●	●
	CDH 42 PN	25.40	12.70	6.75	●	
	CDH 43 PN				19.05	
	CDH 53 PN	31.75	19.05	9.92	●	

PN : Double T-land with R-horning

● Parts

Parts	Cap screw	Washer	Shim	Wrench
   				
HRCD - 22	CS0316	W120	HACDH22	LW-2.5
- 33	CS0625	W110	HACDH33	LW-5
- 42	1/4-20UNC × 11/4	W106	HACDH42	LWU-4
- 43	1/4-20UNC × 11/2	W106	HACDH43	
- 53	3/8-16UNC × 11/2	W107	HACDH53	LWU-5

CRXC

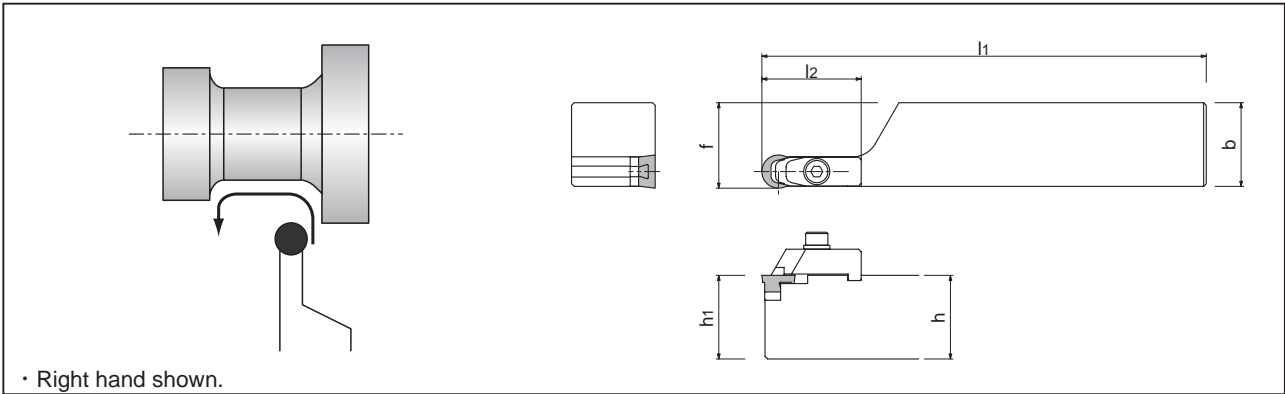





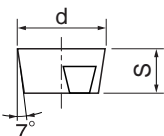

• Right hand shown.

Toolholder	Stock		Dimensions (mm)						Insert	
	R	L	h	b	l1	h1	f	l2		
CRXC ^{R/L} 3232P09Y	○		32	32	170	32	32.7	28		RCGY090603
3232P12Y	○		32	32	170	32	32.7	28		RCGY120603

● Insert

Shape	Insert	Dimensions (mm)		Stocked item		
		d	S	HC2	HC7	WA1
 	RCGY 090603 TNB (T00525)	9.525	6.35			○
	120603 TNB (T00525)	12.70	6.35			○

● Parts

Parts	Clamp	Shim	Clamping screw	Retaining screw	Washer	Spring	Wrench
	Toolholder						
CRXC ^{R/L} 3232P09Y	CRN4	HAR09Y	CS0425	M2 × 8	WS-4	ASGL4	LW-3
3232P12Y	CRN5	HAR12Y	CS0525	M3 × 8	WS-5	ASGL5	LW-4

Mill Roll Machining Inserts

RBGX-S

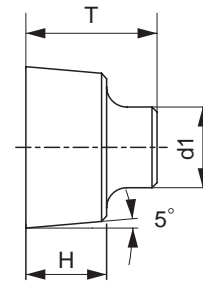
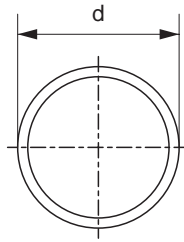

Insert	Dimensions (mm)				Grade		
	d	d1	T	H	HC2	WA1	B22
RBGX 16S PN2 16S SN2 16S 20S PN 20S S 20S 26S PN 26S SN3	16	8	8	13	○		
						○	
	20	10	10	15	○		○
							○
	26	14	10	15	○		
						○	

LNM

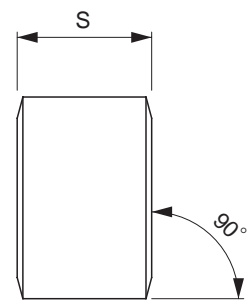
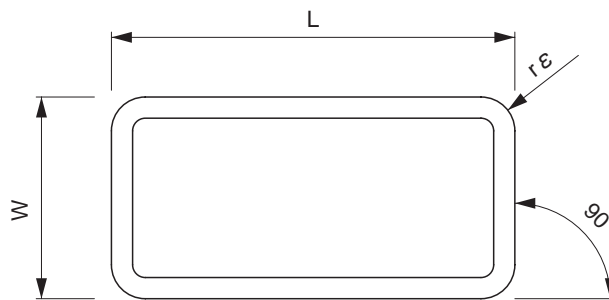

Insert	Dimensions (mm)				Grade		
	W	L	S	rε	HC2	HC7	SX9
LNM 4454 PN 5464 PN 6688 PN 6688 SNX6	12.7	25.40		1.6			
	15.875	25.40	9.525	1.6			
	19.05	38.10	12.70	3.2	●		●
	19.05	38.10	12.70	3.2		●	

Before ordering the parts marked "○" above, please contact NTK for the delivery deadline.
 PN : Double T-land with R-horn SN : T-land with R-horn

● Types, applications, and features of rolls

Mill Rolls Material	Applications	Features
Forged rolls <ul style="list-style-type: none"> ● Cr-Mo-based ● High-speed-steel-based ● Carbon-based 	Bloom-milling at heavy rolling load. Work rolls for rough cold rolling, and rolls for reinforcement.	Strong and relatively high in heat resistance.
Cast iron rolls <ul style="list-style-type: none"> ● Carbon-based 	Semi-rolling or finishing that requires a very heavy load	More wear-resistant than steel in between ordinary steel and cast-iron-based steel.
Cast iron rolls <ul style="list-style-type: none"> ● Amadite roll for deep caliber ● Chilled roll for boards and wire steel process ● Grain roll for steel finishing process boards (Resistant to thermal crack) ● Ductile roll for boards, profile steel, and bar wire steel process (Rolls for roughing and finishing use) ● Special cast iron roll 	Wide range of applications from bloom-milling and semi-rolling to finishing.	Suitable for the applications that require heat resistance and strength. Suitable for the applications that require wear resistance.