



Made in Germany



Gauge Blocks and Accessories

**Wear resistant Special Steel
Ceramic
Carbide**



**Calibration Center of the
German Calibration Service**
for length up to 1000 mm

DKD

accredited by

Physikalisch - Technische Bundesanstalt - PTB



Calibration-Service
Calibration of used gauge blocks
and gauges

In accordance with DIN/ISO 9000 – 9004, traceable
to National Standards via our own **DKD**-laboratory



KOLB & BAUMANN GMBH & CO. KG
PRECISION MEASURING TOOLS MAKERS
DE-63741 ASCHAFFENBURG · DAIMLERSTR. 24
GERMANY

PHONE +49 (6021) 3463-0 · FAX +49 (6021) 3463-40
Internet <http://www.koba.de> · e-mail: messzeuge@koba.de

Catalogue No. 1000/E/01/2007

Dear Customer,

Today you have the documents of Kolb & Baumann in your hands.

We are glad that you are interested in our products.

The foundations of KOBA were laid more than 60 years ago and at the beginning the manufacture of gauge blocks was the major line. At that time gauge blocks were made out of steel. Later carbide and ceramic were added. Furthermore we manufacture accessories in order to extend the application of our gauge blocks. In order to complete the product range we started the manufacture of gauges.

It was in 1979 when Kolb & Baumann got accredited by the PTB as the 8th DKD-calibration laboratory in Germany. This accreditation comprises the measured value "length" up to 1000 mm. Today out of the three laboratories in Germany who are accredited up to a length of 1000 mm KOBA is one of them. Besides, KOBA is an accredited DKD-laboratory for gauges and other measuring instruments.

KOBA supplies world-wide into more than 40 countries and is also supplier for gauge blocks and calibration masters to various National Physical Laboratories.

Our world-wide customers trust in KOBA-gauge blocks and gauges as a high-grade German quality product.

Being a German family-based company we will do all efforts to keep the confidence in our products. This is our tradition and obligation for the future.

Your KOBA-management



Dipl.-Ing. Adolf Baumann



Dipl.-Bw. Alexander Baumann

Contents

Gauge Block	Page
Introduction	4
Ceramic Gauge Blocks	5
Accuracy	6
Material	7
Single Gauge Blocks	7
Sets of Gauge Blocks	8 + 9
Supplementary Sets	10, 11 + 12
Guidelines for calibrating Gauge Block Comparators	13
German Calibration Service - DKD	14 + 15
KOBA-Calibration Service	16
Maintenance of Gauge Blocks	17
Gauge Block Accessories	
Examples	18
Gauge Block Holders	19
Measuring Jaws	19
Other Component Parts	20
Sets of Accessories	21
Sets of Accessories for internal gauge sets	22
Your Contact Persons at KOBA	23
Manufacturing programme	24

Subject to modifications of design, dimensions, combinations and weights.

Reprint of test and illustration, also as excerpts, only with our authorization.

The data of the Standard Sheets are given herein by the courtesy of the German Standardization Committee. The latest edition is available in Standard Sheet Size A 4 from Messrs. Beuth-Vertriebs-GmbH, 10787 Berlin and Cologne.

Edition 2007
Printed in Germany – Imprimé en Allemagne
Rückziegel Druck GmbH, Stiftsgasse 17, DE-63739 Aschaffenburg



**HARDNESS
WEAR
RESISTANCE
STABILITY
SERVICE**



Gauge Blocks

are a high quality product, our exacting standards are backed by more than 60 years experience and research, resulting in the careful selection of the purest steel which must fulfill our high standard demanded, especially with regard to

stability, wear resistance, uniform co-efficient of expansion. The ageing to eliminate internal stresses and stabilizing methods, along with special lapping techniques are some of the many critical considerations KOBA offers potential users.

All gauge blocks and accessory sets are supplied in wooden storage cases, in ingenious "easy to select" design.

The use of gauge block accessories in conjunction with gauge blocks offers the possibility of many measuring and gauging applications. KOBA accessories are manufactured to the same exacting standard as are our gauge blocks.

When KOBA is selected we are confident that our customers are obtaining the very best in materials, workmanship and, most important, value for money. Kolb & Baumann runs a DKD Laboratory accredited by the Deutscher Akkreditierungsrat .



Made in Germany

KOBA - Ceramic - Gauge Blocks made of zirkonia



wear resistant – stability in size – corrosion resistant



Advantages:

- wear resistant similar to carbide
- high hardness
- thermal expansion coefficient almost similar to steel
- corrosion resistant
- each ceramic gauge block is provided with identification number and calibration certificate
- best for use in the work shop

Technical data:

- density 6,05 g/cm³
- total porosity 0 ‰
- hardness 1350 HV
- compressive strength 2100 N/mm²
- bending strength 800 N/mm²
- modulus of elasticity 205.000 N/mm²
- thermal conductivity 2,3 W/mK
- coefficient of expansion $(10 \pm 1) \cdot 10^{-6} \text{ K}^{-1}$



Limit deviations of the length l_e at any point and tolerances of variation in length l_V to EN ISO 3650:1998, former DIN 861

nominal length range mm	calibration grade K		grade 0		grade 1		grade 2	
	limit deviations of length at any point from nominal length	tolerance for the variation in length	limit deviations of length at any point from nominal length	tolerance for the variation in length	limit deviations of length at any point from nominal length	tolerance for the variation in length	limit deviations of length at any point from nominal length	tolerance for the variation in length
	$\pm l_e$ μm	l_V μm	$\pm l_e$ μm	l_V μm	$\pm l_e$ μm	l_V μm	$\pm l_e$ μm	l_V μm
from 0,5 up to 10	0,2	0,05	0,12	0,1	0,2	0,16	0,45	0,3
over 10 up to 25	0,3	0,05	0,14	0,1	0,3	0,16	0,6	0,3
over 25 up to 50	0,4	0,06	0,2	0,1	0,4	0,18	0,8	0,3
over 50 up to 75	0,5	0,06	0,25	0,12	0,5	0,18	1	0,35
over 75 up to 100	0,6	0,07	0,3	0,12	0,6	0,2	1,2	0,35
over 100 up to 150	0,8	0,08	0,4	0,14	0,8	0,2	1,6	0,4
over 150 up to 200	1	0,09	0,5	0,16	1	0,25	2	0,4
über 200 up to 250	1,2	0,1	0,6	0,16	1,2	0,25	2,4	0,45
over 250 up to 300	1,4	0,1	0,7	0,18	1,4	0,25	2,8	0,5
over 300 up to 400	1,8	0,12	0,9	0,2	1,8	0,3	3,6	0,5
over 400 up to 500	2,2	0,14	1,1	0,25	2,2	0,35	4,4	0,6
over 500 up to 600	2,6	0,16	1,3	0,25	2,6	0,4	5,0	0,7
over 600 up to 700	3	0,18	1,5	0,3	3	0,45	6,0	0,7
over 700 up to 800	3,4	0,2	1,7	0,3	3,4	0,5	6,5	0,8
over 800 up to 900	3,8	0,2	1,9	0,35	3,8	0,5	7,5	0,9
over 900 up to 1000	4,2	0,25	2	0,4	4,2	0,6	8	2

Accuracy

KOBA Gauge Blocks are manufactured and verified to the specifications of EN ISO 3650. As tolerances are kept to a minimum by internal standards, it is guaranteed that every KOBA Gauge Block is within the limits stipulated.



△ KOBA-Laboratory (partial view)

Gauge Block Inspection ▽



The high level of accuracy and the reliability of the measuring results are guaranteed by two separate feed-backs attributed to the internationally fixed unit of length by means of a wave length,

- permanent comparison with the master gauges interferometrically verified by the Physikalisch-Technischen Bundesanstalt,
- parallel to this interferometric examination in our fully airconditioned laboratories.

Tolerance ranges of the individual grades within the limits of which the actual size is guaranteed, can be taken from the table above.

The durability of gauge blocks is achieved by a special process developed by us, combining natural and artificial ageing.

The grade of accuracy should be selected according to the intended purpose.

K: Gauge blocks of Grade K are excellently suitable as the most accurate material measure with regard to length, and for checking gauge blocks of lower grades.

Gauge blocks of Grade K will be clearly marked with a serial no. They will be supplied with a DKD-calibration certificate which shows the deviation from the nominal size of each gauge block. Please ask for our special offer.

0: Used as master gauges for all accurate measurements of length, for checking all gauge blocks in use, for final inspection, for setting accurate measuring instruments.

1: For checking of gauges, for setting measuring instruments.

2: Used as standard for setting or workshop gauge for the manufacture of jigs and gauges, as well as for machines and instruments.

Upon request we supply a certificate of true size value of the Physikalisch-Technische Bundesanstalt, which will be charged separately.

In most of the factories the use of only one grade will not do, as the accuracy varies in the individual departments and manufacturing stages. But just this fact implies the efficient use of gauge blocks. Example: If gauge blocks of grade 0 are no longer accurate enough for inspection as a result of frequent use they are passed on to a department or workshop place where the demands on the accuracy are accordingly lower.

We recommend, however, to have them inspected at our laboratory before passing on.

Material

Special Steel stable in size, wear resistant

KOBA Steel Gauge Blocks

This carefully hardened and stress relieved steel type which is specially smelted resulting in the highest possible degree of purity has a homogeneous molecular distribution which gives excellent properties against abrasion and wear. The wear is well minimized due to the homogenous dispersal of steel elements and thus uniform fine structure of carbide components. A clever method of ageing will remove residual austenite and therefore guarantee smallest possible changes in size even below the EN ISO-standard.

Ceramic

KOBA Ceramic Gauge Blocks

The wear behavior of KOBA Ceramic Gauge Blocks is similar to that of carbide. The co-efficient of thermal expansion is closer to steel and is $(10 \pm 1) \cdot 10^{-6} \text{ K}^{-1}$. Ceramic gauge blocks are not subject to corrosion and are therefore excellently suitable for the work shop. The bending strength of 800 N/mm^2 is so high that there is no danger of breakage during ordinary use. KOBA Ceramic Gauge Blocks are available in grades 0, 1 and 2.

Carbide

KOBA Carbide Gauge Blocks

The wear ratio as compared to that of steel is approx. 1:50 to 1:100. Carbide gauge blocks are mainly used as wear protectors as gauge block combination specially wears at the outside measuring faces.

All KOBA gauge block sets are provided with two empty slots for storing carbide wear protectors, in 1 mm or 2 mm.

Every gauge block from 0,5 – 100 mm is available of solid tungsten carbide. The material used in these gauge blocks has a co-efficient of thermal expansion $4,5 \cdot 10^{-6} \text{ K}^{-1}$. Carbide gauge blocks are used in workshops and tool rooms under severe wear and abrasion conditions.

We wish to stress that steel gauge blocks be used where when work pieces of steel have to be checked and a standard reference temperature of exactly 20°C cannot be maintained. Considering the difference of the co-efficient of thermal expansion between steel and carbide, this would lead to a larger uncertainty of measurement.

Single Gauge Blocks

from – up to	Graduation	Material
0,1 – 0,49	0,01	H
0,5 – 0,99	0,01	SH
0,5 – 0,95	0,05	K
1		SHK
1,0005		SHK
1,001 – 1,009	0,001	SHK
1,01 – 1,49	0,01	SHK
1,5 – 1,9	0,1	SHK
2 – 25	0,5	SHK
30		SHK
40		SHK
50		SHK
60		SHK
70		SHK
75		SHK
80		SHK
90		SHK
100		SHK

S = available in steel

H = available in carbide

K = available in ceramic

nominal size	Material
125	SKb
150	SKb
175	SKb
200	SKb
250	SKb
300	SKb
400	SKb
500	SKb
600	S
700	S
800	S
900	S
1000	S

S = available in steel

Kb = available with ceramic tips

Intermediate sizes on request

Cross section

Rectangular cross section:

below 0,5 mm	20 × 9
0,5 – 10 mm	30 × 9
over 10 mm	35 × 9

Gauge Blocks over 100 mm are manufactured with clamping holes at both ends for use with gauge block clamps, which may be used in conjunction with holders of other manufacturers.

Other cross sections on request.

Storage case

KOBA Gauge Blocks are furnished in fine wooden boxes.

Every case is provided with a serial No.



Verification by means of the interference comparator at the KOBA laboratory.



1087 M



1111 M

Gauge Block Sets, metric

Smallest Step mm	Number of Gauge Blocks	Contents dimensions in mm	pcs.	Standard measuring range	Weight kg	Set No. Order No.
0,0005	122	1,0005	1	3-270	4,2	1122 M ...4001122
		1,001 1,002 1,003 . . . 1,009	9			
		1,01 1,02 1,03 . . . 1,49	49			
		0,5 1 1,5 1,6 1,7 1,8 1,9	7			
		2 2,5 3 . . . 25	47			
30 40 50 60 70	5					
75 80 90 100	4					
0,001	116	1,001 1,002 1,003 . . . 1,009	9	2-270	4,0	1116 M ...4001116
		1,01 1,02 1,03 . . . 1,49	49			
		0,5 1 1,5 2 . . . 25	50			
		30 40 50 60 . . . 100	8			
0,001	111	1,001 1,002 1,003 . . . 1,009	9	2-225	3,8	1111 M ...4001111
		1,01 1,02 1,03 . . . 1,49	49			
		0,5 1 1,5 2 . . . 24,5	49			
		25 50 75 100	4			
0,0005	112	Supplement to 1111 M plus size 1,0005 (1111 M + 1,0005 mm)		3-225	3,8	1112 M ...4001112
0,005	103	1,005	1	2-225	3,8	1103 M ...4001103
		1,01 1,02 1,03 . . . 1,49	49			
		0,5 1 1,5 2 . . . 24,5	49			
		25 50 75 100	4			
0,001	91	1,001 1,002 1,003 . . . 1,009	9	2-270	3,1	1091 M ...4001091
		1,01 1,02 1,03 . . . 1,49	49			
		1,6 1,7 1,8 1,9	4			
		0,5 1 1,5 2 . . . 9,5	19			
		10 20 30 . . . 100	10			
0,001	87	1,001 1,002 1,003 . . . 1,009	9	2-270	3,0	1087 M ...4001087
		1,01 1,02 1,03 . . . 1,49	49			
		0,5 1 1,5 2 . . . 9,5	19			
		10 20 30 . . . 100	10			
0,0005	88	Supplement to 1087 M plus size 1,0005 (1087 M + 1,0005 mm)		3-270	3,0	1088 M ...4001088
0,005	83	1,005	1	2-270	3,0	1083 M ...4001083
		1,01 1,02 1,03 . . . 1,49	49			
		1,6 1,7 1,8 1,9	4			
		0,5 1 1,5 2 . . . 9,5	19			
		10 20 30 . . . 100	10			
0,005	79	1,005	1	2-270	3,0	1079 M ...4001079
		1,01 1,02 1,03 . . . 1,49	49			
		0,5 1 1,5 2 . . . 9,5	19			
		10 20 30 . . . 100	10			
0,005	76	1,005	1	2-225	2,5	1076 M ...4001076
		1,01 1,02 1,03 . . . 1,49	49			
		0,5 1 1,5 2 . . . 9,5	19			
		10 20 30 40 50	5			
		75 100	2			
0,005	47	1,005	1	3-225	2,6	1047 Ma ...4011047
		1,01 1,02 1,03 . . . 1,09	9			
		1,1 1,2 1,3 . . . 1,9	9			
		1 2 3 . . . 24	24			
		25 50 75 100	4			
0,005	47	1,005	1	3-270	2,6	1047 Mb ...4021047
		1,01 1,02 1,03 . . . 1,19	19			
		1,2 1,3 1,4 . . . 1,9	8			
		1 2 3 . . . 9	9			
		10 20 30 . . . 100	10			



The first three number of the Order No. compose as follows:

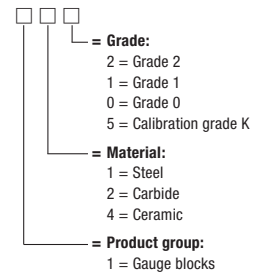

Next is the seven digit order code.

Example:

Gauge block set 103 pcs; Set No. 1103 M;

Material: steel; Grade 0 = Order No. 110 4001103



Made in Germany

- Each Gauge Block set (except for the supplementary sets) are provided with additional slots for storage of 2 carbide wear protectors 1 mm or 2 mm.
- The insert of the storage case is screwed and can be removed for cleaning.
- Bottom and cover of the storage cases contain a layer of special paper for rust prevention.
- Figure strips inside the storage cases are in oblique position for easy reading when sitting.



1047 Ma



1008 M

Gauge Block sets, metric and supplementary sets



The first three number of the Order No. compose as follows:

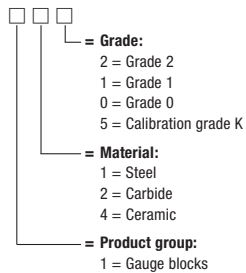

Next is the seven digit order code.

Example:

Gauge block set 32 pcs; Set No. 1032 M;

Material: steel; Grade 2 = Order No. 112 4001032



Made in Germany

Smallest Step mm	Number of Gauge Blocks	Contents dimensions in mm	pcs.	Standard measuring range	Weight kg	Set No. Order No.
0,001	46	1,001 1,002 1,003 . . . 1,009 1,01 1,02 1,03 . . . 1,09 1,1 1,2 1,3 . . . 1,9 1 2 3 . . . 9 10 20 30 . . . 100	9 9 9 9 10	3-270	2,6	1046 M ...4001046
0,001	41	1,001 1,002 1,003 . . . 1,009 1,01 1,02 1,03 . . . 1,09 1,1 1,2 1,3 . . . 1,9 1 2 3 . . . 9 10 20 40 70 100	9 9 9 9 5	3-210	2,0	1041 M ...4001041
0,005	38	1,005 1,01 1,02 1,03 . . . 1,09 1,1 1,2 1,3 . . . 1,9 1 2 3 . . . 9 10 20 30 . . . 100	1 9 9 9 10	3-270	2,5	1038 M ...4001038
0,005	33	1,005 1,01 1,02 1,03 . . . 1,09 1,1 1,2 1,3 . . . 1,9 1 2 3 . . . 9 10 20 40 70 100	1 9 9 9 5	3-210	1,6	1033 M ...4001033
0,005	32	1,005 1,01 1,02 1,03 . . . 1,09 1,1 1,2 1,3 . . . 1,9 1 2 3 . . . 9 10 20 30 50 100	1 9 9 9 4	3-100	1,2	1032 M ...4001032
0,005	18	1,005 1,01 1,02 1,03 1,06 1,1 1,2 1,3 1,6 1 2 3 6 10 20 30 60 100	1 4 4 4 5	5-190	1,5	1018 Ma ...4011018
0,001	18	1,001 1,002 . . . 1,009 1,01 1,02 . . . 1,09	9 9	-	0,4	1018 Mb ...4021018
0,001	9	1,001 1,002 . . . 1,009	9	-	0,25	1009 Ma ...4011009

Carbide wear protectors

-	2	2; 2	2	-		1002 MaH
-	2	1; 1	2	-		1002 MbH

length bars

-	8	125 150 175 200 250 300 400 500	4 1 3	-	7	1008 M ...4001008
100	9	200 300 400 500 600 700 800 900 1000	5 4	-	18	1009 Mb ...4021009
100	5	600 700 800 900 1000	5	-	4	1005 M ...4001005
-	6	50 100 200 300 400 500	6	-	5	1006 M ...4001006

- Each Gauge Block set (except for the supplementary sets) are provided with additional slots for storage of 2 carbide wear protectors 1 mm or 2 mm.
- The insert of the storage case is screwed and can be removed for cleaning.
- Bottom and cover of the storage cases contain a layer of special paper for rust prevention.
- Figure strips inside the storage cases are in oblique position for easy reading when sitting.



1010 MP



1004 MR

Gauge Block Sets for the inspection of measuring tools (DIN/ISO 9000ff)

Smallest Step mm	Number of Gauge Blocks	Contents dimensions in mm	Standard measuring range	Weight kg	Set No. Order No.	
Check sets for micrometer calipers (see page 12 for clamping stand)						
–	10	for 0–25 2,5 5,1 7,7 10,3 12,9 15 17,6 20,2 22,8 25	0–25	1,0	1010 M ...4001010	
–	10	2,5 5,1 7,7 10,3 12,9 15 17,6 20,2 22,8 25 plus 1 optical parallel Ø 30 mm	0–25	1,2	1010 MP ...4301010	
–	11	for 25–50 25 27,5 30,1 32,7 35,3 37,9 40 42,6 45,2 47,8 50	25–50	1,8	1011 Ma* ...4011011	
–	11	for 50–75 50 52,5 55,1 57,7 60,3 62,9 65 67,6 70,2 72,8 75	50–75	2,6	1011 Mb* ...4021011	
–	11	for 75–100 75 77,5 80,1 82,7 85,3 87,9 90 92,6 95,2 97,8 100	75–100	3,5	1011 Mc* ...4031011	
–	13	for 0–100 Supplement to 1010 M plus sizes 50 75 100	0–100	1,5	1013 M ...4001013	
Check sets for vernier calipers						
–	2	for 0–150 41,3 131,4	0–150	1,0	1002 M ...4001002	
–	2	for 0–150 41,3 131,4 plus 1 ring gauge Ø 30 mm	0–150	1,1	1002 MR ...4201002	
–	3	for 0–200 and 0–250 41,3 131,4 243,5	0–200 0–250	1,5	1003 M ...4001003	
–	4	for 0–200, 0–250 and 0–300 41,3 131,4 243,5 281,2	0–200 0–250 0–300	2,3	1004 M ...4001004	
–	4	for 0–200, 0–250 and 0–300 41,3 131,4 243,5 281,2 plus 1 ring gauge Ø 30 mm	0–200 0–250 0–300	2,5	1004 MR ...4201004	
–	5	41,3 131,4 243,5 281,2 481,1	up to 500	4,0	1005 Mb ...4021005	
–	7	41,3 131,4 243,5 281,2 481,1 700 900	up to 1000	9,0	1007 M ...4001007	
The gauge blocks mentioned are also available individually or as sets with different compositions. The nominal sizes stated are in accordance with guideline VDI/VDE/DGQ 2618.						
Combination set for micrometer calipers 0–25 and vernier calipers 0–150						
<i>new</i>	12	for 0–25 2,5 5,1 7,7 10,3 12,9 15 17,6 20,2 22,8 25 plus 1 optical parallel Ø 30 and 1 ring gauge Ø 30 mm	for 0–150 41,3 131,4	0–25 and 0–150	2,0	1012 MPR ...4401012
–	12	same as 1012 MPR but without optical parallel and ring gauge			1,8	1012 M ...4001012



The first three number of the Order No. compose as follows:

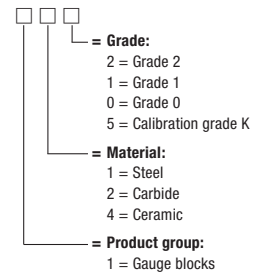

Next is the seven digit order code.

Example:

Gauge block set 11 pcs; Set No. 1011 Ma;

Material: steel; Grade 1 = Order No. 111 4011011



Made in Germany

* available Grade 1 and 2 only

- The insert of the storage case is screwed and can be removed for cleaning.
- Bottom and cover of the storage cases contain a layer of special paper for rust prevention.
- Figure strips inside the storage cases are in oblique position for easy reading when sitting.

Monitoring and calibration of inspection equipment by use of gauge blocks



Relevant quality management standards such as EN ISO 9001:2000, TS 16949 etc. demand a comprehensive and regular calibration of the measuring instruments used by the company.

The VDI/VDE/DGQ-guidelines 2618 and calibration guidelines DKD-R 4.3 of the German Calibration Service which have been accepted in many sectors form the basis for the execution of calibration of length measurement equipment.

The DKD-R 4.3 describes the required scopes of calibration under metrological aspects, presents possible measuring procedures and mentions suitable standards for the execution of a calibration of inspection equipments. The calibration procedures documented in DKD-R 4.3 are the working basis for each of the DKD-laboratories accredited for the calibration of inspection equipment.

The wide-spread VDI/VDE/DGQ guideline 2618 is “the” manual for the practical execution of the appropriate monitoring and measuring tasks in line with the monitoring of inspection equipment. It serves as a working basis for many companies certified to EN ISO 9000:2000 or TS 16949. For the majority of respectable servicing companies within the sector of inspection equipment calibration the VDI/VDE/DGQ guideline 2618 is also the basis for the applied test sequences.

As can be seen from the following listing the numbering of the two guideline families is identical. This is the consequence of constructional co-operation of both organizations and a distribution of tasks according to the respective strengths. Thus the DKD is responsible for metrologically sensible calibration procedures whereas VDI/VDE/DGQ represents practice-oriented implementation of the calibration procedures.

Frequently in guidelines for the execution of incoming or monitoring inspections but also for the calibration of measurement equipment the use of gauge blocks is recommended or even compulsory. On one hand this reflects the large confidence into the metrological characteristics of the gauge block, but also proves how practical and effective gauge blocks can be applied in this segment.

Measuring and inspection equipments for which inspection/calibration by gauge blocks is recommended:

Measuring and inspection equipment	DKD-R 4.3	VDI/VDE/DGQ-guideline
Gauge Blocks	Sheet 3.1	Sheet 3.1
Snap gauges	Sheet 4.7	Sheet 4.7
Vernier calipers	Sheet 9.1	Sheet 9.1
depth vernier calipers	n. a.	Sheet 9.2
height calipers	n. a.	Sheet 9.3
Micrometer calipers	Sheet 10.1	Sheet 10.1
Micrometer calipers for thread measurements	Sheet 10.2	n. a.
Dial test indicators	Sheet 10.3	Sheet 10.3
Lever calipers for outside measurements	n. a.	Sheet 12.1
Further guidelines under preparation		

Calibration master for checking vernier calipers and height gauges

Gauge blocks in ceramic

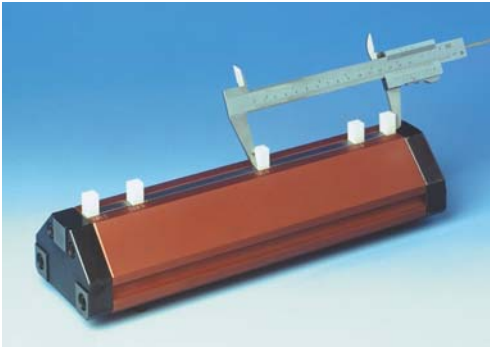

For measuring range up to 300 mm.

Steps according to VDI/VDE/DGQ 2618
41,3/131,4/243,5/281,2 mm.

For horizontal and vertical application.

Set No. 1004 Ma (5,2 kg/with box 9,3 kg)
Order No. 5410011004

For measuring range up to 500 mm.

Steps according to VDI/VDE/DGQ 2618
41,3/131,4/243,5/281,2/481,1 mm.

For horizontal and vertical application.

Set No. 1005 Ma (7,6 kg/with box 10,9 kg)
Order No. 5410011005

For measuring range up to 1000 mm.

Steps according to VDI/VDE/DGQ 2618
41,3/131,4/243,5/281,2/481,1/700/900 mm.

For horizontal and vertical application.

Set No. 1007 Ma (12,8 kg/with box 20,5 kg)
Order No. 5410011007

Other spacings available on request.



Clamping stand No. 2350



Measuring range 0–100 mm,

in combination with check sets 1010 M /
1010 MP / 1011 Ma / 1011 Mb / 1011 Mc.

Simple and efficient handling while
temperature of the hand will be avoided.

Set No. 2350
Order No. 2160002350



Check set for depth gauges



Composition same as Set No. 1010 M
Set No. 1010 MT / Order No. 5324401010

Composition same as Set No. 1011 Ma
Set No. 1011 MaT / Order No. 5324411011

Composition same as Set No. 1011 Mb
Set No. 1011 MbT / Order No. 5324421011

Composition same as Set No. 1011 Mc
Set No. 1011 McT / Order No. 5324431011

Other steps on request.



11 piece	0,5	0,5	1,0	1,005	1,01	1,0 kg	Set No. 1011 M Order No. 1154001011
	4,0	4,0	100	100 mm	6 (bridge type)		

Uncertainties of measurement:
PTB U = 0,01 µm / KOBA U = 0,03 µm

The required calibration of set 1011 M can either be carried through by the Physikalisch-Technische Bundesanstalt or by our DKD-laboratory.

Guideline for the calibration of gauge block comparators within the framework of the German Calibration Service (DKD) - DKD - R 4-1 - Edition 1994

in accordance with the European cooperation for Accreditation of Laboratories **EA - G21** August 1996

1 Range of application

This guideline is applicable to gauge block measuring instruments used to calibrate gauge blocks up to 100 mm nominal length by the differential measuring method (of. DIN 861, part 1, January 1980, section 6.3). Accredited calibrating DKD laboratories follow this guideline taking the conditions stipulated upon accreditation into account.

The terms used in this guideline are in compliance with DIN 861, part 1, DIN 1319 and DIN 2257.

2 Components of the gauge block measuring instrument

The gauge block measuring instrument comprises the measurement pedestal, the measurement table with gauge block positioning device, two length indicators, an electronic measuring instrument with numerical display and digital interface, if necessary.

3 Carrying-out of the calibration

3.1 External inspection

The following characteristics of state shall be checked:

- perfect condition of the upper surface of the measurement table;
- undamaged condition and sphericity of the measuring faces of the anvils and central position of the vertex of the measuring faces;
- measuring force of the upper and lower length indicators in compliance with the manufacturer's specifications;
- correct sequence for the retraction of the two anvils. The measuring face of the lower anvil must be retracted under the surface of the measurement table.
- in the non-lowered position, the measuring face of the lower anvil shall protrude from the measurement table surface by 20 µm to 100 µm.

3.2 Standards used

The pairs of gauge blocks No. 1 to No. 6 made of the same material are considered to be standards. The pairs to be used together during calibration have been marked by A and B and provided with an identification number. As regards the quality of the measuring faces, the standards shall be of the calibration degree K, with the exception of the special gauge block. Gauge block B of pair No. 6 is a special block designed as a bridge; one of its measuring faces is divided into three sections of almost equal size (9 x 10 mm), the two outer sections being 13 ± 3) µm higher than the center section. The plane measuring face of the gauge block must have wringing quality. The deviation should not exceed 0,05 µm in the central area (7 mm in diameter) and 0,2 µm on the protruding sections.

Pair No.	Nominal dimensions	
	A (mm)	B (mm)
1	0,5	0,5
2	1,0	1,005
3		1,01
4	4,0	4,0
5	100,0	100,0
6	6,0	6,0*

* bridge type

The difference between the central lengths of gauge blocks A and B forming pairs 1 to 5, and the deviations f_0 and f_U from the central length of gauge blocks B of pairs 2 and 3 have been determined with an uncertainty of measurement of 0,015 µm. Gauge block pair No. 6 has not been calibrated.

3.3 Calibration method

3.3.1 Differential measurement of the central lengths

Using the standards, 5 differential measurements with each of the gauge block pairs Nos. 1 to 5 shall be carried out on the gauge block measuring instrument to be calibrated. The 5 measurements shall be repeated after the positions of gauge blocks A and B have been interchanged in the gauge block positioning device.

3.3.2 Differential measurement with the special gauge block

Two measurement series, each comprising 10 measurements, shall be carried out for pair No. 6. In the first measurement series, the special gauge block shall be arranged so that the plane measuring face touches the measuring table; the bridge-like measuring face shall touch the table during the second measurement series. These measurements allow the sensitivity of the lower length indicator to be checked as well.

3.3.3 Deviations f_0 and f_U from the central length

To determine the deviations f_0 and f_U , each of the four points defined in DIN 861, section 6.3.2, and located in the four edges of the measuring face of the single gauge block 1,005 mm or 1,01 mm shall be traced 5 times in succession (of. drawing) starting in the center of the measuring face.

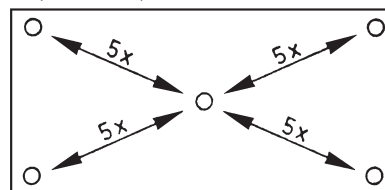

The four measurement series shall be repeated after the gauge block has been rotated through 180° with the position of the contact area remaining unchanged.

4 Evaluation of the measurement results and information to be given in the calibration certificate

4.1 Difference between central lengths

From the single values determined according to 3.3.1, the mean value (arithmetic mean) and the standard deviation (DIN 2257, section 4.1.3) shall be determined for each measurement series of a pair of gauge blocks (10 measurement values).

4.2 Difference between the central lengths of gauge block pair No. 6

From the single values determined according to 3.3.2, the mean values, the difference between the mean values and the standard deviations shall be determined for the two measurement series (10 measurement values each) corresponding to the two positions of the special gauge block.

4.3 Deviations f_0 and f_U from the central length

From the single values determined according to 3.3.3, the mean value and the standard deviation shall be determined for each measurement series.

The deviations f_0 and f_U from the central length result from the eight mean values.

4.4 Assessment criteria

All standard deviations determined according 4.1, 4.2 und 4.3 must not exceed the value of 0,015 µm. The permissible deviation of the mean values according to 4.1, and the permissible deviation of the values f_0 and f_U according to 4.3 from the values of the standards amount to ± 0,03 µm. The difference between the mean values according to 4.2 may be ± 0,03 µm at most.

4.5 Place of calibration

The gauge block measuring instrument shall be calibrated at its place of use.

4.6 Information to be given in the calibration certificate

The following minimum information must be given in the calibration certificate:

- 4.6.1 The place of use.
- 4.6.2 The calibration number and identification number of the standards used.
- 4.6.3 The manufacturer, type designation and serial number of the components of the gauge block measuring instrument.
- 4.6.4 The principle of the length indicators.
- 4.6.5 Measuring range used and digital step of the display during calibration.
- 4.6.6 Setting of the control elements of the electronic length measuring instrument (compound circuit).
- 4.6.7 Temperature range in which the calibration was carried out.
- 4.6.8 Measurement results in tabular form: The "differences between the central lengths" E according to 4.1 and the values N of the standards at 20°C shall be compared and the difference E-N and the standard deviation according to 4.1 indicated. For gauge block pair No. 6, the mean values of the two measurement series according to 4.2, the difference between the mean values, and both standard deviations shall be stated. The "deviations f_0 and f_U from the central length" E determined according to 4.3 with the gauge block measuring instrument shall be compared with the values N of the standard, and the difference and the maximum standard deviation of the 8 measurement series concerned shall be stated.
- 4.6.9 If the instrument meets the requirements according to 4.4, both the measurement pedestal and the display unit of the gauge block measuring instrument shall be provided with a DKD calibration mark.



DKD
K-01301

German Calibration
Service DKD
for length measurements
up to 1000 mm

Since 1979 Kolb & Baumann operates a calibration laboratory of the German Calibration Service – DKD – for length measurements, accredited by the Physikalisch-Technische Bundesanstalt – PTB.

Aims and tasks of the German Calibration Service

The DKD was established on 25th August 1977 by the Federal Ministry of Economics, the Physikalisch-Technische Bundesanstalt (PTB) as the highest technical authority for metrology in the Federal Republic of Germany, and the industry. The DKD guarantees that measuring and testing equipment of industrial metrology is linked to national standards. In industry there is a need for high precision measuring instruments and measuring standards to be calibrated, and awarded a recognized test certificate. This promotes competition on the national and international markets.

The importance of the DKD

In public commissioning, in export and in technological and scientific collaboration, proof of the conformity with national standards is increasingly required for the measuring equipment used for product testing. To guarantee the reliability of measuring results, for example, testing regulations of national and other official bodies often include the requirement that the measuring equipment used must have been calibrated against national standards.

The importance of calibration certificates on the national and international competition is increasing more and more. Therefore it is of interest both for the manufacturer and the user of the measuring equipment.

With this, the gauge block has a particular importance as it represents the standard of length.

The issue of DKD-calibration certificates raises the confidence in the metrological qualification of the calibration center. This is due to the fact of supervision by the PTB as the metrological national institute of the Federal Republic of Germany.



Performance

On commission, Calibration Laboratories of the DKD check measuring instruments and inspection equipment. The results are stated in a calibration certificate and the test pieces are provided with a calibration label. By this means the traceability to the National Standard is proved.

The volume of calibration is based on the DKD-guideline DKD-R4-3, as well as annexures 8 and 9 of the accreditation document.

Objekt of calibration	Uncertainty of measurement \geq
Gauge blocks / steel 0,5 thru 1000 mm	center: $0,05 \mu\text{m} + 0,5 \cdot 10^{-6} \cdot L$ f_o / f_u : $0,05 \mu\text{m}$
Gauge blocks / ceramic / tungsten carbide 0,5 thru 100 mm	center: $0,07 \mu\text{m} + 0,6 \cdot 10^{-6} \cdot L$ f_o / f_u : $0,05 \mu\text{m}$
Gauge block pairs according to DKD-R4-1	$0,03 \mu\text{m}$
Gauge block measuring instruments on site according to DKD-R4-1	$0,03 \mu\text{m} + 0,002 \cdot D$
Micrometer calipers for outside 0 – 300 mm > 300 – 1000 mm	$3 \mu\text{m} + 10 \cdot 10^{-6} \cdot L$ $5 \mu\text{m} + 10 \cdot 10^{-6} \cdot L$
Dial indicators, digital or analog up to 100 mm	$3 \mu\text{m} + 10 \cdot 10^{-6} \cdot L$
Dial test indicators up to 1,6 mm	$0,7 \mu\text{m}$
High precision dial indicators up to 3 mm	$0,5 \mu\text{m}$
Plug gauges up to 500 mm	$2 \mu\text{m} + 2 \cdot 10^{-6} \cdot L$
Setting ring gauges up to 250 mm	$2 \mu\text{m} + 2 \cdot 10^{-6} \cdot L$
Optical flats and opt. parallels	$0,1 \mu\text{m}$

(At present extensions are under preparation)

DEUTSCHER KALIBRIERDIENST DKD
Kalibrierlaboratorium für die Messgröße Länge
Calibration laboratory for the measurand length
Akcreditiert durch die / accredited by the
Akcreditierungsstelle des DKD bei der
PHYSIKALISCH-TECHNISCHEN BUNDESANSTALT (PTB)

KOLB & BAUMANN ASCHAFFENBURG

Kalibrierschein
Calibration Certificate

Kalibrierzeichen
Calibration mark

1234
DKD-K-01301
03-12

Gegenstand / Object: 122 gauge blocks to DIN EN ISO 3650 of steel, from nominal size 0,5 mm up to 100,0 mm inclusive

Hersteller / Manufacturer: "KOLB" Kolb & Baumann

Typ / Type: [blank]

Fabrikat / Serien-Nr. / Serial number: 86973

Auftraggeber / Customer: SPECIMEN

Auftragsnummer / Order No.: 26759

Anzahl der Seiten des Kalibrierscheines / Number of pages of the certificate: 7

Datum der Kalibrierung / Date of calibration: 10.12.2003

Dieser Kalibrierschein dokumentiert die Rückführung auf nationale Normale zur Darstellung der Einheiten in Übereinstimmung mit dem Internationalen Einheitensystem (SI).

Der DKD ist Unterzeichner der multilateralen Übereinkommen der European co-operation for Accreditation (EA) und der International Laboratory Accreditation Cooperation (ILAC) zur gegenseitigen Anerkennung der Kalibrierscheine.

Für die Einhaltung einer angemessenen Frist zur Wiederholung der Kalibrierung ist der Benutzer verantwortlich.

This calibration certificate documents the traceability to national standards, which realize the units of measurement according to the International System of Units (SI).

The DKD is signatory to the multilateral agreements of the European co-operation for Accreditation (EA) and of the International Laboratory Accreditation Cooperation (ILAC) for the mutual recognition of calibration certificates.

The user is obliged to have the object recalibrated at appropriate intervals.

Dieser Kalibrierschein darf nur vollständig und unverändert weiterverbreitet werden. Auszüge oder Änderungen bedürfen der Genehmigung sowohl der Akcreditierungsstelle des DKD als auch des ausstellenden Kalibrierlaboratoriums. Kalibrierscheine ohne Unterschrift und Stempel haben keine Gültigkeit.
This calibration certificate may not be reproduced other than in full except with the permission of both the Accreditation Body of the DKD and the issuing laboratory. Calibration certificates without signature and seal are not valid.

Stempel / Seal: Datum / Date: 10. Dezember 2003

Leiter des Kalibrierlaboratoriums / Head of the calibration laboratory:
Bereiter / Person in charge:

KOLB & BAUMANN GMBH & CO. KG
FABRIK FÜR PRÄZISIONSMESSWERKE
D-63741 ASCHAFFENBURG - DAMLEBERSTR. 24
TELEFON (06021) 3483-0 - TELEFAX 3483-40



Calibration of gauge blocks within the scope of the German Calibration Service DKD

General

- ▶ The expert committee "Length" of the DKD have worked out and partially released the guideline DKD-R-4-3 Calibration of measuring tools for geometric measured value. The subject of these sheets is to describe the scope of calibration based on metrological requirements and through which satisfactory results can be achieved even under consideration of economical aspects.

Field of application

- ▶ The guideline DKD-R 4-3 sheet 3.1 was definitely released for gauge blocks. This sheet describes three scopes of calibration (options). The options are to be chosen according to the use of the gauge blocks as
 - **Reference Gauge Blocks (Option 5.3.1):**
These are gauge blocks used for the calibration of other gauge blocks.
 - **Gauge Blocks in use (Option 5.3.2):**
These are gauge blocks used for setting measuring instruments and for the calibration of measuring tools.
 - **Used Gauge Blocks (Option 5.3.3):**
These are gauge blocks which are mainly used in production.

Scopes of calibration according and uncertainties of measurement

- ▶ **Option 5.3.1: Full calibration**
Visual control – rework if necessary – wringing of both measuring surfaces – Determination of the deviation of the central size from the nominal size, as well as f_0 and f_u – minimum 3 measuring cycles; smallest possible uncertainty of measurement $U = 0,05 \mu\text{m} + 0,5 \cdot 10^{-6} \cdot L$ with $k = 2$, depending on test piece and length.
- ▶ **Option 5.3.2: Reduced calibration**
Visual control – rework if necessary – flatness of both measuring surfaces – Determination of the deviation of the central size from the nominal size, as well as f_0 and f_u – minimum 2 measuring cycles; smallest possible uncertainty of measurement $U = 0,08 \mu\text{m} + 0,5 \cdot 10^{-6} \cdot L$ with $k = 2$, depending on test piece and length.
- ▶ **Option 5.3.3: Minimal calibration**
Visual control – rework – Determination of the deviation of the central size from the nominal size, as well as f_0 and f_u – minimum 2 measuring cycles; smallest possible uncertainty of measurement $U = 0,1 \mu\text{m} + 0,8 \cdot 10^{-6} \cdot L$ with $k = 2$, depending on test piece and length.

A statement as to whether sent-in gauge blocks are suitable for calibration can be made only during the calibration procedure. If you failed to specify the option according to the field of application we will carry through a calibration with the smallest possible uncertainty of measurement depending on the state of the gauge blocks. A subsequent modification is not possible.

In case of any deviation from your calibration request we shall contact you by phone the soonest possible in order to avoid unnecessary costs.





Calibration Service for gauge blocks of steel, carbide and ceramic

–traceable to National Standards via our own DKD-laboratory, in accordance with DIN/ISO 9000–9004

DKD-K-01301

Everything from one source. Fast, competent, from one supplier, direct.

A consequence from the European Market is the introduction of uniform standards and guidelines for Quality Assurance. More and more companies and contractors have to comply with the EN 29000 (DIN/ISO 9000–9004). In this connection gauge blocks are thus an important connecting link for the traceability to National Standards of the length measuring practice. In order to meet the requirements of DIN/ISO 9000 it is imperative to know their actual condition and to control them constantly.

This is where the KOBA Calibration Service can help you.

Since the rate of wear on individual gauge blocks differs, depending on how much use is made of them and what they are used for, it is not possible to lay down any standard interval between checks. However, a one year interval has proved satisfactory in practice.

Calibration sequence

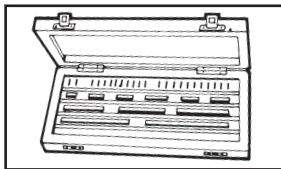

Your are sending a gauge block set for re-calibration.

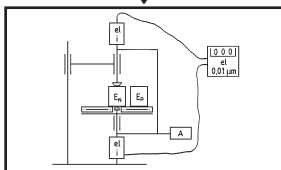

Gauge block are cleaned, de-magnetized, measuring faces are smoothed and then checked against DKD-calibrated masters by five-points-measurement.

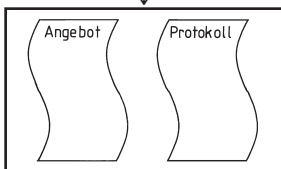

A calibration certificate with the actual findings is drawn up and sent to you together with an offer for the replacement of worn gauge blocks.



You decide, to which grade we shall replace.

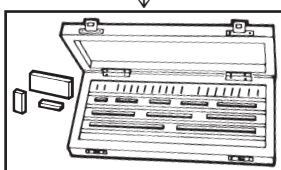

We will return the set inspected and partly replaced together with a new calibration certificate including the findings of the replaced gauge blocks and separately all the worn gauge blocks which still can be used for less important jobs.

Advantages

- The entire set is of only one grade of accuracy
- Smallest possible number of replacements
- Costs are low
- Assured standards for your quality control

When buying gauge blocks do not forget the calibration service. Without it cheap blocks may end up costing you a lot of money.

KOBA-Kalibrier-Service

Kalibrierlaboratorium für die Messgröße Länge
KOBA-Calibration-Service / Service de Contrôle KOBA



Page 2 of calibration certificate No. 12345 dated 09.12.03

Nominal size	Deviation of central length from nominal size	Deviation from central length	Tol. class	Serial No.	Rem.
mm	μm	μm			

- 0.50
- 1.0
- 1.0005
- 1.001
- 1.002
- 1.003
- 1.004
- 1.005
- 1.006
- 1.007
- 1.008
- 1.009
- 1.01
- 1.02
- 1.03
- 1.04
- 1.05
- 1.06
- 1.07
- 1.08
- 1.09
- 1.10
- 1.11
- 1.12
- 1.13
- 1.14
- 1.15
- 1.16
- 1.17
- 1.18
- 1.19
- 1.20
- 1.21
- 1.22
- 1.23
- 1.24
- 1.25
- 1.26
- 1.27
- 1.28
- 1.29
- 1.30
- 1.31
- 1.32

KOBA-Kalibrier-Service

Kalibrierlaboratorium für die Messgröße Länge
KOBA-Calibration-Service / Service de Contrôle KOBA



Calibration certificate No.: 12345

Client: Specimen

Client No.: 67890

Client Order No.: 12121

Works Order No.: B453987

Objekt of calibration: Gauge block set out of steel, 122-pieces, Tolerance class 0

Size: 0.50 - 100 mm

Manufacturer's logo: KOBA

Serial No.: various

Test procedure: Measuring of the centre deviation and the variation range by comparison against gauge blocks in accordance with DIN EN ISO 3650

Measurement standard: Measuring equipment: TRSA UPC, Serial No.: 4561; Gauge block set, Serial No.: 86137
DKD-certificate No. 1711 DKD-K-01301 01-04

Uncertainty: $U = 0,1 \mu\text{m} + 0,6 \times 10^{-6} \times l$; with $k = 2$

Result: All pieces refer to the standard

Number of pages: 2

Aschaffenburg, 09.12.03



Inspected by: Endemann
Endemann

Kob & Daumann GmbH & Co. KG
Fabrik für Präzisions-Messzeuge
Kaltbrunnensiedelstraße 24
63741 Aschaffenburg
Telefon (0821) 3483-0
Telefax (0821) 3483-40
Internet-Adresse:
http://www.koba.de
E-mail: messung@koba.de
Kalibrierlaboratorium des Deutschen Kalibrierdienstes - Heftnummer: DKD-K-01301

The testing procedure

1. The gauge blocks are cleaned and de-magnetized.
2. Scratches and burrs are removed from the gauge faces and edges. The gauge faces are dressed smooth.
3. The gauge blocks are checked by measurement by comparison against gauge blocks calibrated by the German Calibration Service (five-points-measurement).
4. A KOBA calibration certificate is drawn up, or in other words a record of the results of the measurements is produced.

If desired the measured results can be shown in detail. For this you can select one of four different types of procedures:

- P2: Grades of accuracy, centre deviations.
- P3: Grades of accuracy, centre deviations (as in P2), and variation range.
- P4: Grades of accuracy, centre deviations (as in P2), variation range (as in P3), additionally wringing of both measuring faces to an optical flat to prove wringability. Blue spots are allowed and acceptable.

Once the testing has been completed, you will receive from us a KOBA test report of the kind you opt for together with a quotation for the replacement of gauge blocks which are not suitable for continued use.

Servicing Kit

No. 1901 (0,75 kg) Order No. 2070011902



Contents:

- 1 Cloth
- 1 Chamois Leather
- 1 bottle Special Protective Oil
- 1 Deburring Stone no. 1903-1
- 1 Soft Brush
- 1 Grease Brush
- 1 set Instructions

Deburring Stone

No. 1903-1 Ord.No. 2070011903
Size 50 x 25 x 10 mm (0,05 kg)

No. 1903-2 Ord.No. 2070021903
Size 100 x 25 x 10 mm (0,1 kg)



Smallest burrs and scratches on the measuring surfaces can be remedied with the deburring stone without altering the actual size.

Optical Flat

No. 1904-1 (0,16 kg) Order No. 2880011904



Checking the flatness of measuring faces
45 mm diameter
11 mm thick
0,1 µm flatness accuracy

No. 1904-2 Order No. 2880021904
Optical parallels for checking the parallelism of measuring faces on micrometer calipers

4 pieces of 12.000 / 12.120 / 12.250 / 12.370 mm thickness – diameter 30 mm – flatness < 0,15 µm – parallelism ≤ 0,6 µm – thickness tolerance ± 0,1 mm

Gripping Plier

No. 1907 (0,18 kg) Order No. 2060001907

insulating against heat transfer of the hand and for convenient and easy handling of gauge blocks from 0.5 mm onwards.

The gripping force can be adjusted to take into account the greater weight of the large gauge blocks.



Special Protective Oil

No. 1902 (0,06 kg) Order No. 2070021902



50 ccm



Gauge Block Clamps

for gauge blocks over 100 mm

No. 1908 (0,2 kg)

Order No. 2060001908



Universal Gauge Block Holder

for individual gauge block combination over 100 mm

No. 1909

Order No. clamping range
2110011909 0–45
2110021909 0–90
2110031909 0–135
2110041909 0–180
2110051909 0–225



Clamping Stand

No. 2350 (3,7 kg)

Order No. 2160002350

Measuring range 0–100 mm, in combination with micrometer check sets 1010 M / 1010 MP / 1011 Ma / 1011 Mb / 1011 Mc.

Simple and efficient handling while temperature of the hand will be avoided.



Insulating Handles for Long Gauge Blocks

No. 1905 Ord.No. 2060001905
(0,15 kg)



No. 1906 (0,1 kg)
Ord.No. 2060001906



Gauge Block Accessories

are especially designed and manufactured to extend the high degree of gauge block accuracy into the field of fast, accurated temporary gauging, which are used in inspection departments and also in toolroom and machine shops on small batch production to keep gauging costs at a minimum.

The range of possibilities is manifold and below are quoted a number of popular examples.

- Internal cylindrical gauge
(instead of plug gauge or cylindrical limit plug gauge)
- Spacing or external gauge
(instead of snap gauge or adjustable limit snap gauge)
- Precision height gauge (instead of height marking instrument)
- Precision marking compasses
- Setting gauge for bore gauging instruments
- Master gauges for exact graduations, etc.



Examples of Gauge Block Accessories used in conjunction with Gauge Blocks

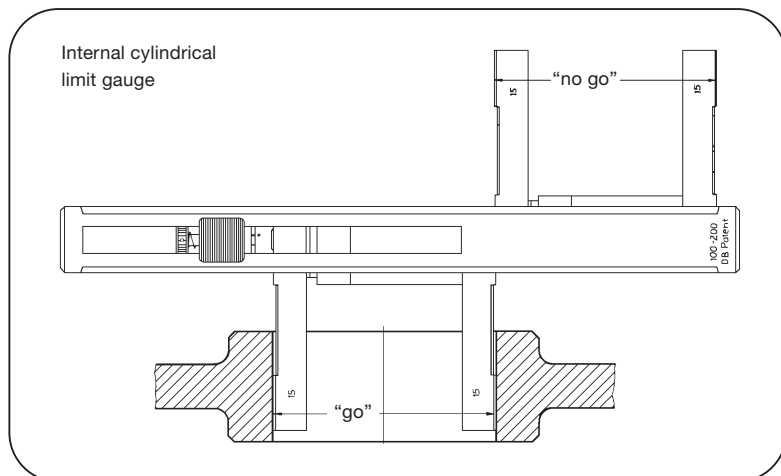
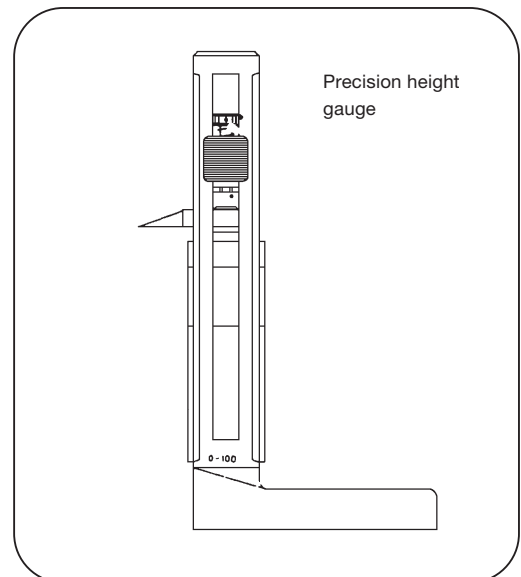
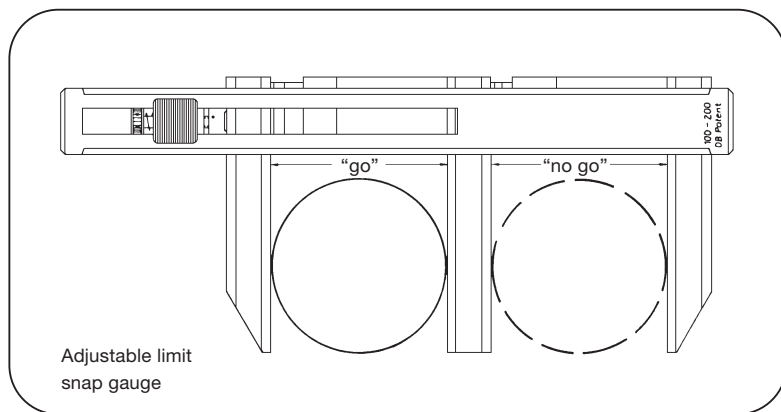
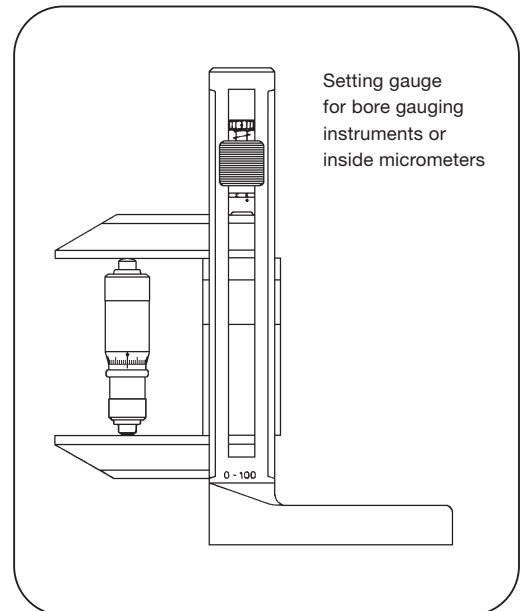
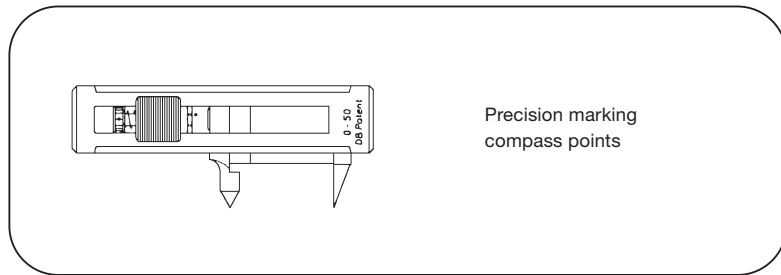

Gauge Block Holders

with quick adjustment

KOBA developed quick adjusting gauge block holders for use with precision gauge blocks, which are hand made to assure burr free side and fixing surfaces. The rack pattern positive locating groovers provide rapid adjustment and prevent gauge block combination from slipping or moving once in position, thus loading is simple, fast and safe.

The clamping slide and gauge block combination are both secured by the same thumb screw, located on the clamping slide.

On request the range of holders from 100–300 may be increased when supplied with special holes and used in conjunction with expanding block No. 2150 from 0 up. When ordering please state requirements, e.g. 0–500 mm.

Cat. No.	Measuring range mm	Weight kg
2101	0– 50	0,2
2102	0– 100	0,3
2103	0– 200	0,4
2105	100– 200	0,4
2106	100– 300	0,5
2104	0– 300	0,5
2116	200– 400	0,6
2109	300– 500	0,7
2117	400– 600	0,8
2112	500– 800	1,0
2113	800–1000	1,2
2114	1000–1200	1,4
2115	1300–1500	1,6
2118	1800–2000	1,8



Clamping elements for long gauge blocks with pin holes see page 17.

The Order No. for these products consists of:

A 6 digit basic number 211000 and next to it is the 4 digit Cat. No.

Example: Gauge block holder 0–100 mm = 2110002102

Measuring Jaws

with cylindrical shoulder for inside and outside measurements



Made in Germany

Nominal sizes (dia. of shoulder of 1 pair of jaws)	Maximum gauge depth mm	Cat. No.	Weight kg ea. pair
4 mm	8	2204	0,03
10 mm	15	2210	0,05
16 mm	20	2216	0,07
20 mm	40	2220	0,10
30 mm	65	2230	0,20
40 mm	95	2240	0,35

The Order No. for these products consists of:

A 6 digit basic number 212000 and next to it is the 4 digit Cat. No.

Example: Measuring jaws 20 mm = 2120002220

The permissible deviation of the nominal diameter is equal to the double of the permissible center deviation of a gauge block of the same nominal size in Grade 2.



Control Points



Weight ea.
pair: 0.05 kg

Cat. No. 2330 / Order No. 2130002330
For checking of graduations and of exact distances between points and lines.

Scriber Point



Cat. No. 2322 / Order No. 2130002322

For forming an accurate height gauge:
scriber point, gauge block holder, base,
gauge blocks.

Centre Point



Weight: 0.03 kg

Cat. No. 2321 / Order No. 2130002322
For forming marking compasses: centre
point, scriber point, gauge block holder,
gauge blocks.

Plane Jaws



for outside
measurements only

Cat. No.	Height abt. mm	Width mm	Length mm	Weight each pair kg
2301	20	9	100	0,18
2302	20	9	125	0,23

Suitable for forming snap gauges or adjustable limit snap gauges

Plane Parallel Jaws



for inside and outside
measurements
(not for internal diameter)

Cat. No.	Height (Grade 2) mm	Width mm	Length mm	Weight each pair kg
2304	20	9	100	0,20
2305	20	9	125	0,24

Knife Edge Jaws

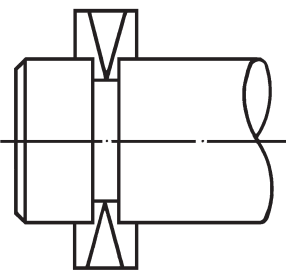

Cat. No.	Max. measurable diameter mm	Length overall mm	Weight each pair abt. kg
2310	26	55	0,07

The Order No. for these products consists of:
A 6 digit basic number 212000 and next to it is the
4 digit Cat. No.

Example: Plane jaws 100 mm = 2120002301



Base

Cat. No. 2340 Order No. 2160002340 Weight: 0,92 kg

The base is used in conjunction with gauge block holders 2101–2113.
The desired size combination being built into the gauge block holder
after which the holder is secured vertically upon the base by a holding
screw.

Sets of Accessories for Gauge Blocks

Not illustrated

Set No. 2004 M		mm	Cat. No.
1 pair	of measuring jaws	in all 40	2240
1	Gauge block holder	0-300	2104
1	Gauge block holder	300-500	2109
Weight incl. case abt. 2,5 kg		Ord. No. 2150002004	



Set No. 2010 M



Made in Germany

Not illustrated

Set No. 2010 M		mm	Cat. No.
1 pair	of measuring jaws	in all 4	2204
1 pair	of measuring jaws	in all 10	2210
1	scriber point	-	2322
1	centre point	-	2321
1	base	-	2340
1	Gauge block holder	0- 50	2101
1	Gauge block holder	0-100	2102
1	Gauge block holder	100-200	2105
Weight incl. case abt. 3 kg		Ord. No. 2150002010	

Set No. 2014 M		mm	Cat. No.
1 pair	of measuring jaws	in all 4	2204
1 pair	of measuring jaws	in all 10	2210
1 pair	of measuring jaws	in all 16	2216
1 pair	of measuring jaws	in all 20	2220
1	scriber point	-	2322
1	centre point	-	2321
1	base	-	2340
1	Gauge block holder	0- 50	2101
1	Gauge block holder	0-100	2102
1	Gauge block holder	100-200	2105
Weight incl. case abt. 3,2 kg		Ord. No. 2150002014	



Set No. 2023 M

Set No. 2023 M		mm	Cat. No.
1 pair	of measuring jaws	in all 4	2204
1 pair	of measuring jaws	in all 10	2210
1 pair	of measuring jaws	in all 16	2216
1 pair	of measuring jaws	in all 20	2220
1 pair	of measuring jaws	in all 30	2230
1 pair	of measuring jaws	in all 40	2240
1 pair	of plain parallel jaws	100	2304
1 pair	of knife edge jaws	26	2310
1	scriber point	-	2322
1	centre point	-	2321
1	base	-	2340
1	Gauge block holder	0- 50	2101
1	Gauge block holder	0-100	2102
1	Gauge block holder	100-200	2105
1	Gauge block holder	200-400	2116
Weight incl. case abt. 5 kg		Ord. No. 2150002023	

Gauge Block Accessory Sets for adjusting Internal Precision Instruments and Bore Gauges



Made in Germany

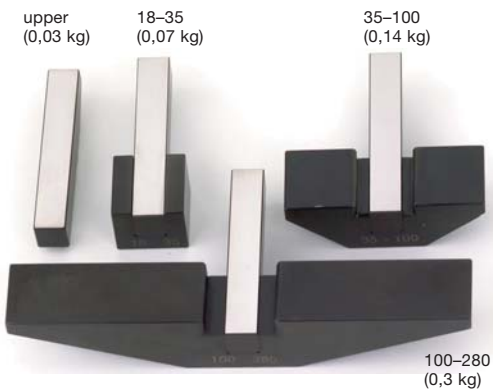

Designation	Measuring Range	Cat. No. Ord. No.
upper measuring jaws	all	2521 2120002521
lower measuring jaws	18- 35	2522 2120002522
lower measuring jaws	35-100	2523 2120002523
lower measuring jaws	100-280	2524 2120002524
lower measuring jaws *	280-510	2525 2120002525

* not illustrated

Set No. Ord. No.	Contents	Measuring Range
2505-1 2150012505	1 upper measuring jaw 1 lower measuring jaw 18- 35 1 lower measuring jaw 35-100 1 Gauge block holder 0-100 1 base	up to 100 mm
2510 2150002510	2 upper measuring jaw 1 lower measuring jaw 18- 35 1 lower measuring jaw 35-100 1 lower measuring jaw 100-280 1 Gauge block holder 0- 50 1 Gauge block holder 0-100 1 Gauge block holder 100-200 1 Gauge block holder 100-300 1 base	up to 280 mm
2505-2 2150022505 not illustrated	1 upper measuring jaw 1 lower measuring jaw 100-280 1 lower measuring jaw 280-510 1 Gauge block holder 100-600 1 base	100 up to 510

2505-1
(2,1 kg)



2510 (4,3 kg)



Parts may be ordered at random leaving open spaces in storing cases if desired.