

A..PCLNR/L

20 - 50

95°

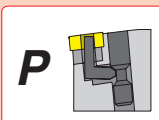
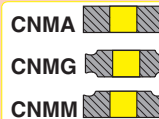
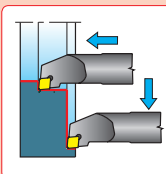
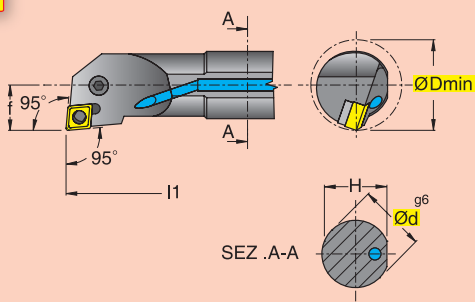

ОБОЗНАЧЕНИЕ

(mm)



Dmin d f H l1



A20Q	PCLNR/L	09	25	20	13	19	180	0903
A25R	PCLNR/L	09	32	25	17	24	200	
A20Q	PCLNR/L	09T3	25	20	13	19	180	09T3
A25R	PCLNR/L	09T3	32	25	17	24	200	
A25R	PCLNR/L	12	32	25	17	24,0	200	1204
A32S	PCLNR/L	12	40	32	22	31,0	250	
A40T	PCLNR/L	12	50	40	27	38,5	300	
A50U	PCLNR/L	12	63	50	35	48,0	350	
A40T	PCLNR/L	16	50	40	27	38,5	300	1606
A50U	PCLNR/L	16	63	50	35	48,0	350	
A50U	PCLNR/L	19	63	50	35	48,0	350	1906

A..PDUNR/L

20 - 50

93°

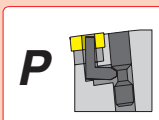
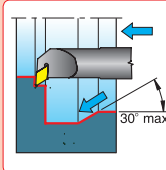
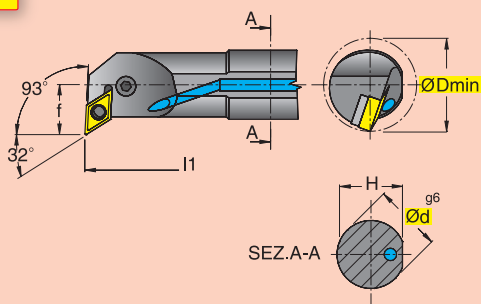

ОБОЗНАЧЕНИЕ

(mm)



Dmin d f H l1



A20Q	PDUNR/L	11	25	20	16	18,0	180	1104
A25R	PDUNR/L	11	32	25	17	23,0	200	
A32S	PDUNR/L	11	40	32	22	30,0	250	
A32S	PDUNR/L	15	40	32	22	31,0	250	1506
A40T	PDUNR/L	15	50	40	27	38,5	300	
A50U	PDUNR/L	15	63	50	35	48,0	350	
A32S	PDUNR/L	1504	40	32	22	31,0	250	1504
A40T	PDUNR/L	1504	50	40	27	38,5	300	
A50U	PDUNR/L	1504	63	50	35	48,0	350	

A..PSKNR/L

25 - 40

75°

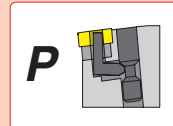
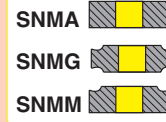
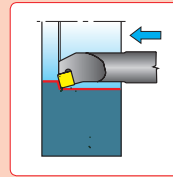
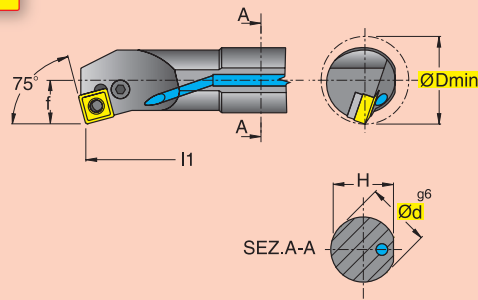

ОБОЗНАЧЕНИЕ



(mm)

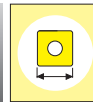

Dmin d f H l1

A25R	PSKNR/L	12	32	25	17	24,0	200
A32S	PSKNR/L	12	40	32	22	31,0	250
A40T	PSKNR/L	12	50	40	27	38,5	300

1204

A..PTFNR/L

16 - 40

90°

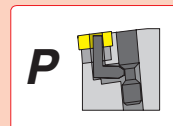
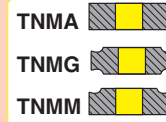
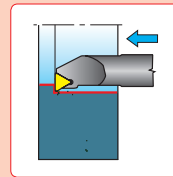
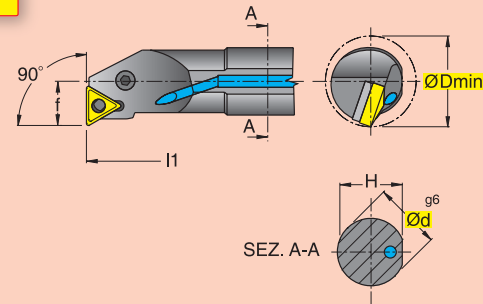

ОБОЗНАЧЕНИЕ



(mm)



Dmin d f H l1

A16M	PTFNR/L	11	21	16	11	15,25	150
A20Q	PTFNR/L	11	25	20	13	19,0	180
A25R	PTFNR/L	16	32	25	17	24,0	200
A32S	PTFNR/L	16	40	32	22	31,0	250
A40T	PTFNR/L	22	50	40	27	38,5	300

1103

1604

2204

A..PWLNR/L 16 - 40

95°

WNMA

WNMG

WNMM

P

ОБОЗНАЧЕНИЕ		(mm)						
L	R	Dmin	d	f	H	l1		
A16M	PWLNR/L 06	21	16	11	15,25	150	0604	
A20Q	PWLNR/L 06	25	20	13	19,0	180		
A25R	PWLNR/L 06	32	25	17	24,0	200		
A32S	PWLNR/L 06	40	32	22	31,0	250		
A25R	PWLNR/L 06T3	32	25	17	24,0	200		06T3
A32S	PWLNR/L 06T3	40	32	22	31,0	250		
A25R	PWLNR/L 08	32	25	17	24,0	200		0804
A32S	PWLNR/L 08	40	32	22	31,0	250		
A40T	PWLNR/L 08	50	40	27	38,5	300		

S..PCKNR/L 25 - 40

75°

CNMA

CNMG

CNMM

P

ОБОЗНАЧЕНИЕ		(mm)					
L	R	Dmin	d	f	H	l1	
S25T	PCKNR/L 12	32	25	19,5	23	300	1204
S32U	PCKNR/L 12	40	32	24	30	350	1204
S40V	PCKNR/L 12	50	40	30	38	400	1204