

A..MTFNR/L

25 - 50

90°

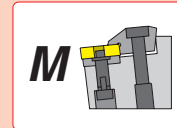
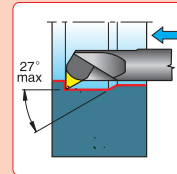
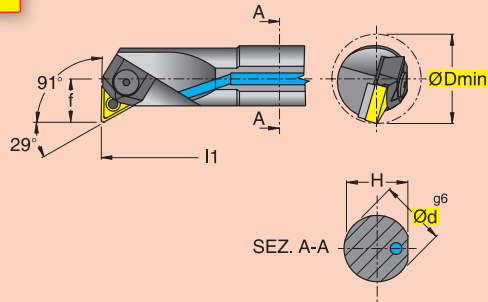

ОБОЗНАЧЕНИЕ

(mm)



Dmin d f H l1

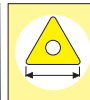

A25R	MTFNR/L	16	32	25	17	24,0	200	1604
A32S	MTFNR/L	16	40	32	22	31,0	250	
A40T	MTFNR/L	16	50	40	27	38,5	300	
A50U	MTFNR/L	16	63	50	35	48,0	350	2204
A40T	MTFNR/L	22	50	40	27	38,5	300	
A50U	MTFNR/L	22	63	50	35	48,0	350	

A..MWLNR/L..N

20 - 50

95°

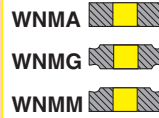
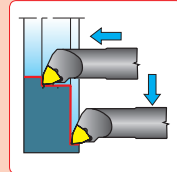
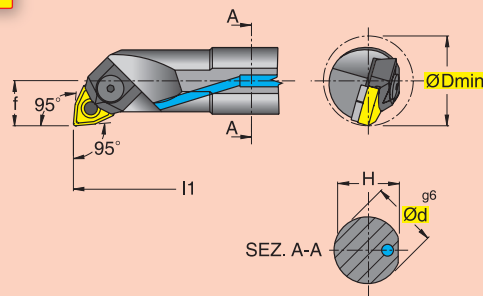

ОБОЗНАЧЕНИЕ

(mm)



Dmin d f H l1

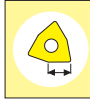

A20Q	MWLNR/L	06	25	20	13	19,0	180	0604
A25R	MWLNR/L	06	32	25	17	24,0	200	
A32S	MWLNR/L	06	40	32	22	31,0	250	
A20Q	MWLNR/L	06T3	25	20	13	19,0	180	06T3
A25R	MWLNR/L	06T3	32	25	17	24,0	200	
A32S	MWLNR/L	06T3	40	32	22	31,0	250	
A25R	MWLNR/L	08N	32	25	17	24,0	200	0804
A32S	MWLNR/L	08N	40	32	22	31,0	250	
A40T	MWLNR/L	08N	50	40	27	38,5	300	
*S50U	MWLNR/L	08N	63	50	35	47	350	0804

* Стальная оправка без отверстия для подвода СОЖ

A..MCLNR/L 25 - 50

95°

CNMA

CNMG

CNMM

M

ОБОЗНАЧЕНИЕ		(mm)						
L	R	Dmin	d	f	H	l1		
A25R	MCLNR/L	12	32	25	17	24,0	200	1204
A32S	MCLNR/L	12	40	32	22	31,0	250	
A40T	MCLNR/L	12	50	40	27	38,5	300	
A50U	MCLNR/L	12	63	50	35	48,0	350	1606
A40T	MCLNR/L	16	50	40	27	38,5	300	
A50U	MCLNR/L	16	63	50	35	48,0	350	
A50U	MCLNR/L	19	63	50	35	48,0	350	1906

A..MDUNR/L 25 - 40

93°

DNMA

DNMG

DNMM

M

ОБОЗНАЧЕНИЕ		(mm)							
L	R	Dmin	d	f	H	l1	h		
A25R	MDUNR/L	15	32	25	17	24,0	200	1,5	1506
A32S	MDUNR/L	15	40	32	22	31,0	250	0	1506
*S32U	MDUNR/L	15	40	32	22	31,0	350	0	1506
A40T	MDUNR/L	15	50	40	27	38,5	300	0	1506

* Стальная оправка без отверстия для подвода СОЖ

A..MVPNR/L

25 - 40

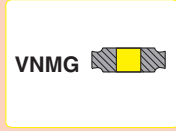
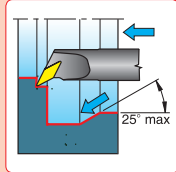
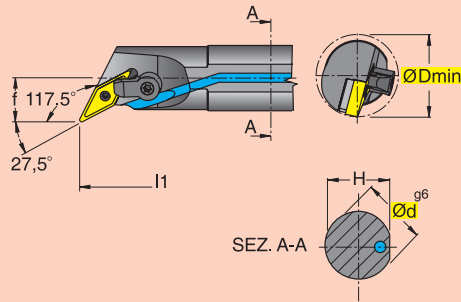

ОБОЗНАЧЕНИЕ

(mm)



Dmin d f H l1

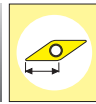

A25R	MVPNR/L	16
A32S	MVPNR/L	16
A40T	MVPNR/L	16

32	25	17	24,0	200
40	32	22	31,0	250
50	40	27	38,5	300

1604
1604
1604

A..MVUNR/L

25 - 40

93°

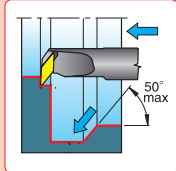
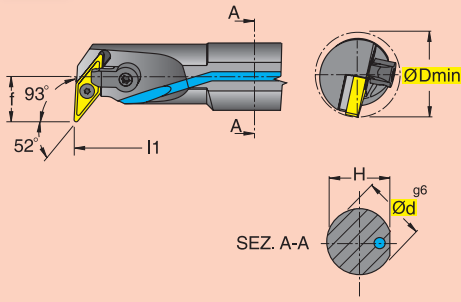

ОБОЗНАЧЕНИЕ

(mm)



Dmin d f H l1

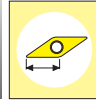

A25R	MVUNR/L	16
S25T	MVUNR/L	16
A32S	MVUNR/L	16
*S32U	MVUNR/L	16
A40T	MVUNR/L	16

32	25	17	24,0	200
38	25	25	24,0	300
40	32	22	31,0	250
40	32	22	31,0	350
50	40	27	38,5	300

1604
1604
1604
1604
1604

* Стальная оправка без отверстия для подвода СОЖ

A..MVZNR/L 32 - 40

ОБОЗНАЧЕНИЕ			(mm)						
			Dmin	d	f	H	I1		I2
A32S	MVZNR/L	16	48	32	30	31,0	250	14	1604
A40T	MVZNR/L	16	57	40	35	38,5	300	15	

MTUNR/L 25 - 32

93°

ОБОЗНАЧЕНИЕ			(mm)					
			Dmin	d	f	H	I1	
S25T	MTUNR/L	16	32	25	19,5	23	300	1604
S32U	MTUNR/L	16	40	32	24	30	350	1604

MSKNR/L

25 - 32

75°

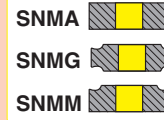
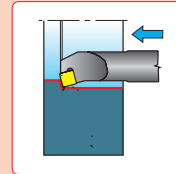
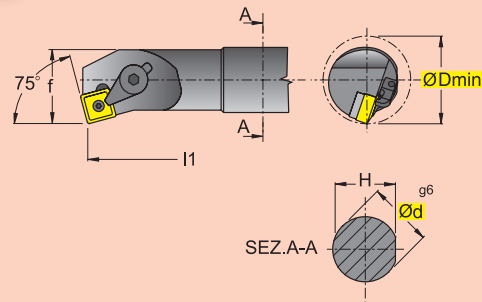

ОБОЗНАЧЕНИЕ

(mm)



Dmin d f H l1

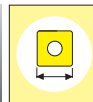

S25T	MSKNR/L	12	32	25	19,5	23	300	1204
S32U	MSKNR/L	12	40	32	24	30	350	1204

MWLNRL/L

25 - 32

95°

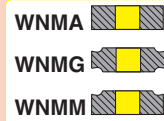
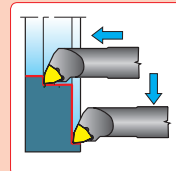
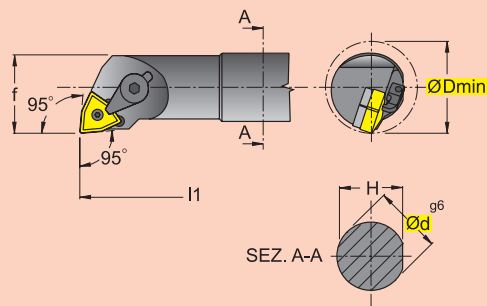

ОБОЗНАЧЕНИЕ

(mm)



Dmin d f H l1



S25T	MWLNRL/L	08	32	25	19,5	23	300	0804
S32U	MWLNRL/L	08	40	32	24	30	350	0804